

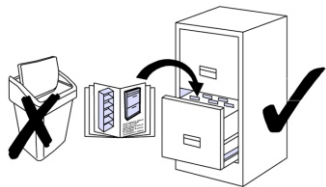

Modell: **MEGAN 180x200**

Art. Nr.: **23 000 172/01**

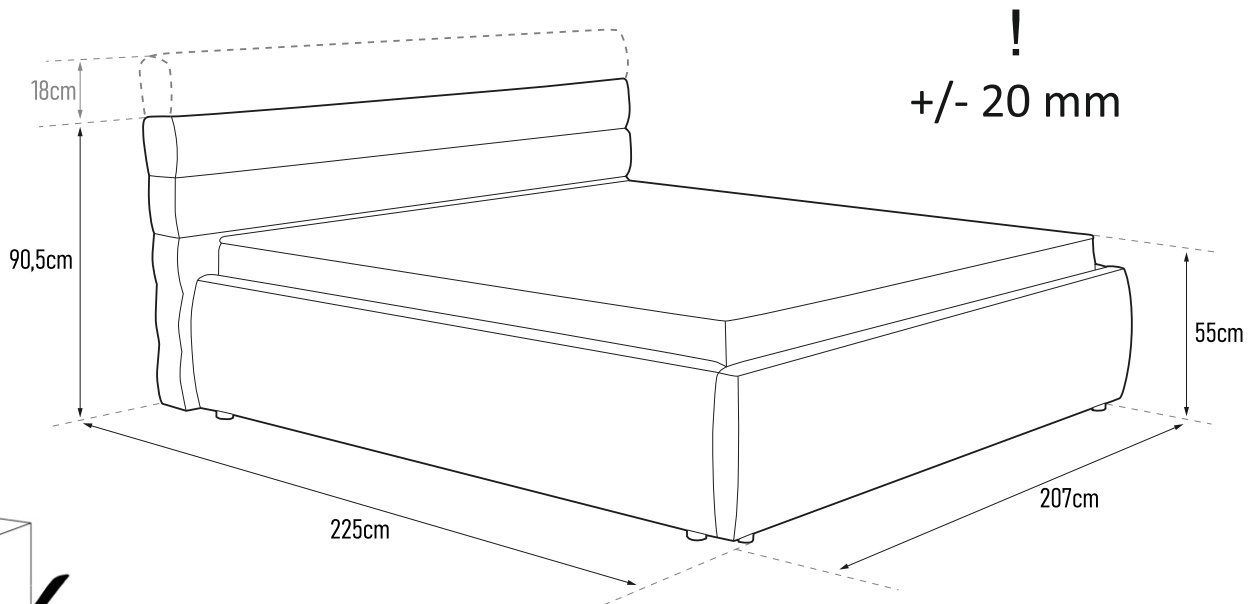
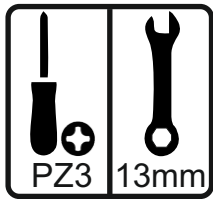

①	197	9	41	x1
②	204	9	41	x1
③	204	9	41	x1
④	203	4,5	21,5	x1
⑤	89,7	50	1,2	x2
⑥	207	15	88	x1
⑦	101	89,5	4	x4

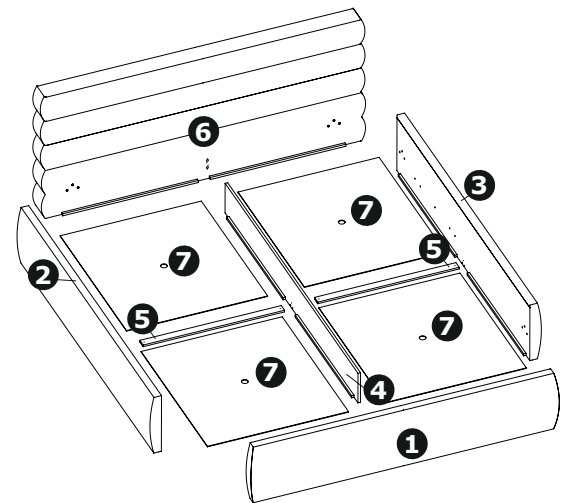

<b>A</b>  130x130x65 mm	<b>x4</b>	<b>B</b>  M8x40	<b>X24</b>	<b>C</b>  Ø50x25 mm	<b>x10</b>	<b>D</b>  Ø5x40 mm	<b>x8</b>	<b>E</b>  M8x35	<b>x4</b>	<b>F</b>  5 mm	<b>x1</b>	<b>G</b>  Ø30x3 mm	<b>x8</b>	<b>H</b>  Ø19x8 mm	<b>x10</b>
<b>J</b>  M6x30	<b>x10</b>	<b>K</b>  Ø4x16 mm	<b>X24</b>	<b>L</b>  Ø4x40 mm	<b>x10</b>	<b>M</b>  20x25x25 mm	<b>x12</b>	<b>N</b>  16x27x10 mm	<b>x12</b>	<b>P</b>  90x40x30 mm	<b>x1</b>	<b>R</b>  90x20 mm	<b>x2</b>	<b>S</b>  Ø46x5 mm	<b>x4</b>
<b>T</b>  Ø8x36 mm	<b>4x</b>	<b>U</b>  Ø8x60 mm	<b>2x</b>	<b>W</b>  90x17 mm	<b>x1</b>	<b>Y</b>  90x40x30 mm	<b>x1</b>								



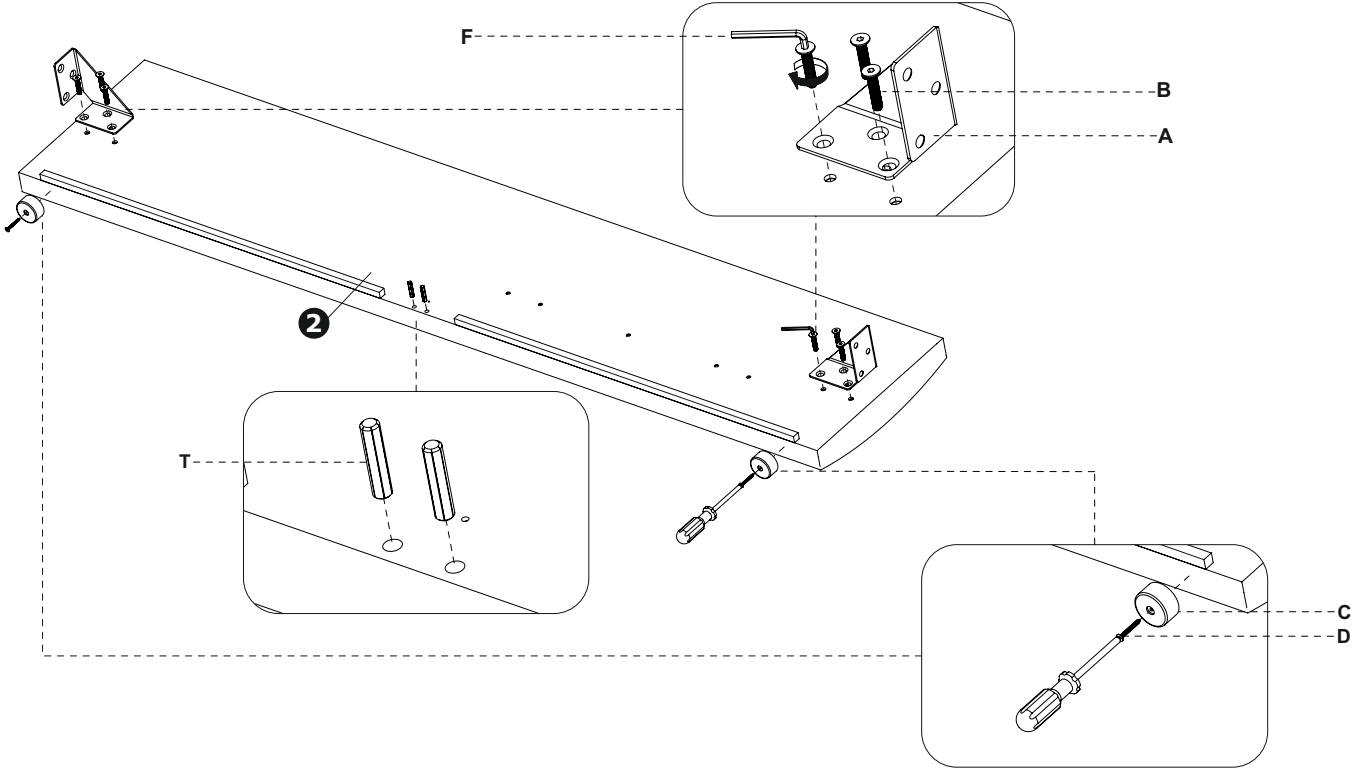

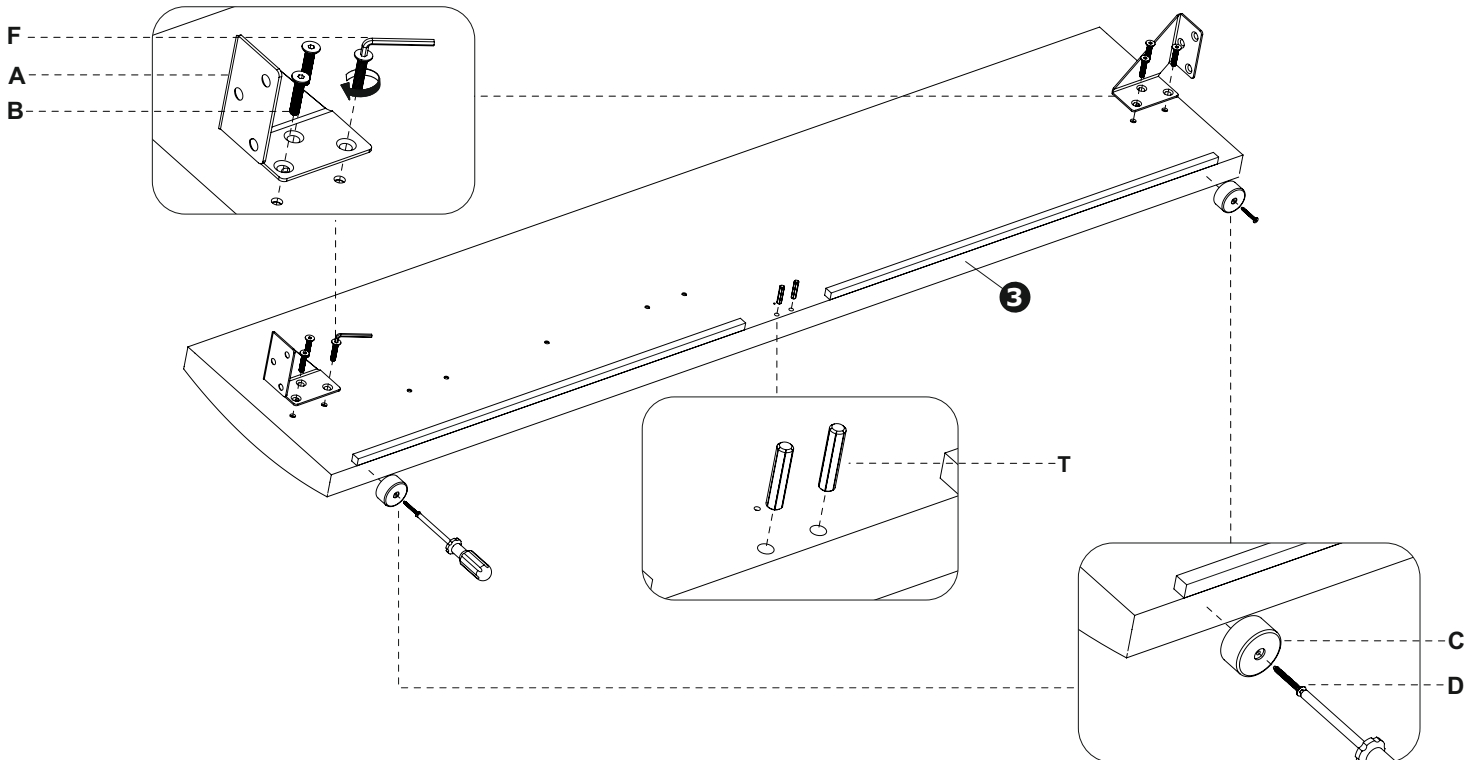

<b>1</b>	<b>A</b> x2	<b>B</b> x6	<b>C</b> x2	<b>D</b> x2	<b>F</b> x1	<b>T</b> 2x
	130x130x65 mm	M8 x 40	Ø50x25 mm	Ø5x40 mm	5 mm	Ø8x36 mm



<b>2</b>	<b>A</b> x2	<b>B</b> x6	<b>C</b> x2	<b>D</b> x2	<b>F</b> x1	<b>T</b> 2x
	130x130x65 mm	M8 x 40	Ø50x25 mm	Ø5x40 mm	5 mm	Ø8x36 mm





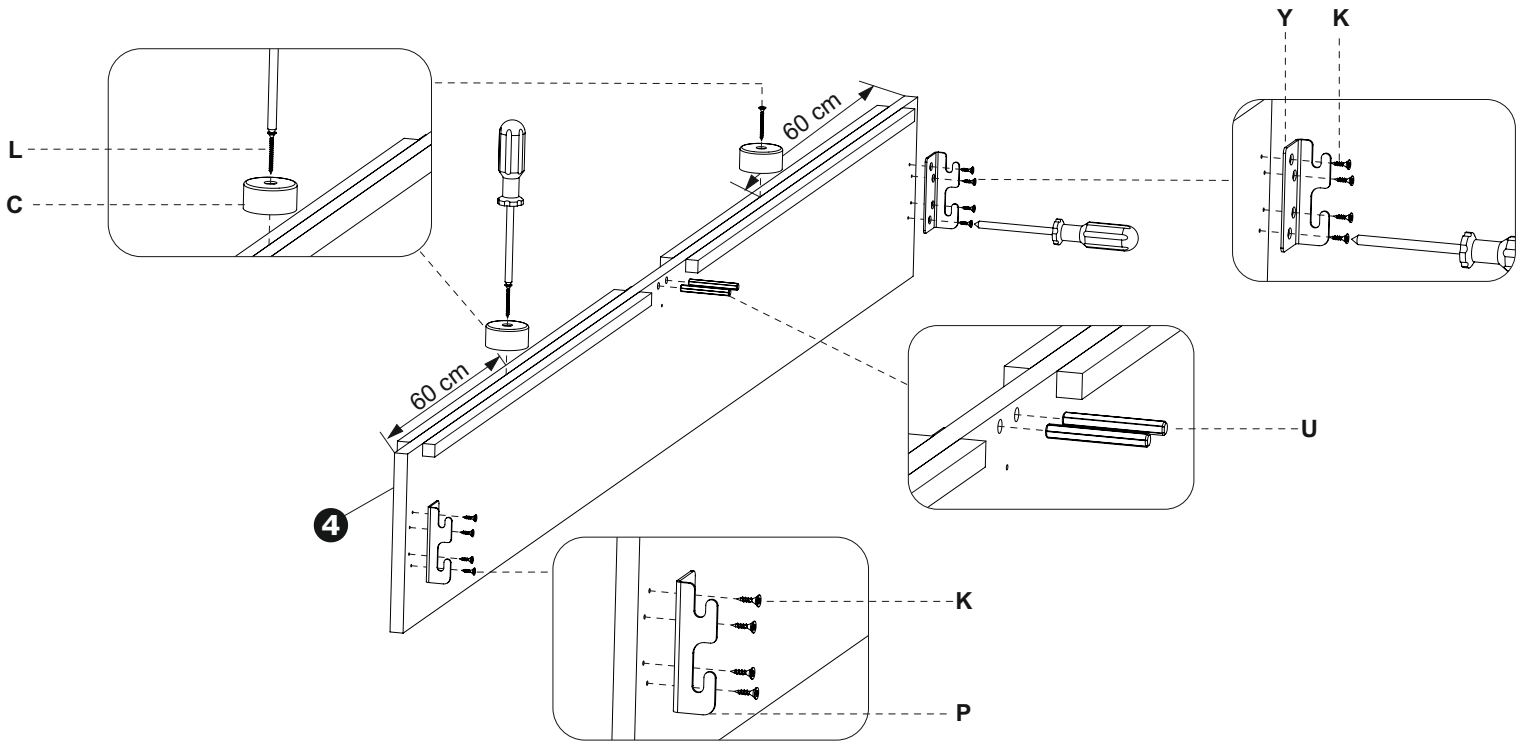

**3**

<b>C</b> x2  Ø50x25 mm	<b>K</b> x8  Ø4x16 mm	<b>L</b> x2  Ø4x40 mm	<b>P</b> x1  90x40x30 mm	<b>U</b> 2x  Ø8x60 mm	<b>Y</b> 1x  90x40x30 mm
---	--	--	---	---	---



**4**

<b>C</b> x2  Ø50x25 mm	<b>D</b> x2  Ø5x40 mm	<b>L</b> x4  Ø4x40 mm	<b>R</b> x1  90x 20 mm
---	--	--	---

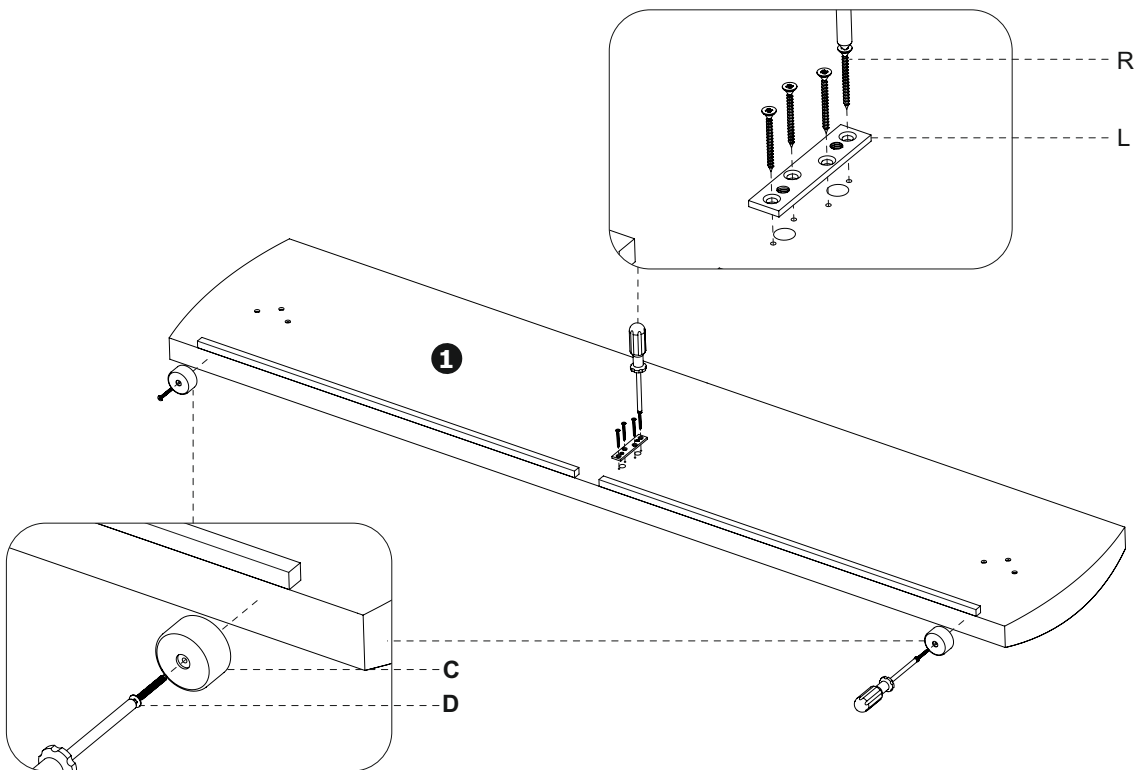

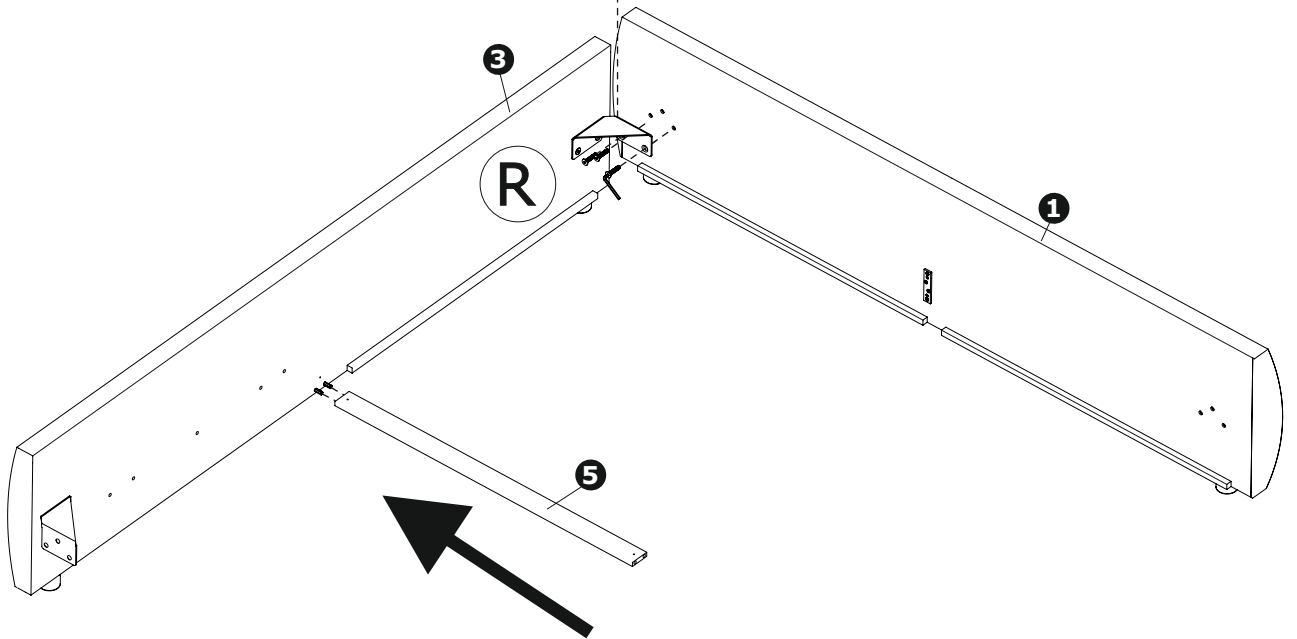
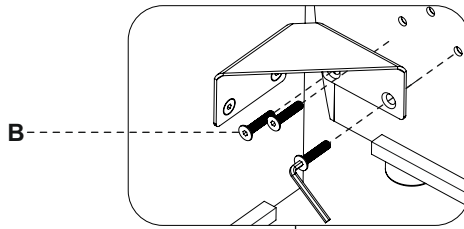
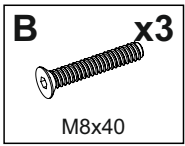

5

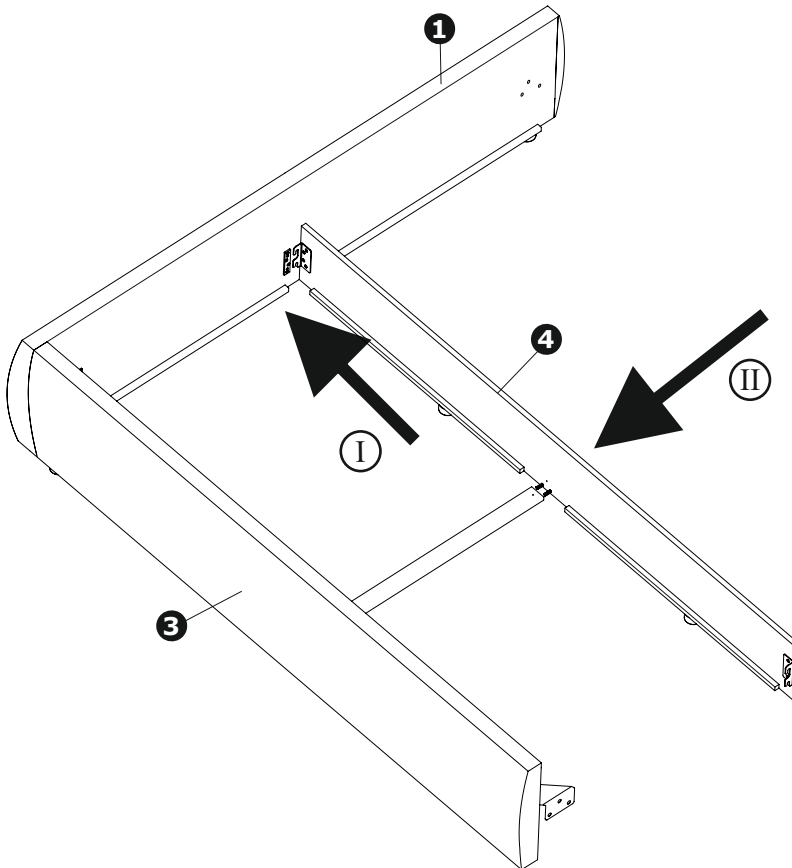

6



7

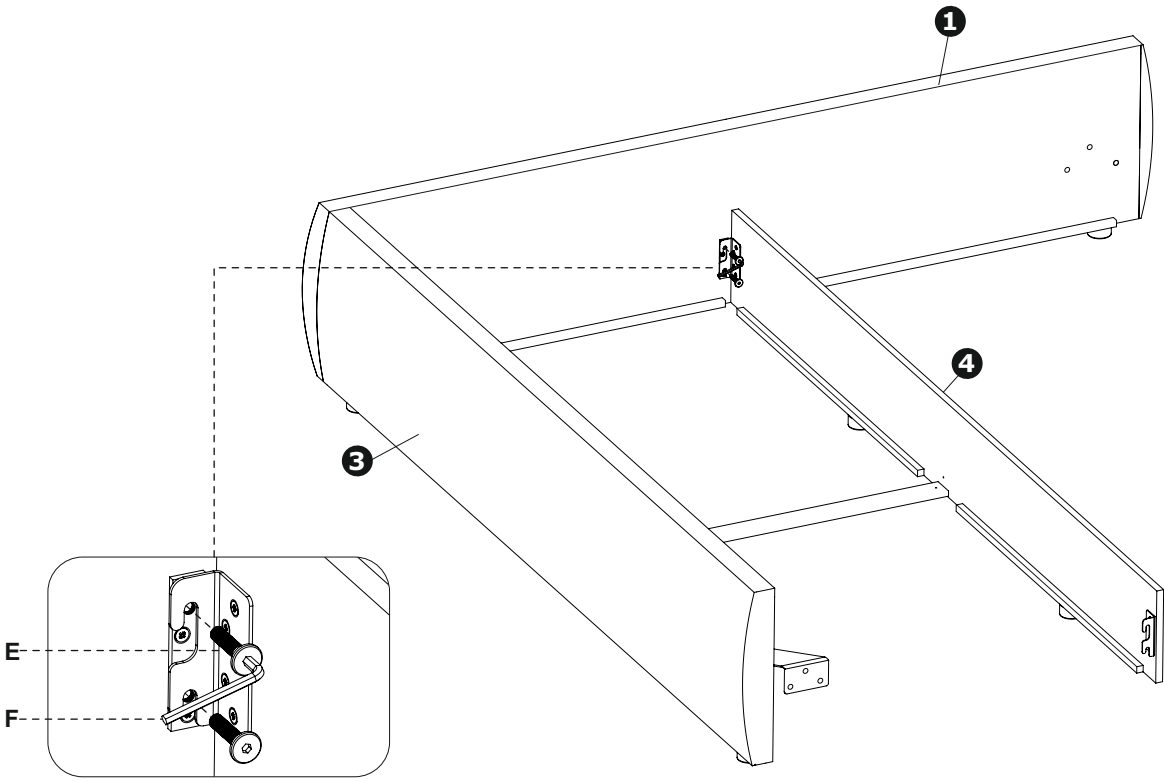

<b>E</b>  M8x35	<b>x2</b>	<b>F</b>  5 mm	<b>x1</b>
---	-----------	---	-----------

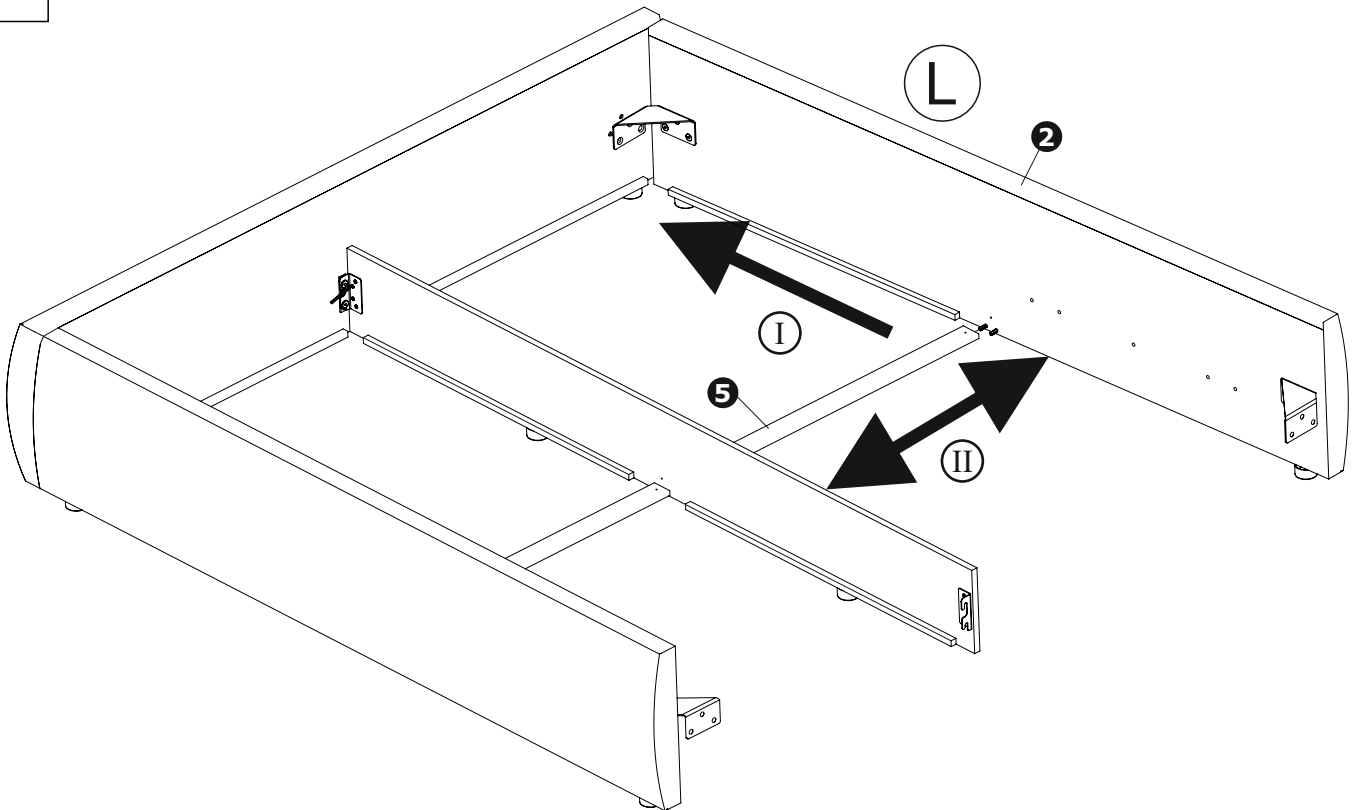

8

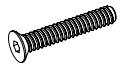

9



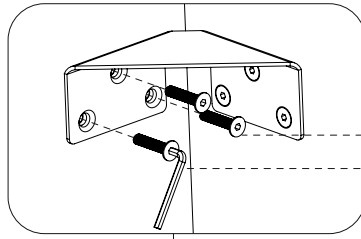

<b>B</b>	<b>x3</b>	<b>F</b>	<b>x1</b>
			
M8x40		5 mm	

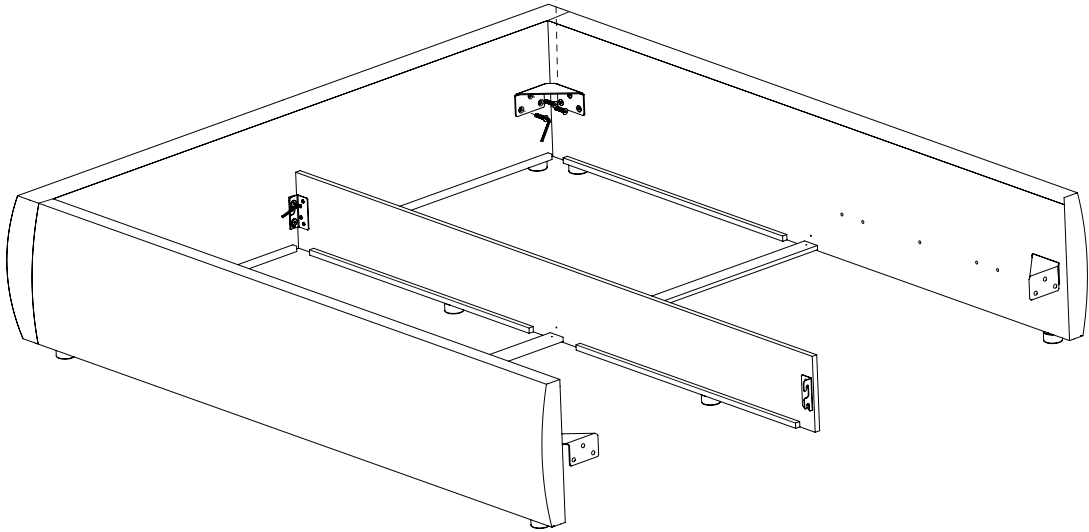

B  
F



10

<b>C</b>	<b>x2</b>	<b>D</b>	<b>x2</b>	<b>L</b>	<b>x4</b>	<b>R</b>	<b>x1</b>
							
Ø50x25 mm		Ø5x40 mm		Ø4x40 mm		90x20 mm	

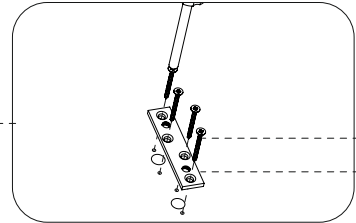

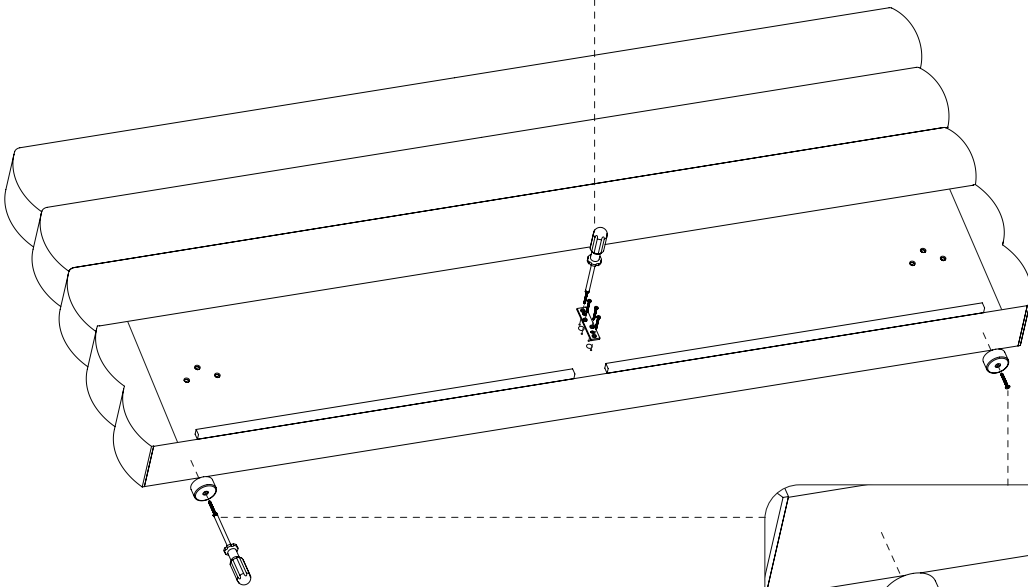

L  
R

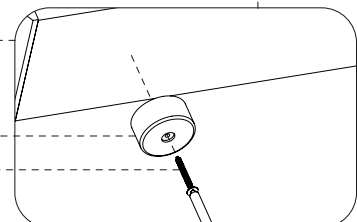

C  
D

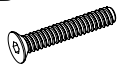

11

<b>B</b>  M8x40	<b>E</b>  M8x35	<b>F</b>  5 mm
--	--	---

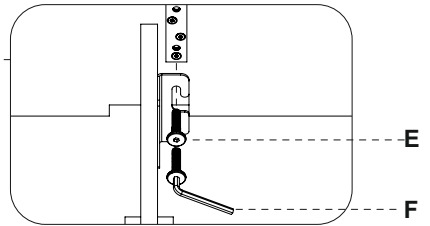
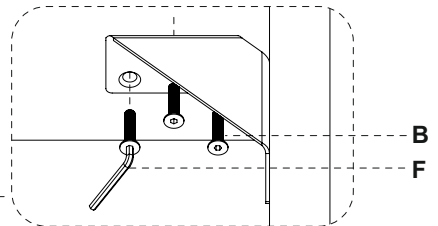
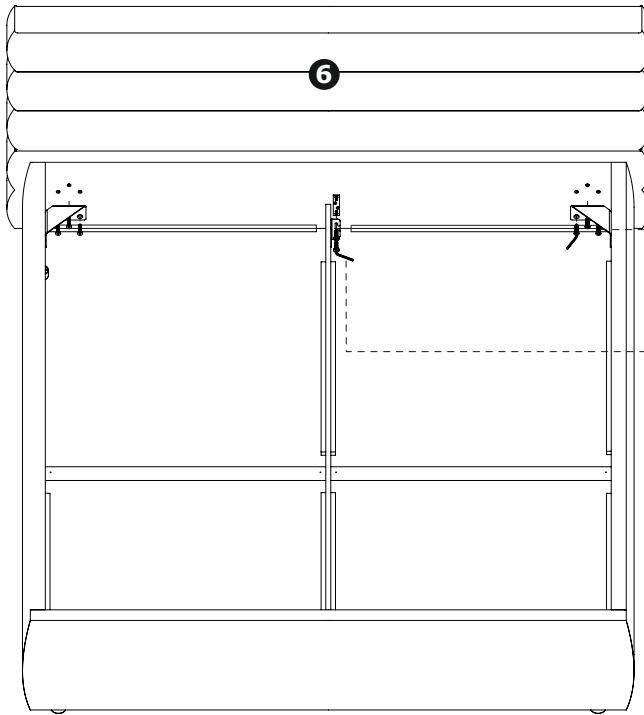

12

<b>S</b>  Ø46x5 mm	<b>x4</b>
---	-----------

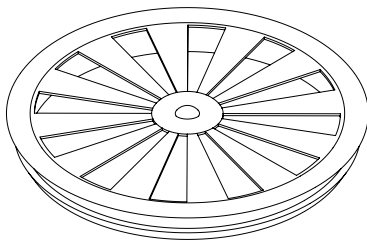
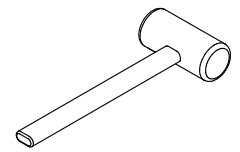

Ⓘ

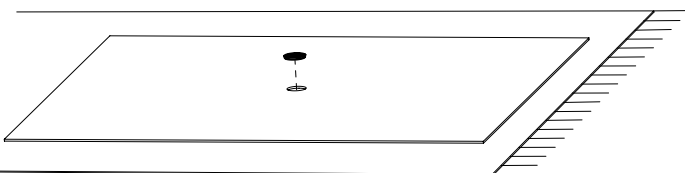

Ⓜ

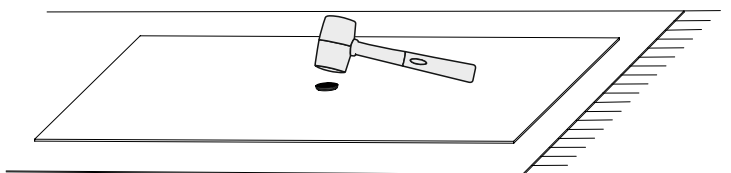

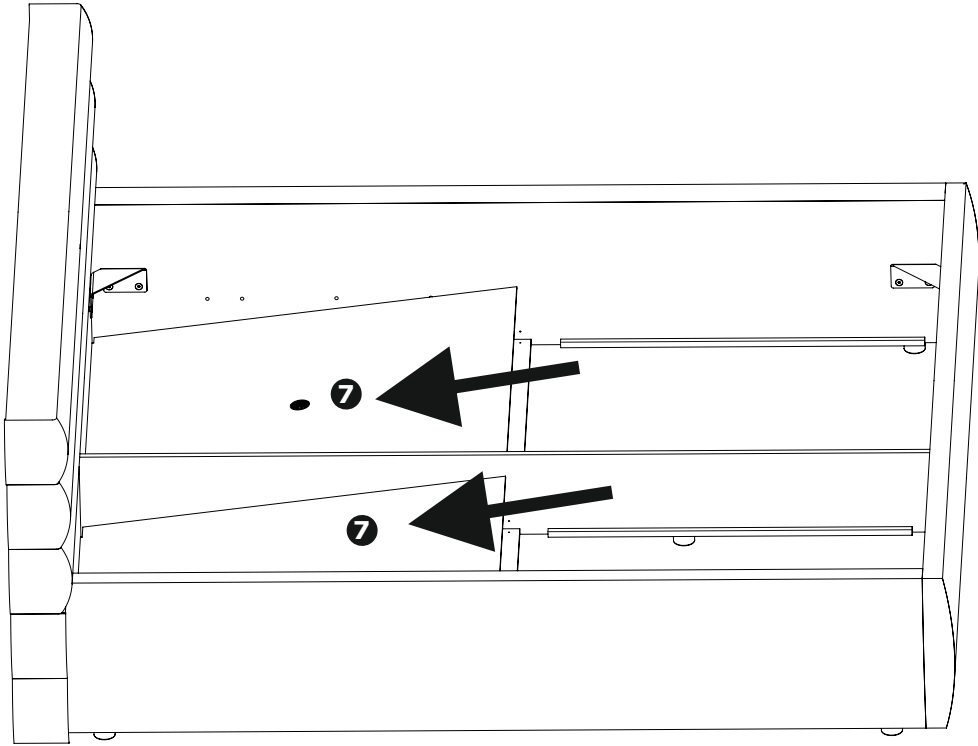

13

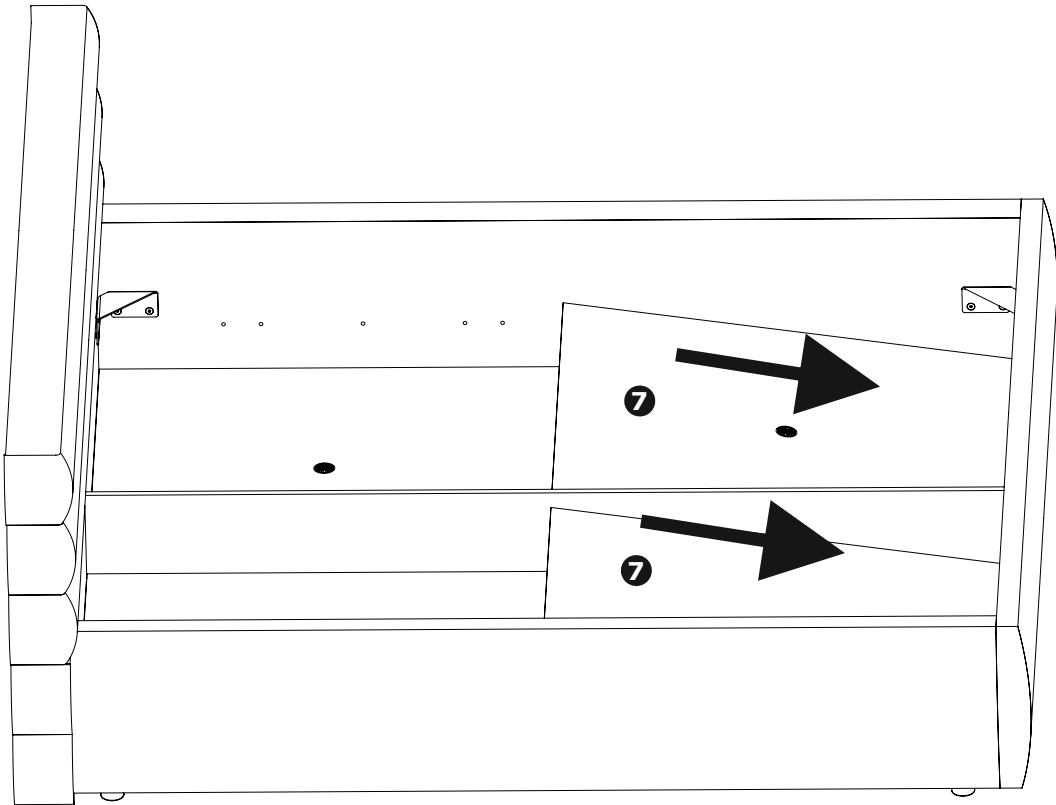

14



15

<b>K</b>	<b>x4</b>	<b>M</b>	<b>x4</b>
			
Ø4x16 mm		20x25x25 mm	

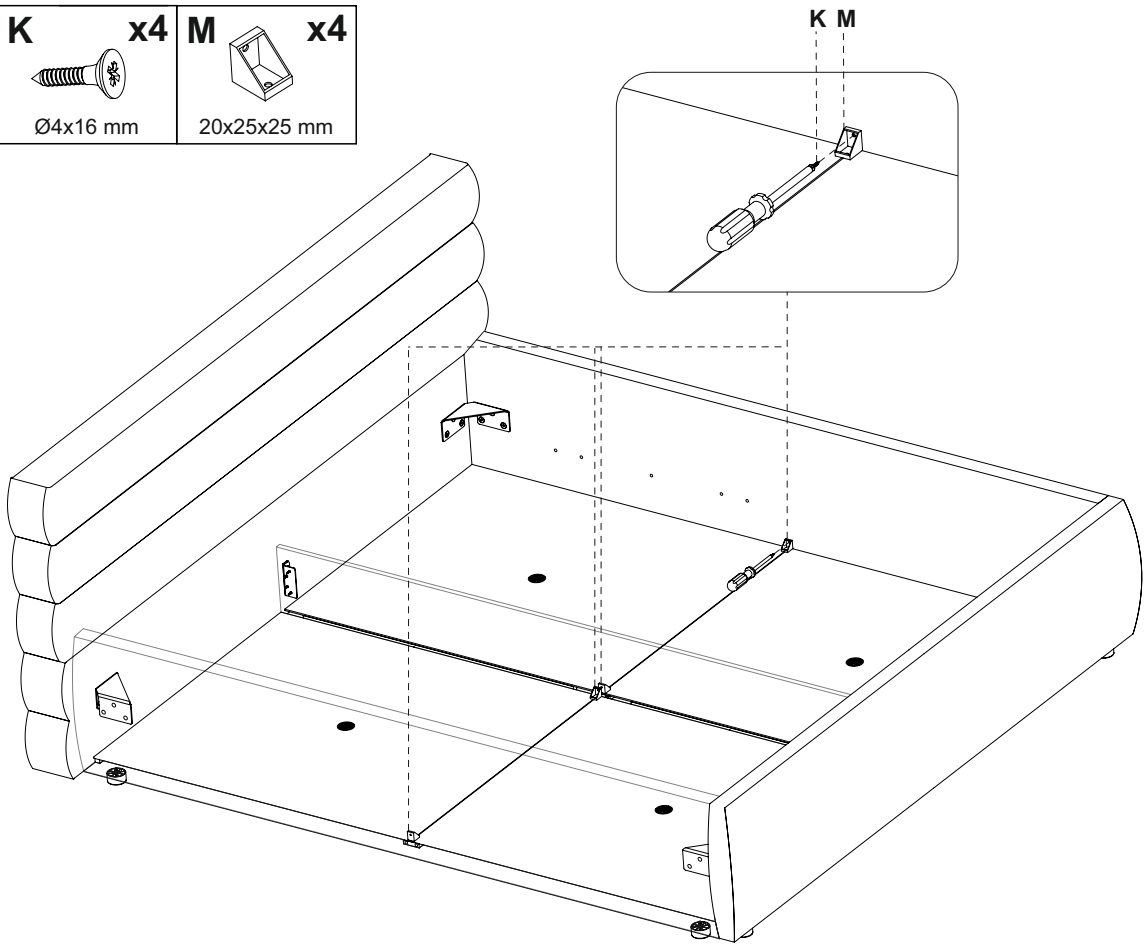

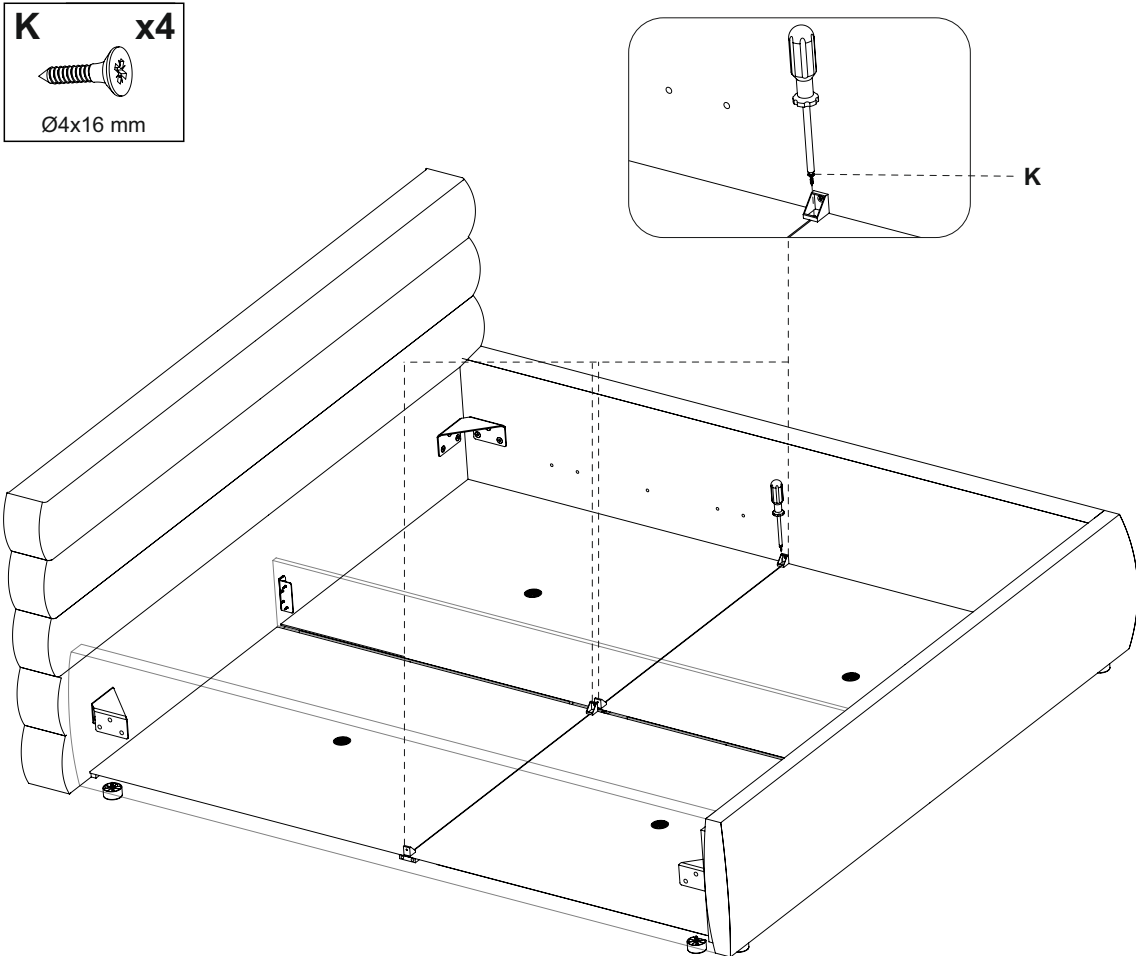

16

<b>K</b>	<b>x4</b>
	
Ø4x16 mm	



17

<b>K</b>	<b>x8</b>	<b>M</b>	<b>x8</b>
			
Ø4x16 mm		20x25x25 mm	

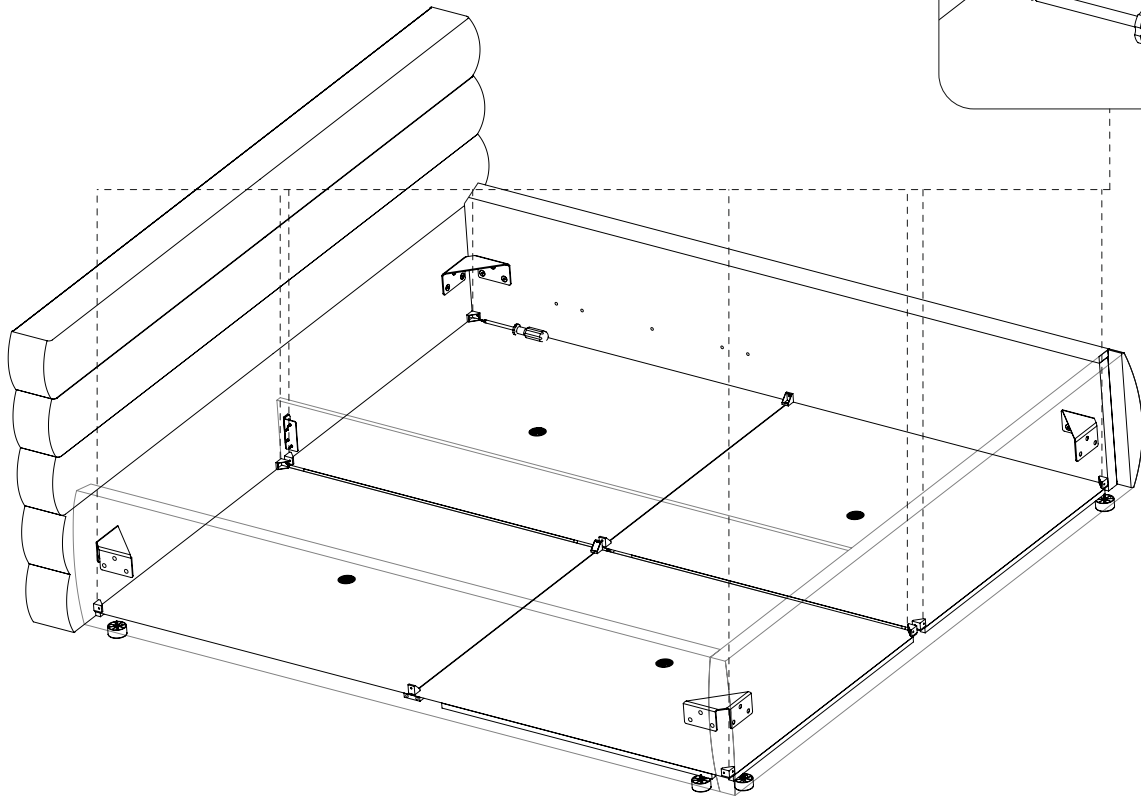
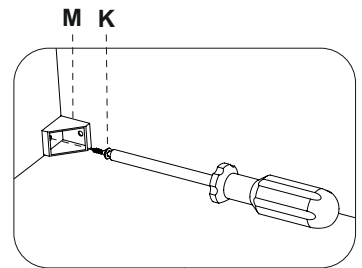

18

<b>N</b>	<b>x4</b>
	
16x27x10 mm	

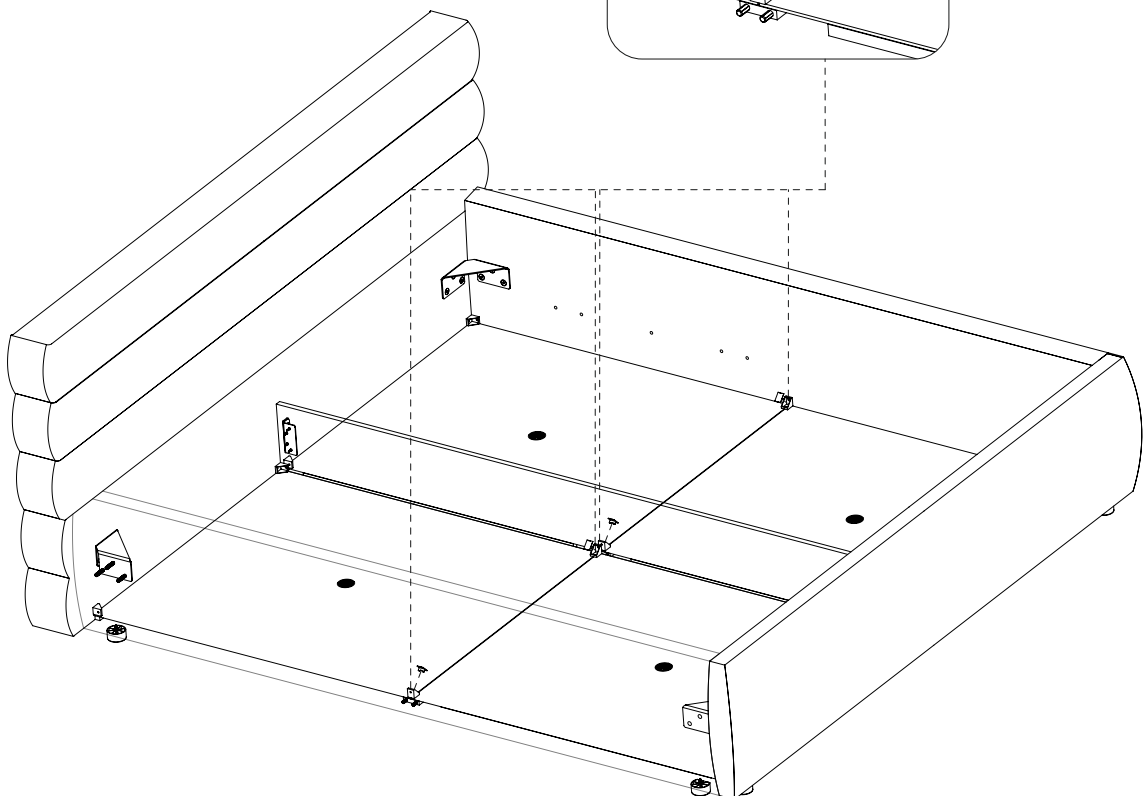
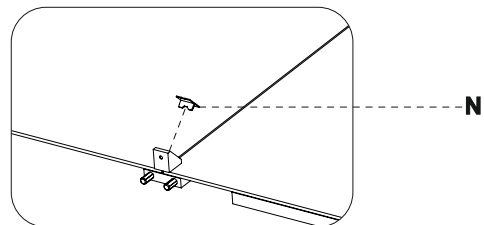

19

**N** x8  
16x27x10 mm

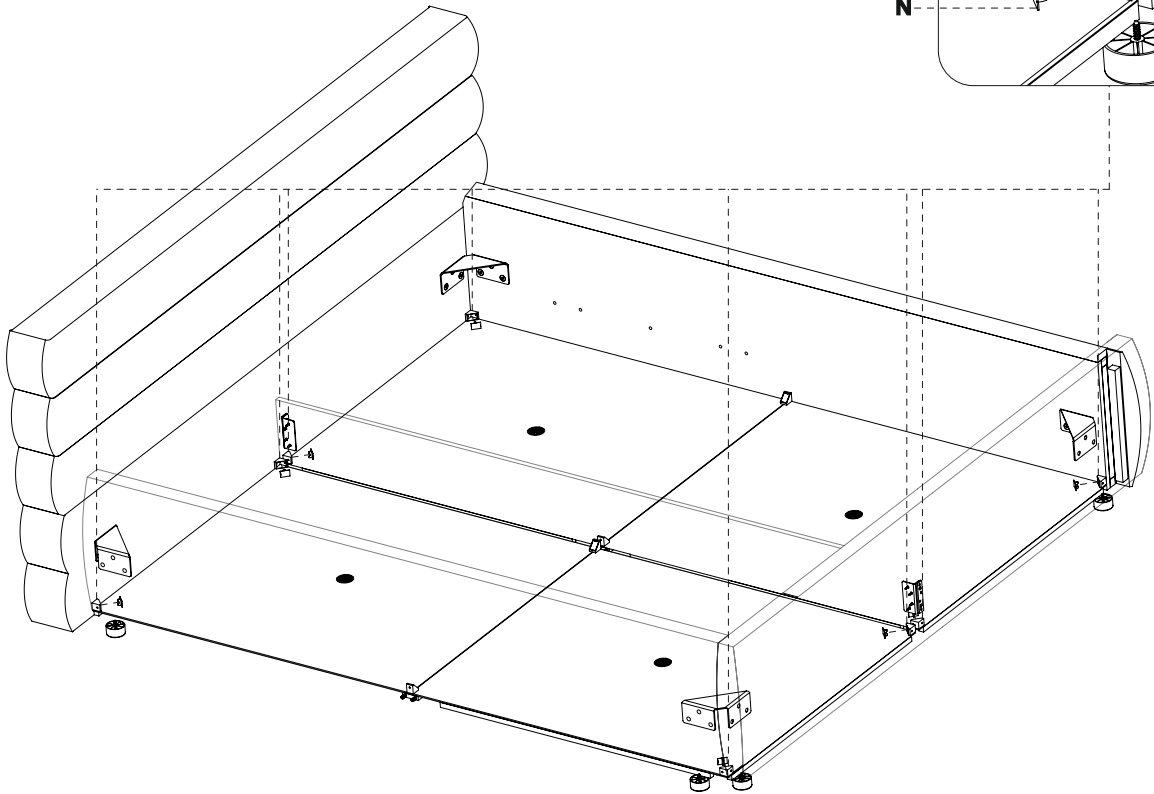
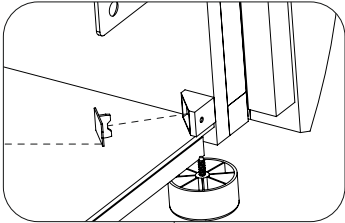

20

**G** x8  
Ø30x3 mm

**W** x1  
90x17 mm

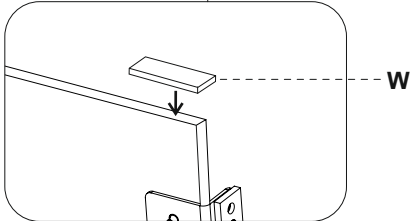
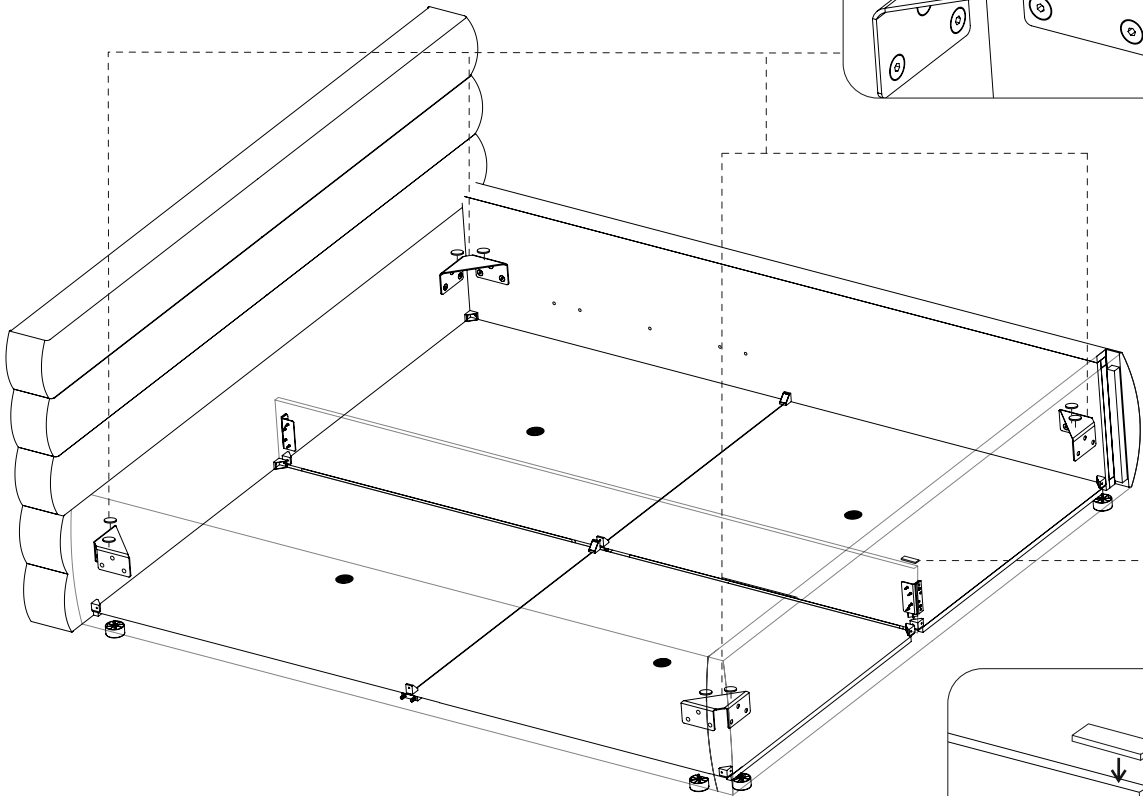
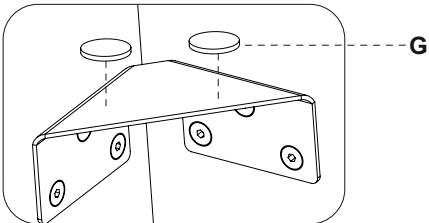

21

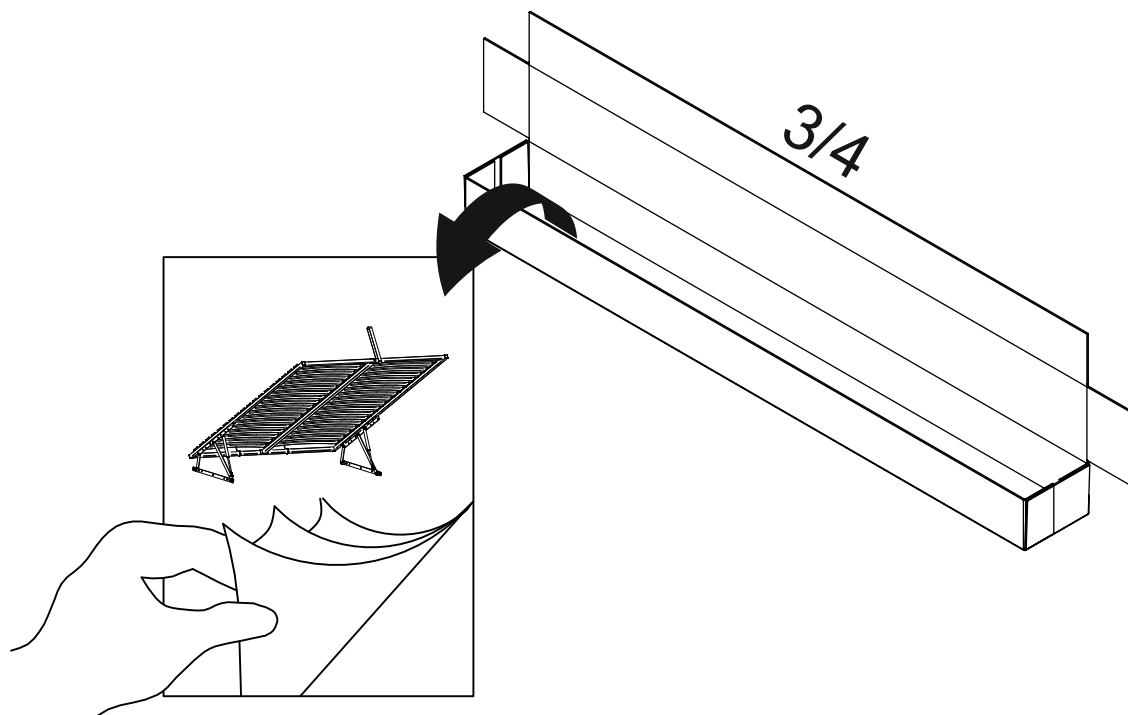

22

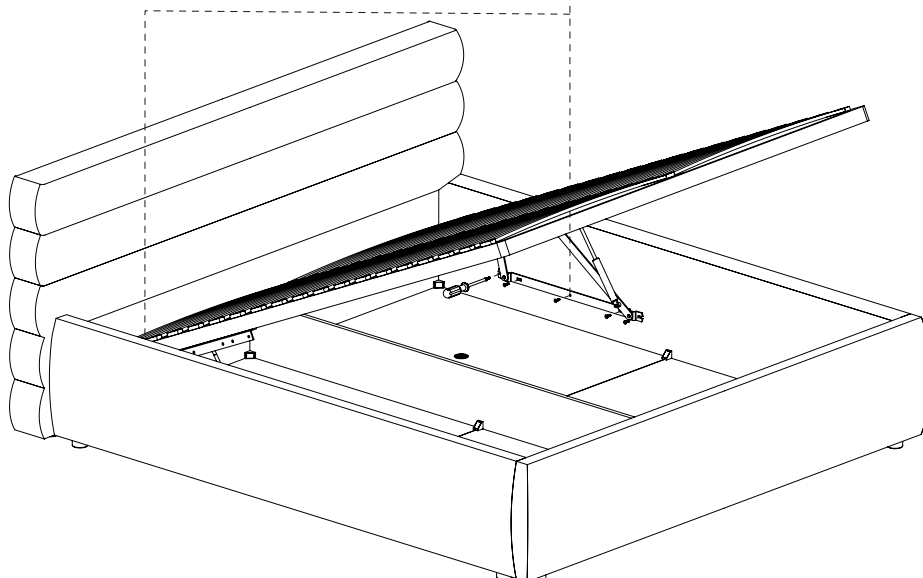
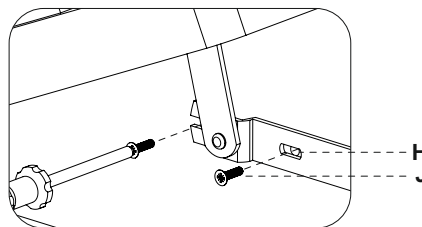
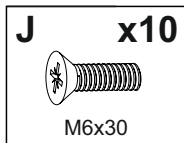
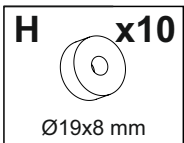

23

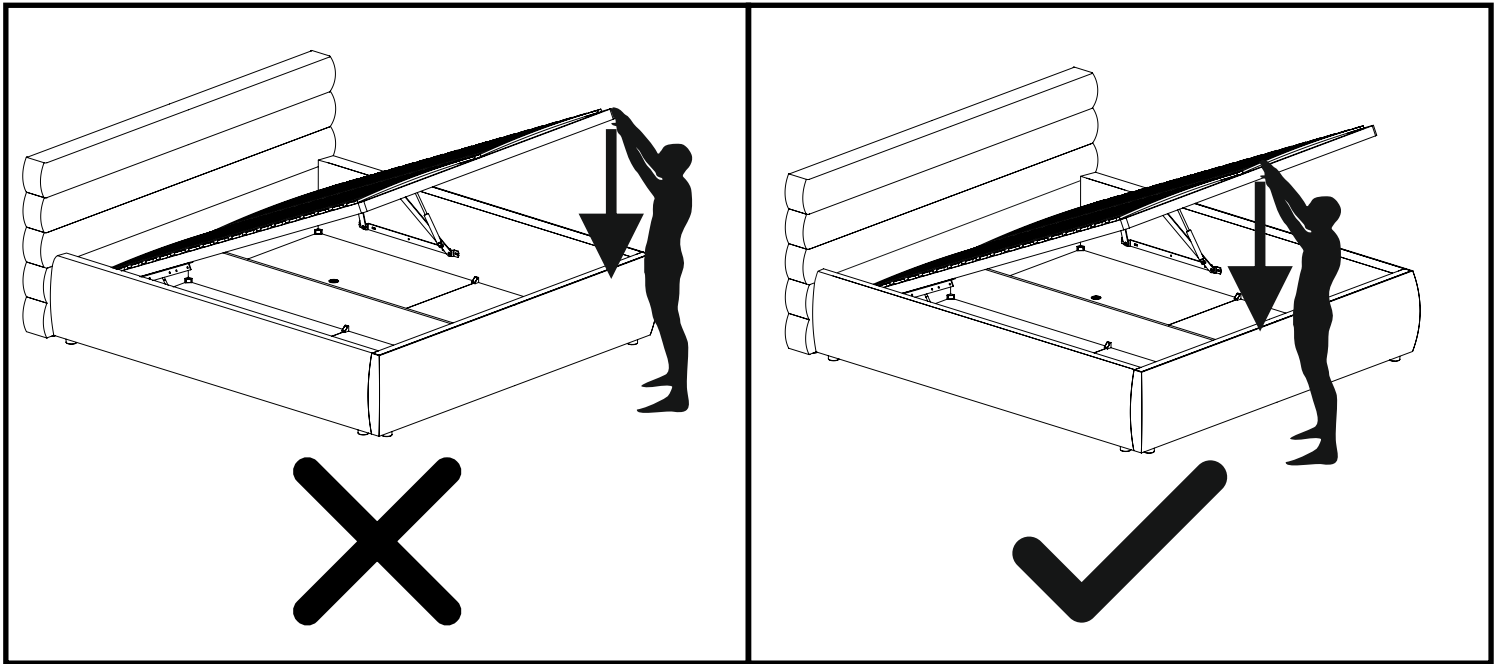

24

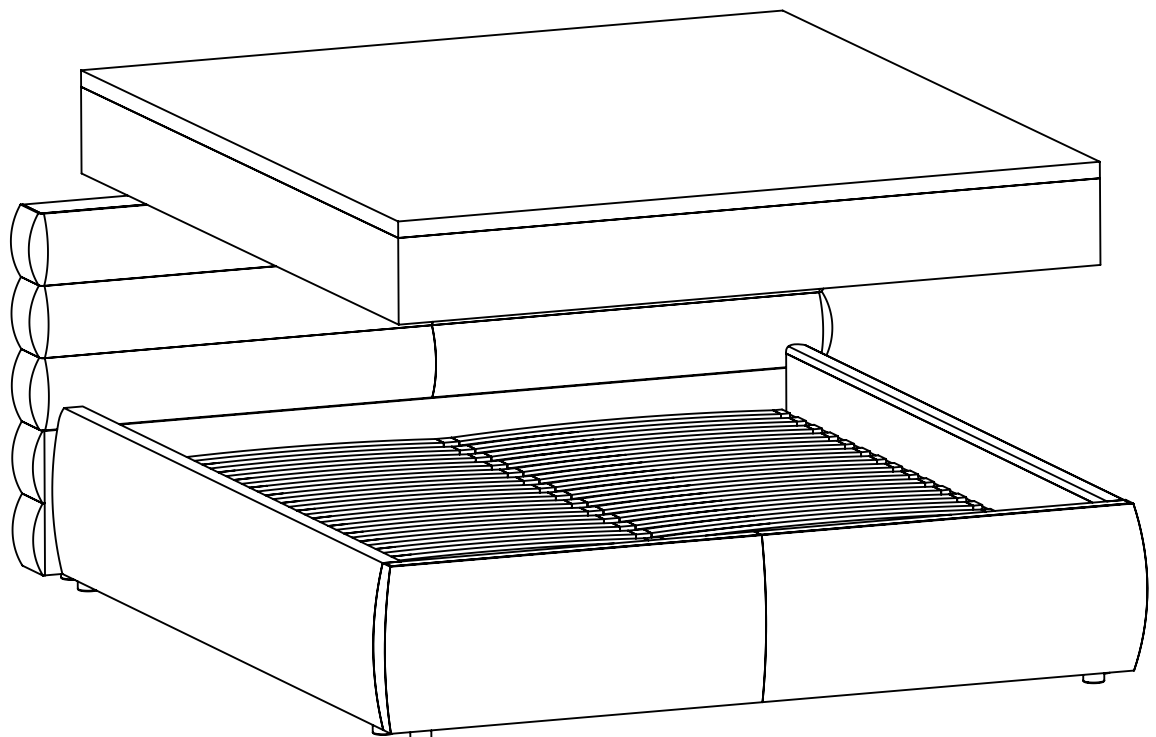

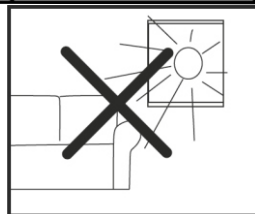
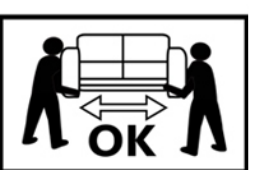
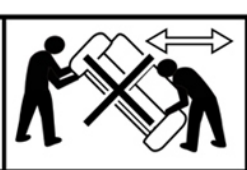
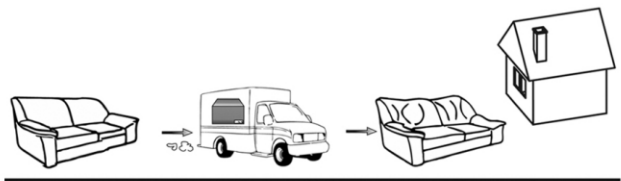
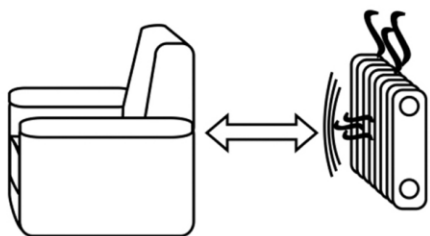
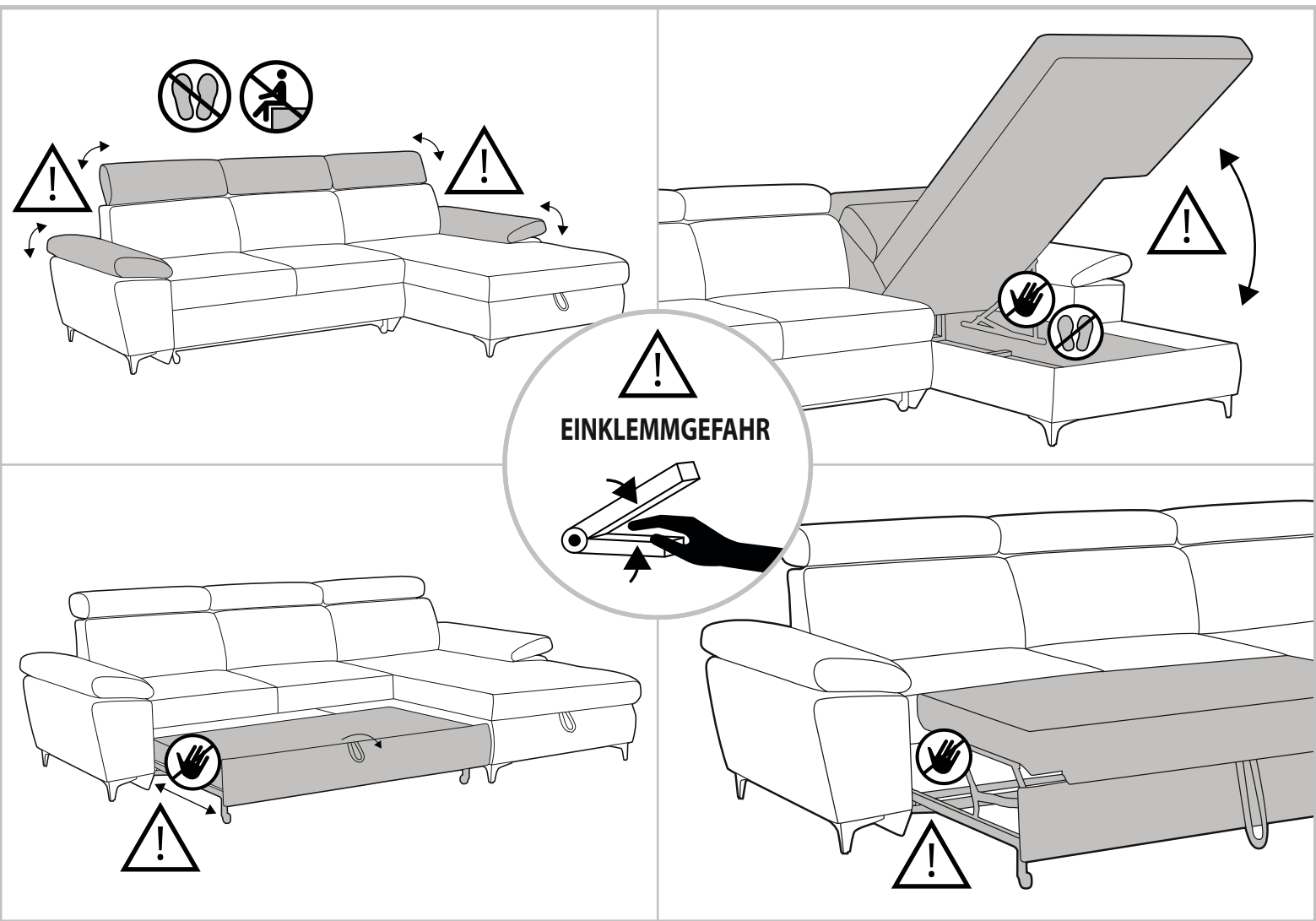

## DE Pfleheinweise

	Metall	Kunststoff	Textil
Weiches, leicht feuchtes Tuch	<input checked="" type="checkbox"/>	<input checked="" type="checkbox"/>	<input checked="" type="checkbox"/>
Seifenwasser	<input checked="" type="checkbox"/>	<input checked="" type="checkbox"/>	<input checked="" type="checkbox"/>
Wasser mit Reinigungsmittel	<input checked="" type="checkbox"/>	<input checked="" type="checkbox"/>	<input type="checkbox"/>
Kratzfreie Scheuerschwamm	<input checked="" type="checkbox"/>	<input checked="" type="checkbox"/>	<input type="checkbox"/>
Herstellerspezifische Pflege	<input type="checkbox"/>	<input type="checkbox"/>	<input checked="" type="checkbox"/>

## Warnhinweise

Vor jeder Pflege sorgfältig entstauben	<input checked="" type="checkbox"/>	<input checked="" type="checkbox"/>	<input checked="" type="checkbox"/>
Flecken müssen sofort entfernt werden	<input type="checkbox"/>	<input type="checkbox"/>	<input checked="" type="checkbox"/>
Nie niemals abrasive Mittel verwenden (Pulver, Stahlwolle)	<input checked="" type="checkbox"/>	<input checked="" type="checkbox"/>	<input checked="" type="checkbox"/>
Ne jamais utiliser de solvant	<input checked="" type="checkbox"/>	<input checked="" type="checkbox"/>	<input checked="" type="checkbox"/>
Nicht nass machen	<input type="checkbox"/>	<input type="checkbox"/>	<input type="checkbox"/>
Nicht mit Hochdruckreiniger reinigen (Außenprodukte)	<input type="checkbox"/>	<input type="checkbox"/>	<input type="checkbox"/>
Spezifischer Hinweis	<input type="checkbox"/>	<input type="checkbox"/>	<input checked="" type="checkbox"/>

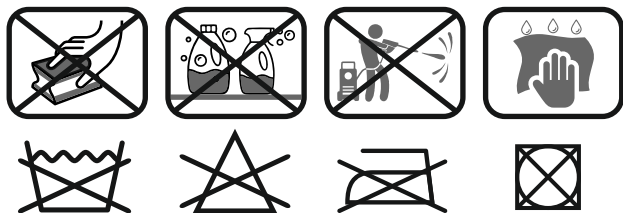

## EN Maintenance Instructions

	Metal	Plastic	Textile
Slightly damp soft cloth	<input checked="" type="checkbox"/>	<input checked="" type="checkbox"/>	<input checked="" type="checkbox"/>
Soapy water	<input checked="" type="checkbox"/>	<input checked="" type="checkbox"/>	<input checked="" type="checkbox"/>
Water with detergent	<input checked="" type="checkbox"/>	<input checked="" type="checkbox"/>	<input type="checkbox"/>
Anti-scratch scouring sponge	<input checked="" type="checkbox"/>	<input checked="" type="checkbox"/>	<input type="checkbox"/>
manufacturer specific maintenance	<input type="checkbox"/>	<input type="checkbox"/>	<input checked="" type="checkbox"/>

## Warning

Before any maintenance, clean the dust carefully	<input checked="" type="checkbox"/>	<input checked="" type="checkbox"/>	<input checked="" type="checkbox"/>
Any stain should be cleaned quickly	<input type="checkbox"/>	<input type="checkbox"/>	<input checked="" type="checkbox"/>
Never use an abrasive product (powder, steel wool)	<input checked="" type="checkbox"/>	<input checked="" type="checkbox"/>	<input checked="" type="checkbox"/>
Never use solvent	<input checked="" type="checkbox"/>	<input checked="" type="checkbox"/>	<input checked="" type="checkbox"/>
Do not wet	<input type="checkbox"/>	<input type="checkbox"/>	<input type="checkbox"/>
Do not clean with a high pressure cleaner (outdoor products)	<input type="checkbox"/>	<input type="checkbox"/>	<input type="checkbox"/>
Specific information / warning	<input type="checkbox"/>	<input type="checkbox"/>	<input checked="" type="checkbox"/>

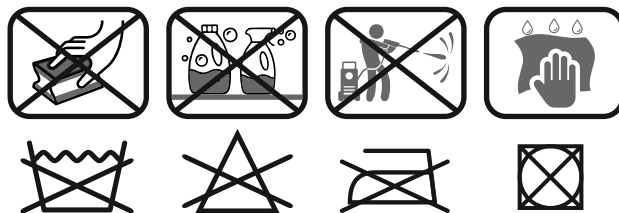

### DE:

Der Stoff Ihres Sitzes neigt naturgemäß zum Pilling. Dies ist kein Mangel, sofern:

- Die Fusseln leicht entfernt werden können oder sich mit der Zeit auflösen,
- Die Anzahl der Fusseln die Ästhetik Ihres Produkts nicht wesentlich beeinträchtigt.

Ein Sitz verändert sich im Laufe der Zeit ganz natürlich in Form und Aussehen durch Einsinken oder Verschiebung der Polsterung. Um das Volumen Ihres Produkts zu erhalten und die Abnutzung gleichmäßig zu verteilen, wird dringend empfohlen:

- Die Kissen regelmäßig zu wenden, sofern möglich,
- Die Sitzflächen unmittelbar nach längerer Nutzung glatt zu streichen und die Kissen leicht zu massieren, um das Volumen wiederherzustellen.

Jegliche Veränderung des Produkts liegt in der Verantwortung des Kunden.

### EN:

Your seat fabric will have a natural tendency to pill. This is not a defect if:

- Pilling can easily be removed or fade over time,
- The number of pills does not significantly affect the aesthetics of your product.

A seat will naturally change shape and appearance as the padding sags or shifts over time. In order to prolong the shape of your product and evenly distribute wear, it is strongly recommended:

- Turn the cushions over regularly, if possible,
- To smooth the surface of the seats immediately after prolonged use and to massage the cushions to restore their swelling.

Any modification of the product engages the responsibility of the customer