

ARES

ARES S.r.l.

Zona artigianale "Gli Ulivi"
Sestino (AR)

www.aresmobilificio.it

COD.0WMMBI077GSGSS

(IT) ISTRUZIONI DI MONTAGGIO
(GB) ASSEMBLING INSTRUCTIONS
(FR) NOTICE DE MONTAGE
(SLO) NAVODILA ZA MONTAŽO
(SRB) UPUTSTVO ZA MONTAŽU

(D) MONTAGEANLEITUNG
(ES) INSTRUCCIONES DE MONTAJE
(P) INSTRUÇÕES DE MONTAGEM
(HR) UPUTE ZA MONTAZU
(RO) FOAIE CU INSTRUCȚIUNI
(BG) ИНСТРУКЦИИ ЗА СГЛОБЯВАНЕ

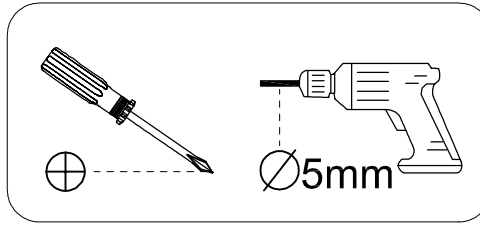
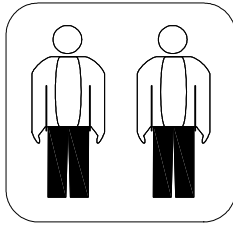
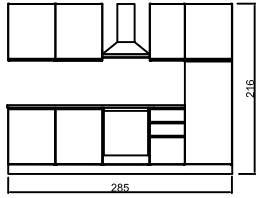

120 MIN

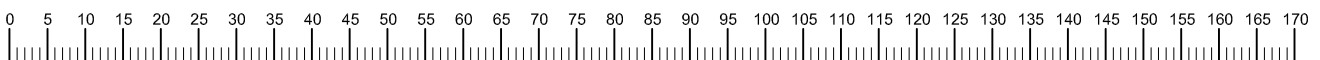
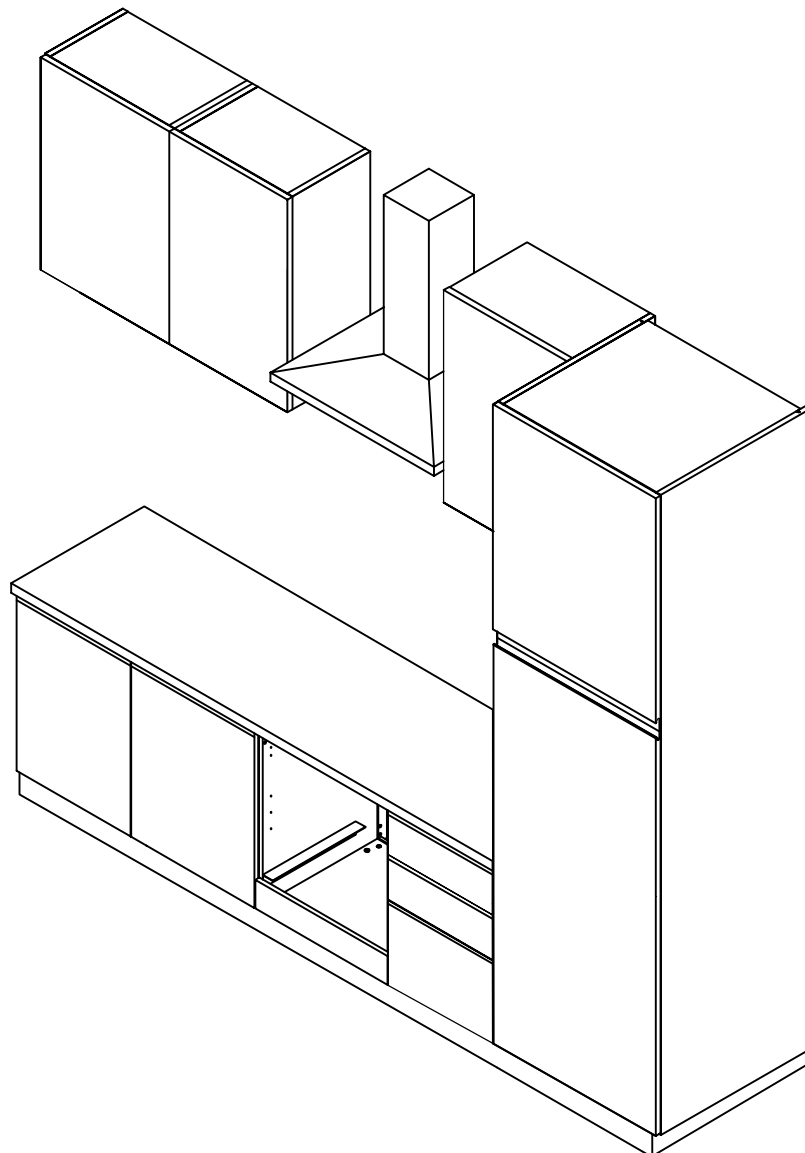

Française – Suisse

CONSEILS DE MONTAGE

1. Bien étudier la notice de montage;
2. Repérez les pièces constituant votre meuble;
3. Regroupez et contrôlez la quincaillerie;
4. Munissez-vous de l'outillage nécessaire;
5. Aménagez-vous une zone de montage;
6. Procédez au montage.

CONSEILS D'ENTRETIEN

1. Dépoussiérez soigneusement;
2. Humecter un chiffon doux et propre d'eau légèrement savonneuse (ou détergent)

Ne jamais forcer les assemblages
Resserrez les vis après quelques temps d'usage
Garder votre notice de montage
Si une pièce devait a manquer, le plus simple est de contacter votre magasin directement
Le poids maximum autorisé sur les boîtes de tiroir est de 10 kg

Ne jamais utiliser de produits abrasifs:
poudre, laine d'acier, solvants

English

ASSEMBLING ADVICE

1. Study careful the assembly instructions;
2. Characterize pieces that form the furniture;
3. Group and control the ironware;
4. Take the necessary tools for the assembly;
5. Prepare an assembly zone;
6. Proceed with the assembly.

MAINTENANCE ADVICE

1. Dust accurately;
2. Damp a cleaned and soft cloth with water and little detergent.

Never force the assemblages
Screw the screws after a long period
Conserve the assembly instructions
If one or more pieces are missing, please contact the store
Maximum weight allowed on drawer boxes is 10kg.

Do not use abrasive products: powder, steel wool, solvents

Italiano – Svizzera

CONSIGLI DI MONTAGGIO

1. Studiare bene le istruzioni di montaggio;
2. Controllare che tutti i pezzi che costituiscono il mobile siano presenti;
3. Raggruppare e controllare la ferramenta;
4. Munirsi degli utensili necessari al montaggio;
5. Allestire una zona di montaggio;
6. Procedere al montaggio.

CONSIGLI PER LA MANUTENZIONE

1. Spolverare accuratamente;
2. Inumidire con acqua leggermente insaponata uno straccio morbido e pulito.

Non forzare mai gli assemblaggi
Stringere le viti dopo un periodo d'uso
Conservare le istruzioni di montaggio
Se un pezzo dovesse mancare o essere rotto, contattare il punto vendita
Il peso massima supportato dai cassetti è di 10kg.

Non utilizzare mai prodotti abrasivi:
polvere, lana di acciaio, solventi

Deutsch – Schweiz

MONTAGE ANLEITUNG

1. Die Montageanleitung genau durchlesen;
2. Die Einzelteile des Möbels stück ermitteln;
3. Die Beschläge zusammenlegen und prüfen;
4. Das Notwendige werkzeug zurechtlegen;
5. Einem Montagebereich freimachen;
6. Das Möbels stück zusammenbauen.

PFLEGEHINWEISE

1. Sorgfältig entstauben;
2. Mit einem weichen, sauberen und feuchtem Tuch und leichter selfentaue reinigen

Niemals die Verbindungen zu stark anziehen
Die Schrauben nach Lang Zeit des Gebrauchs erneut festziehen
Die Montageanleitung gut aufbewahren
Wenn ein Teil fehlen, ist Sie das beste Verständigungsmittel mit Ihrem Geschäft
Das maximale Gewicht auf Schubladenkästen erlaubt ist 10 kg

Benutzen Sie keine Scheuermittel wie
Pulver, Stahlwolle, Lösungsmittel

Español

CONSEJOS PARA EL MONATJE

1. Estudie atentamente el manual de montaje;
2. Localice las piezas que constituyen su mueble;
3. Reuna y contrle los tornillos;
4. Equipese de las herramientas necesarias;
5. Prepare una zona de montaje;
6. Realice el montaje.

CONSEJOS PARA EL MANTENIMIENTO

1. Despolvorear cuidadosamente;
2. Humedecer un pano suave y limpio con agua ligeramente enjabonada.



No fuerce nunca en las uniones
Apriete los tornillos despues de cierto tiempo de utilizacion
Conserve su manual de montaje
Si faltara una pieza, seia la manera mas facil de comunicar con la tienda
El peso máximo permitido en las cajas de cajón es de 10 kg

Portugues

CONSELHOS DE MONATAGEM

1. Estuda bem as instruções de montagem;
2. Junta as peças que constituem o seu móvel;
3. Reagrupa e controla a quinquilharia;
4. Equipa-se da ferramenta necessária;
5. Cria-se uma zona de montagem;
6. Proceda á montagem.

CONSELHOS DE MONTAGEM

1. Eliminar bem o po;
2. Umedecer um pano suave e limpo con agua e um pouco de sabao.



Nunca esforçar as montagem
Apertar os pafusos após un tempo de utilização
Guardar as instruções de montagem, si faltara alguna pieza, lo mas aconsejable es contactar con la tienda
O peso máximo permitido em caixas de gaveta é de 10 kg



Nunca utilizar productos abrasivos pos, la de aço, solventes

Hrvatski

SAVJETI ZA MONTAZU

1. Porucite pazljivo upute za montazu;
2. Prekontrolirajte po uputama da li imate sve dijelove;
3. Prekontrolirajte da li imate sve vijke, matice i ostale metalne dijelove;
4. Osigurajte potreban alat za sastavljanje;
5. Oslobodite odgovarajuci prostor za montiranje;
6. Ukoliko ste provjerili sve gore navedeno mozete zapoceti montazu.

SAVJETI ZA ODRZAVANJE

1. Uklanjajte redivito prasinu i necistoce;
2. Cistite uvijek s mlo vode i blagog deterdzenta te mekom i cistom krpom.



Prilikom montiranja, nemojte nasilno pokusavati spojiti dijelove
Odvijati vijke nakon duzeg stajanja montiranog proizvod
Ukoliko Vam nedostaje koji dio, molimo Vas kontaktirajte trgovinu u kojoj ste namjestaj kupili
Ladica ima nosivost od maksimalnih 10kg



Nemojte koristiti abrazivne krpe, pudere, matalnu vunu ili sredstva koja mogu otopiti površinu namjestaja

SLOVENŠČINA

NAVODILA ZA MONTAŽO

1. Pozorno preberite navodila za montažo;
2. Določite posamezne dele pohištva;
3. Preverite, ali imate vse vijake, matice in ostale kovinske dele;
4. Pripravite potrebna orodja;
5. Pripravite in počistite prostor, kjer boste pohištvo sestavljali;
6. Sestavite pohištvo.

NAVODILA ZA NEGO

1. Redno brišite prah.
2. Očistite z mehko, čisto in vlažno krpo ter uporabite malo milnice.



Delov ne zategujte preveč.
Po daljšem času ponovno zategnite vijake.
Navodila za montažo hranite na varnem mestu.
Če kakšen del manjka, kontaktirajte prodajalno, v kateri ste pohištvo kupili.
Predali imajo največjo nosilnost 10 kg.



Ne uporabljajte abrazivnih krp, praškov, jeklene volne ali sredstev, ki lahko raztopijo površino pohištva.



БЪЛГАРСКИ

Инструкция за монтаж:

1. Запознайте се внимателно с инструкциите за монтаж;
2. Уверете се, че всички части на артикула са налични;
3. Уверете се, че всички крепежни елементи (винтове, гайки и др.) са налице;
4. Осигурете необходимите за сглобяването инструменти;
5. Освободете подходящо и достатъчно място за сглобяването;
6. Продължете към монтажа.

Съвети за поддръжка:

1. Почиствайте старателно от прах;
2. Използвайте мека и чиста кърпа и подходящ почистващ препарат.



В никакъв случай не пренатягайте!
След известно време затегнете винтовете отново.
Запазете инструкцията за монтаж.
Ако някоя част липсва или е счупена, свържете се с магазина, от който сте закупили мебелите.
Максималната товарносимост на чекмеджетата е 10 кг.

Не използвайте абразивни препарати:
прахообразни продукти, стоманена вата,
разтворители!

ROMANIA

SFATURI DE MONTAJ

1. Studiați cu atenție instrucțiunile de asamblare;
2. Verificați dacă toate piesele care compun mobilierul sunt prezente;
3. Grupați și verificați hardware-ul;
4. Echipați-va cu sculele necesare asamblării;
5. Amenajează o zonă de asamblare;
6. Continuați cu asamblarea.



Nu forțați niciodată ansamblurile.
Strângeți șuruburile după o perioadă de utilizare.
Păstrați instrucțiunile de asamblare
Dacă o piesă lipsește sau este ruptă, contactați punctul de vânzare.
Greutatea maximă suportată de sertare este de 10 kg.

Nu utilizați niciodată praf abraziv, lână de sticlă sau solvenți.

SFATURI DE ÎNTREȚINERE

1. Curatați praful bine;
2. Umeziți cu apă ușor săpun o cârpă moale și curată.

SRPSKI

UPUTSTVO ZA MONTAŽU

1. PAŽLJIVO PROČITAJTE UPUTSTVO ZA MONTAŽU;
2. PREKONTROLIŠITE PREMA UPUTSTVU DA LI IMATE SVE POTREBNE DELOVE;
3. PREKONTROLIŠITE DA LI IMATE SVE ŠRAFOVE, MATICE I OSTALE METALNE DELOVE;
4. OSUGURAJTE POTREBAN ALAT ZA SASTAVLJANJE;
5. PRIPREMITE ODGOVARAJUĆI PROSTOR ZA MONTIRANJE;
6. UKOLIKO STE PROVERILI SVE GORE NAVEDENO MOŽETE ZAPOČETI MONTAŽU.



PRILIKOM MONTIRANJA NE POKUŠAVATI NASILNO SPAJANJE DELOVA.
NAKON DUŽEG VREMENA KORIŠĆENJA PROIZVODA, ŠRAFOVE PONOVRNO PRIČVRSTITI.
UKOLIKO VAM NEDOSTAJE ODREĐENI DEO, MOLIMO VAS DA KONTAKTIRATE PRODAJNI CENTAR GDE STE NAMEŠTAJ KUPILI. FIOKA IMA MASKIMALNU NOSIVOST 10 KG.

NE KORISTITI ABRAZIVNE KPPE, PUDERE, ČELIČNU VUNU ILI SREDSTVA KOJA MOGU OŠTETITI POVRŠINU NAMEŠTAJA.

SAVETI ZA ODRŽAVANJE

1. UKLANJAJTE REDOVNO PRAŠINU I NEČISTOĆU;
2. ODRŽAVANJE MEKOM I VLAŽNOM KRPOM UZ UPOTREBU BLAGOG DETERDŽENTA.

(IT) ISTRUZIONI DI MONTAGGIO
(GB) ASSEMBLING INSTRUCTIONS
(FR) NOTICE DE MONTAGE
(SLO) NAVODILA ZA MONTAŽO
(SRB) UPUTSTVO ZA MONTAŽU

(D) MONTAGEANLEITUNG
(ES) INSTRUCCIONES DE MONTAJE
(P) INSTRUCOES DE MONTAGEM
(HR) UPUTE ZA MONTAZU
(RO) FOAIE CU INSTRUCIUNI
(BG) ИНСТРУКЦИИ ЗА СГЛОБЯВАНЕ

IMPORTANTE: Per evitare il ribaltamento accidentale del mobile è obbligatorio il fissaggio a muro. I tasselli necessari per il collegamento mobile/muro, dipendenti dal tipo di muro, non sono compresi. Consultare uno specialista in caso di dubbi.

IMPORTANT: To avoid the accidental tip-over of the furniture, the fixing of the furniture on the wall is mandatory. The needed hardware for the junction wall/furniture, depending of the nature of the wall, is not provided. If any doubt, consult a specialist.

IMPORTANT: Pour éviter le basculement accidentel du meuble, la fixation du meuble au mur est obligatoire. La visserie nécessaire pour la jonction mur/meuble, dépendante de la nature du mur n'est pas fournie. En cas de doute, consulter un spécialiste.

WICHTIG: Um die versehentliche Trübung der Möbel zu vermeiden, ist die Befestigung der Möbel an der Wand obligatorisch. Die benötigte Hardware für die Verbindungswand / Möbel, je nach Art der Wand, ist nicht vorgesehen. Wenn irgendwelche Zweifel, konsultieren Sie einen Spezialisten.

IMPORTANTE: Para evitar el vuelco accidental de los muebles, la fijación de los muebles en la pared es obligatoria. El hardware necesario para la pared / los muebles de la unión, dependiendo de la naturaleza de la pared, no se proporciona. En caso de duda, consulte a un especialista.

IMPORTANTE: Para evitar a queda accidental do mobiliário, a fixação dos móveis na parede é obrigatória. O hardware necessário para a junção parede / móveis, dependendo da natureza da parede, não é fornecido. Em caso de dúvida, consulte um especialista.

VAŽNO: Da bi se izbjeglo slučajno tip-over namještaja, fiksiranje namještaja na zidu je obavezno. Potreban hardver fot na spoj zida / namještaja, ovisno o prirodi zida, nije predviđeno. Ako imate bilo kakve sumnje, konzultirati stručnjaka.

VAŽNO: U CILJU IZBEGAVANJA SLUČAJNOG PREVRTANJA NAMEŠTAJA OBAVEZNO JE FIKSIRANJA ISTOG UZ ZID. NIJE PREDVIĐEN HARDVER FOT NA SPOJU ZIDA I NAMEŠTAJA. U SLUČAJU NEJASNOĆA POTREBNO JE KONSULTOVATI STRUČNO LICE.

OPOZORILO:

Da ne bi pohištva prevrnili, je pritrđitev pohištva na steno obvezna.

Deli, potrebni za pritrđitev pohištva na steno, ki so odvisni od vrste stene, niso priloženi.

Če ste v dvomih, se posvetujte s strokovnjakom.

Важно:

За да избегнете случайно преобръщане на мебелите, те трябва да бъдат фиксирани към стената.

Не са включени дюбелите, необходими за прикрепването на мебелите към стената в зависимост от нейния вид.

При въпроси и съмнения се консултирайте със специалист!

IMPORTANT: Pentru a evita rasturnarea accidentala a mobilierului, fixarea pe perete este obligatorie. Mufele necesare pentru racordarea dulap/perete, in functie de tipul de perete, nu sunt incluse. Consultați un specialist dacă aveți dubii.

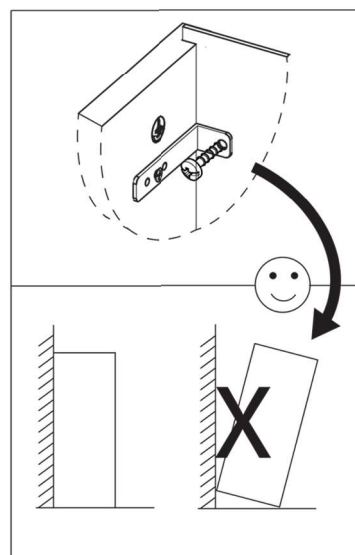

ARES

(IT) ISTRUZIONI DI MONTAGGIO
(GB) ASSEMBLING INSTRUCTIONS
(FR) NOTICE DE MONTAGE
(SLO) NAVODILA ZA MONTAŽO
(SRB) UPUTSTVO ZA MONTAŽU

(D) MONTAGEANLEITUNG
(ES) INSTRUCCIONES DE MONTAJE
(P) INSTRUCOES DE MONTAGEM
(HR) UPUTE ZA MONTAZU
(RO) FOAIE CU INSTRUCIUNI
(BG) ИНСТРУКЦИИ ЗА СГЛОБЯВАНЕ

| | Cod. | Parcel number | Size - mm. | Description | n. |
|----|----------------|----------------|------------|-------------|----|
| 1 | 8WEBEFF002S | 8WEBEFF002S | | FRIDGE | 1 |
| 2 | 8WEPAKEX6002NE | 8WEPAKEX6002NE | | HOOD | 1 |
| 3 | 8WEBEPC006 | 8WEBEPC006 | | HOB | 1 |
| 4 | 8WXXLXO791S | 8WXXLXO791S | | SINK | 1 |
| 5 | 8WEBEFO005N | 8WEBEFO005N | | OVEN | 1 |
| 15 | 8WEBELV001 | 8WEBELV001 | | DISHWASHER | 1 |

| | Cod. | Parcel number | Size - mm. | Fridge column | n. |
|-----|---------------|---------------|-------------|------------------------|----|
| 1-6 | 4WKTBI3CA004 | 2WASBI6035 | 563X531X18 | TOP | 3 |
| 2-6 | 4WKTBI1BA004 | 2WASBI6035 | 563X531X18 | BOTTOM | 1 |
| 3-6 | PWXXBI3FD501 | 2WKTBI6741 | 2040X560X18 | RH SIDE | 2 |
| 4-6 | PWXXBI3FS501 | 2WKTBI6741 | 2040X560X18 | LH SIDE | 2 |
| 5-6 | 9WIRGS7SP804D | 2WIRGS6050D | 596X1316X18 | DOOR | 1 |
| 6-6 | 9WIRGS7SP604D | 2WIRGS6050D | 596X716X18 | DOOR | 1 |
| 7-6 | 5MRBA2013 | 2WKTBI6741 | 333X578X3 | BACK | 1 |
| 8-6 | 5MRBA2025 | 2WKTBI6741 | 210X150X3 | BACK | 1 |
| 9-6 | 9WXXAPFA601 | 9WXXAPFA601 | | UNDER FRIDGE PROTECTOR | 1 |

| | Cod. | Parcel number | Size - mm. | | n. |
|---|-----------------|---------------|-------------|-----|----|
| 7 | 4WBRKZTBB2264KZ | 2WBRKZTBB2264 | 2252X600X38 | TOP | 1 |

| | Cod. | Parcel number | Size - mm. | | n. |
|---|----------------|----------------|------------|---------------------|----|
| 8 | 2WIRBIPP457GSD | 2WIRBIPP457GSD | | WALL UNIT L.45 H.72 | 1 |
| 9 | 2WIRBIPP607GSS | 2WIRBIPP607GSS | | WALL UNIT L.60 H.72 | 2 |

| | Cod. | Parcel number | Size - mm. | Sink cabinet | n. |
|------|---------------|---------------|------------|----------------------|----|
| 3-10 | 4WKTBI1BA003 | 2WMMBI6101 | 413X531X18 | BOTTOM | 1 |
| 2-10 | 4WXXBI1FI201 | 2WMMBI6101 | 720X560X18 | LH-RH SIDE | 2 |
| 1-10 | 9WIRGS7SP603S | 2WIRGS7128S | 447X717X19 | DOOR | 1 |
| 4-10 | 9WXXNC1FA123 | 2WMMBI6101 | 413X67X18 | JOIN CHAIN | 3 |
| 5-10 | 9WXXAPLA601 | 9WXXAPLA601 | | UNDER SINK PROTECTOR | 1 |

| | Cod. | Parcel number | Size - mm. | | n. |
|----|-----------------|-----------------|------------|--------------------------|----|
| 11 | 2WIRBIBF607GS | 2WIRBIBF607GS | | OVEN UNIT | 1 |
| 12 | 2WGGBIBCS457GSD | 2WGGBIBCS457GSD | | 2 DRAWERS CHEST -1 DOORS | 1 |
| 13 | 8WXXZAK501 | 8WXXZAK501 | | PLINT | 1 |
| 14 | 2WIRGSJSL406 | 2WIRGSJSL406 | | DISHWASHER DOOR | 1 |

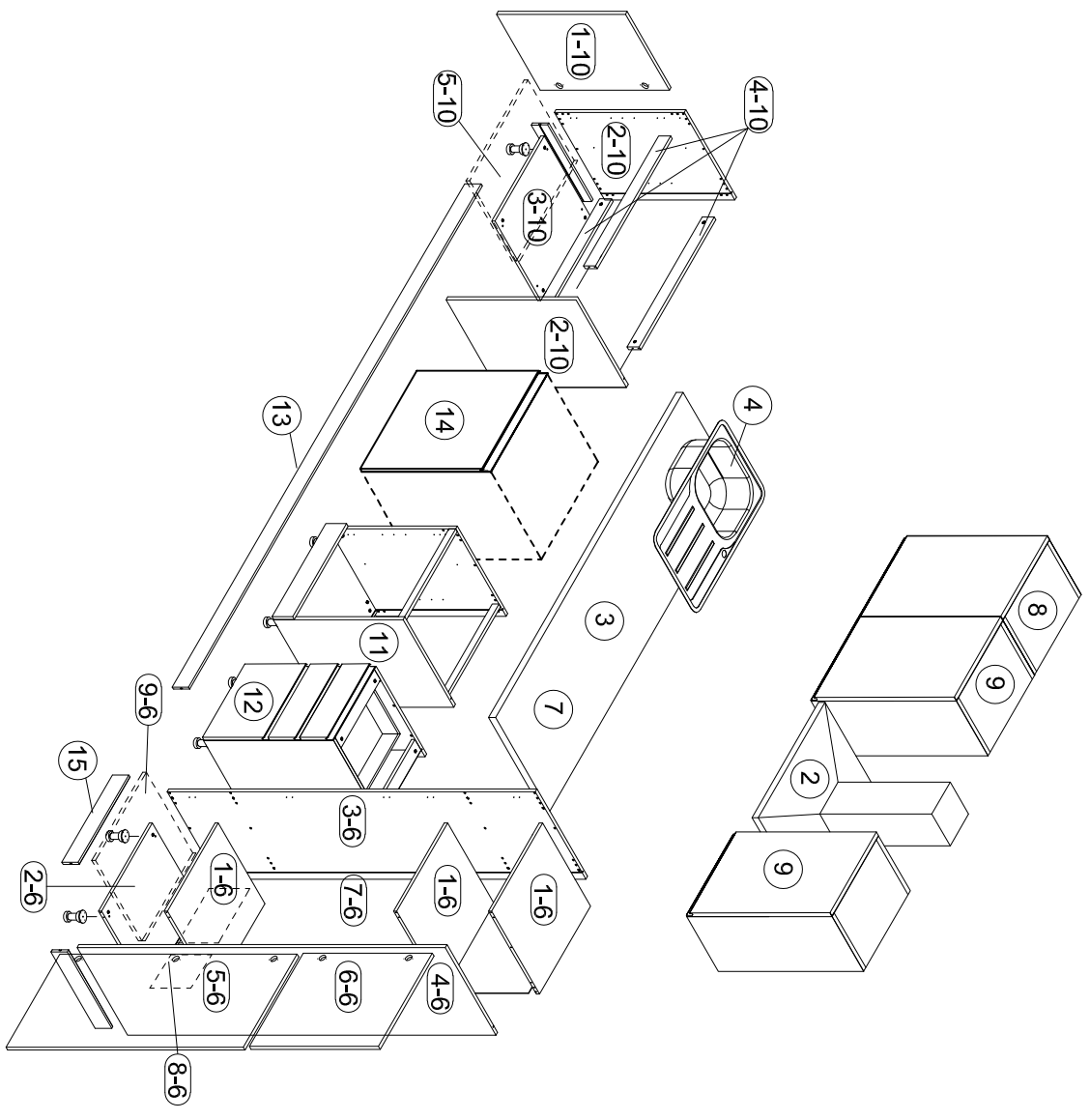

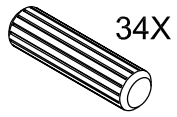

5SIFA2000



FFMON2065

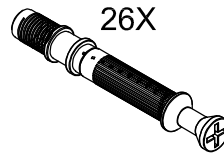

FFMON2083

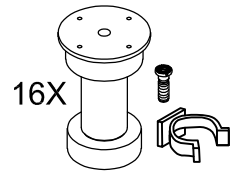

8WXXAPBN01



FFCOL2000

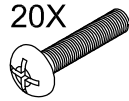

FFVAN2018
4MAX22



FFVAN2056
3.5X15

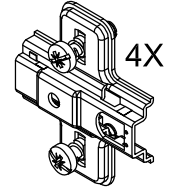

FFBMP2020

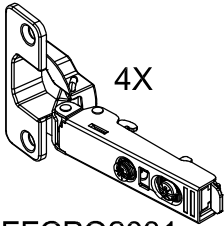

FFCPO2031

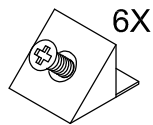

FFFSZ2007

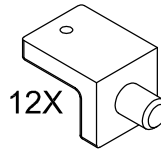

FFFPC2004

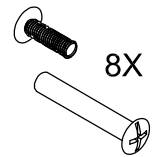

FFGPN2226

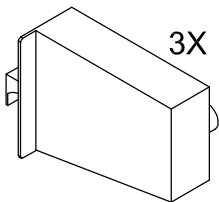

Z-ATTA01

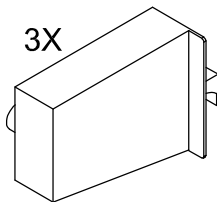

Z-ATTA02

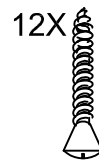

FFVAN2050
4x25

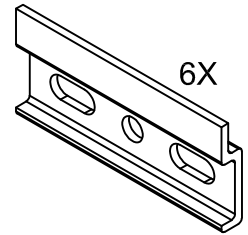

FFBAR5007

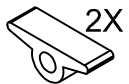

FFRPN2014

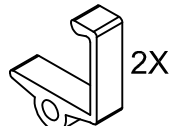

FFRPN2015



FFRPN2016

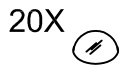

FFPAR1050

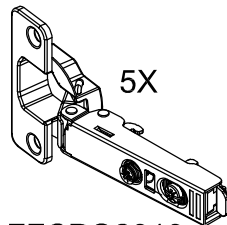

FFCPO2010

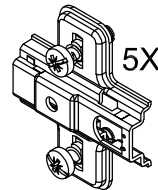

FFBMP2007

12 ^{NR}

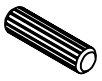

5SIFA2000

10 ^{NR}



FFMON2065

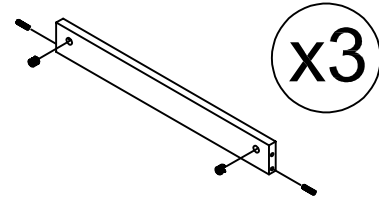
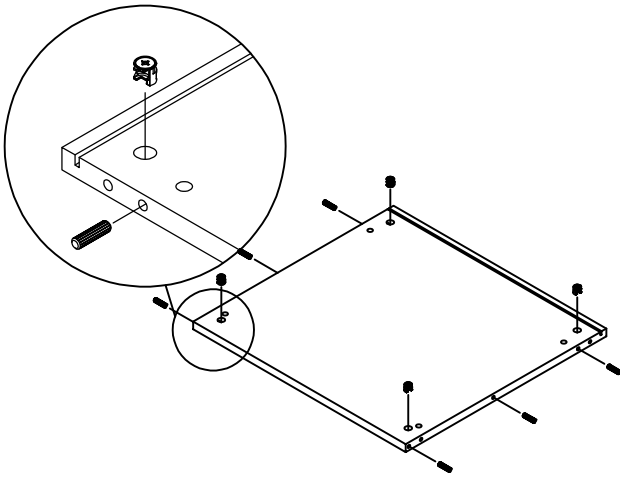

8 ^{NR}

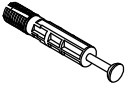

FFMON2051

2 ^{NR}

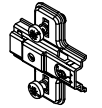

FFBMP2020

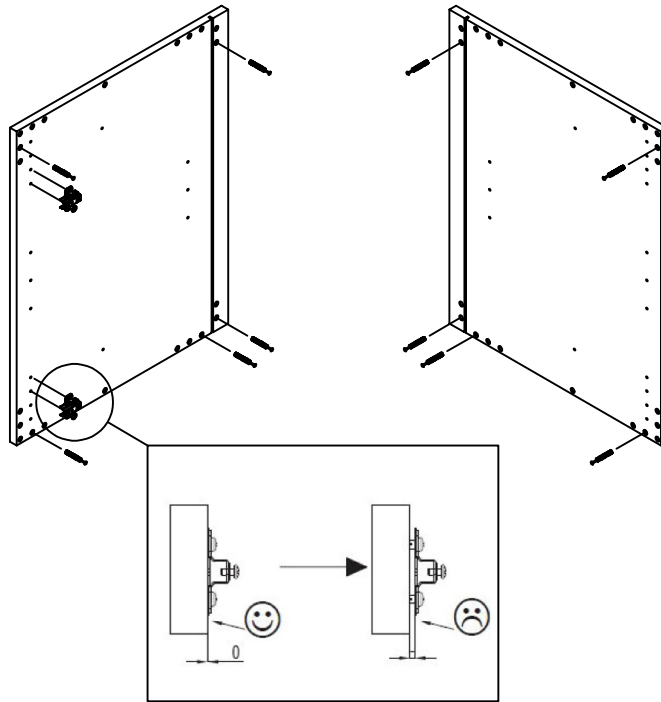

4 ^{NR}



8WXXAPBN01

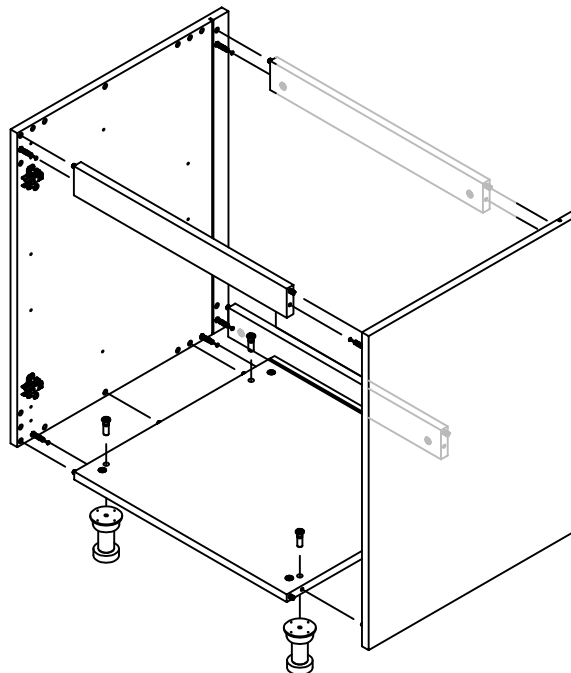

4 ^{NR}



FFVAN2056
3.5X15

2 ^{NR}

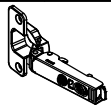

FFCPO2031

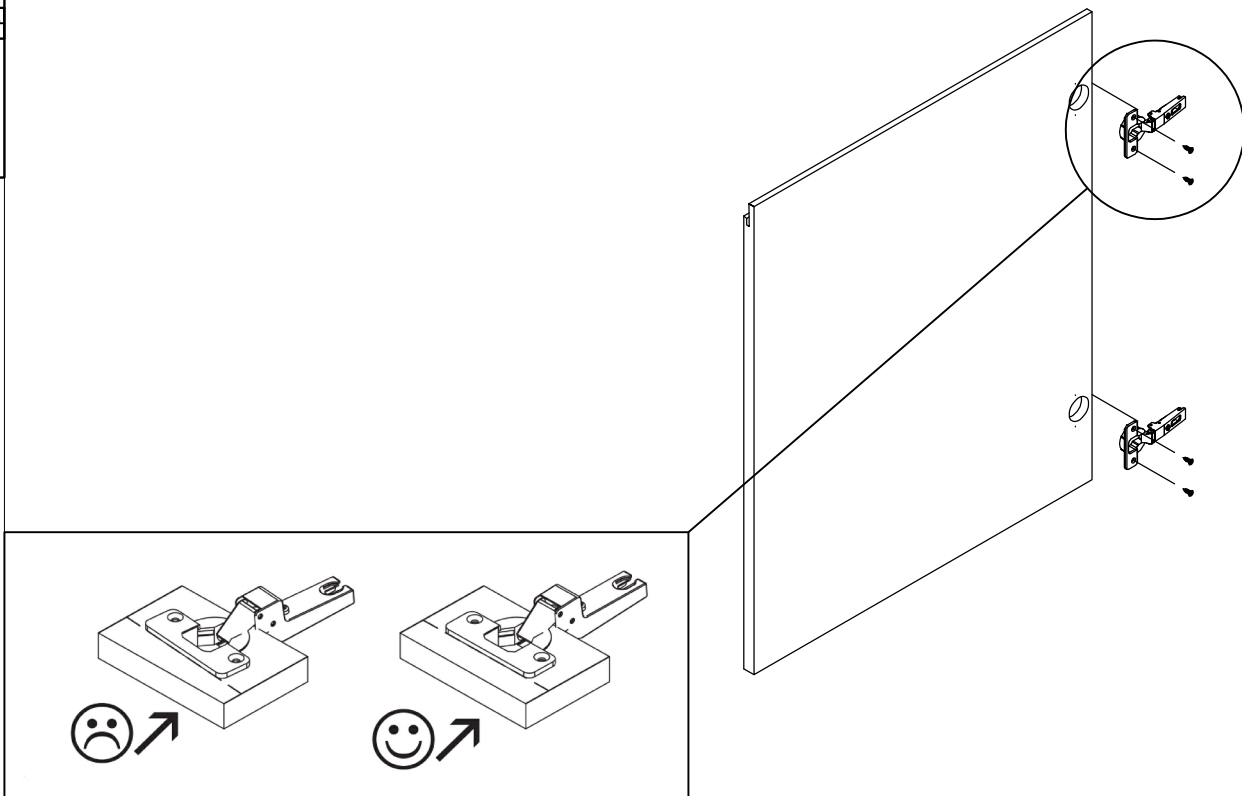

2 ^{NR}



FFPAR1050

2 ^{NR}



9WXXAPLA601

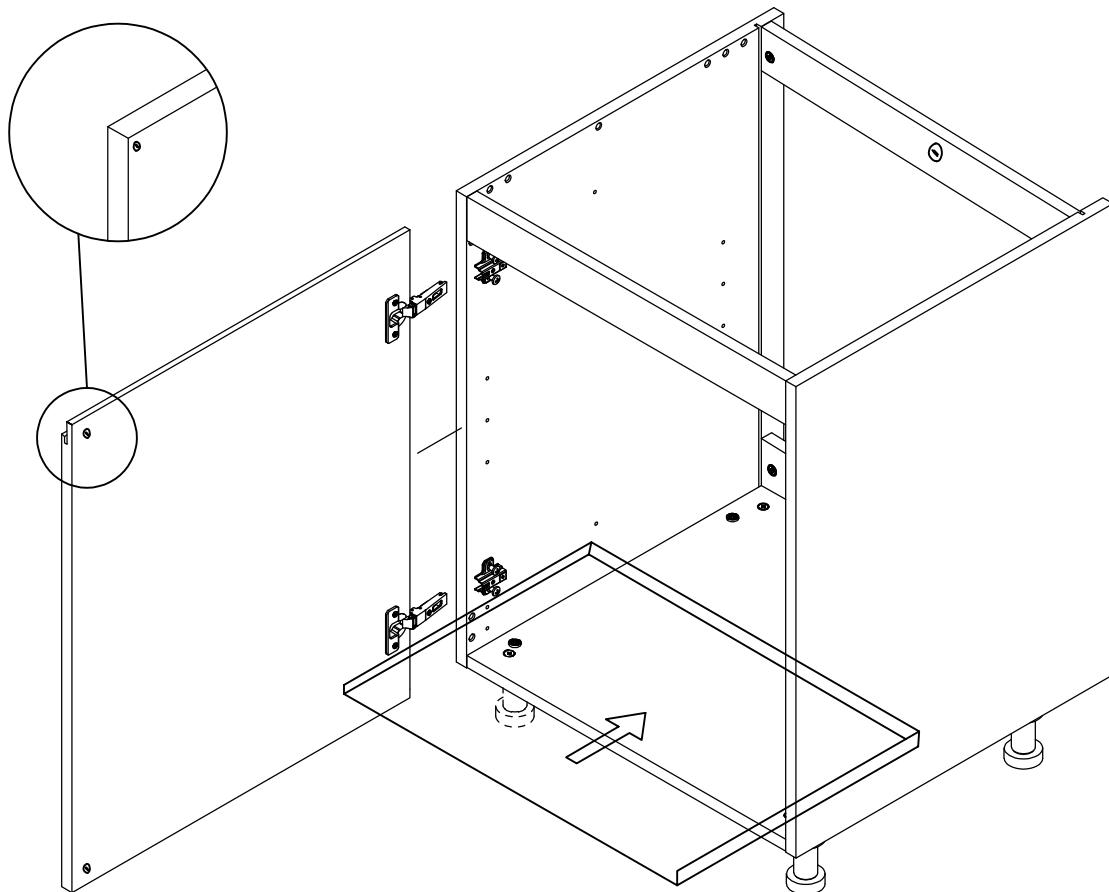
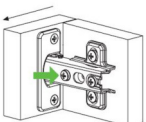
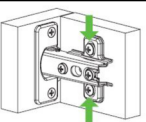
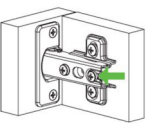

4 INR



FFMON2065

6 INR

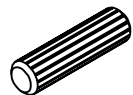

5SIFA2000

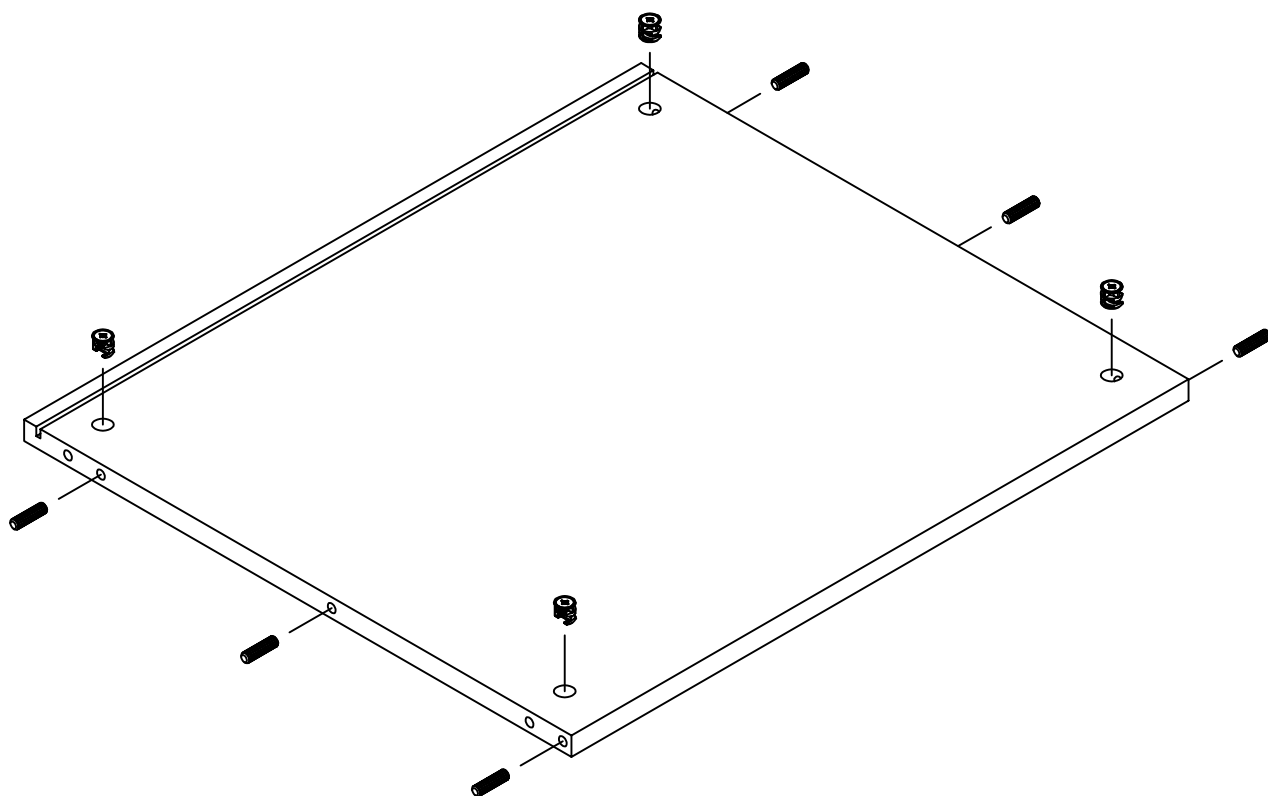

4 INR



FFMON2065

6 INR

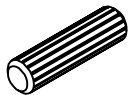

5SIFA2000

X2

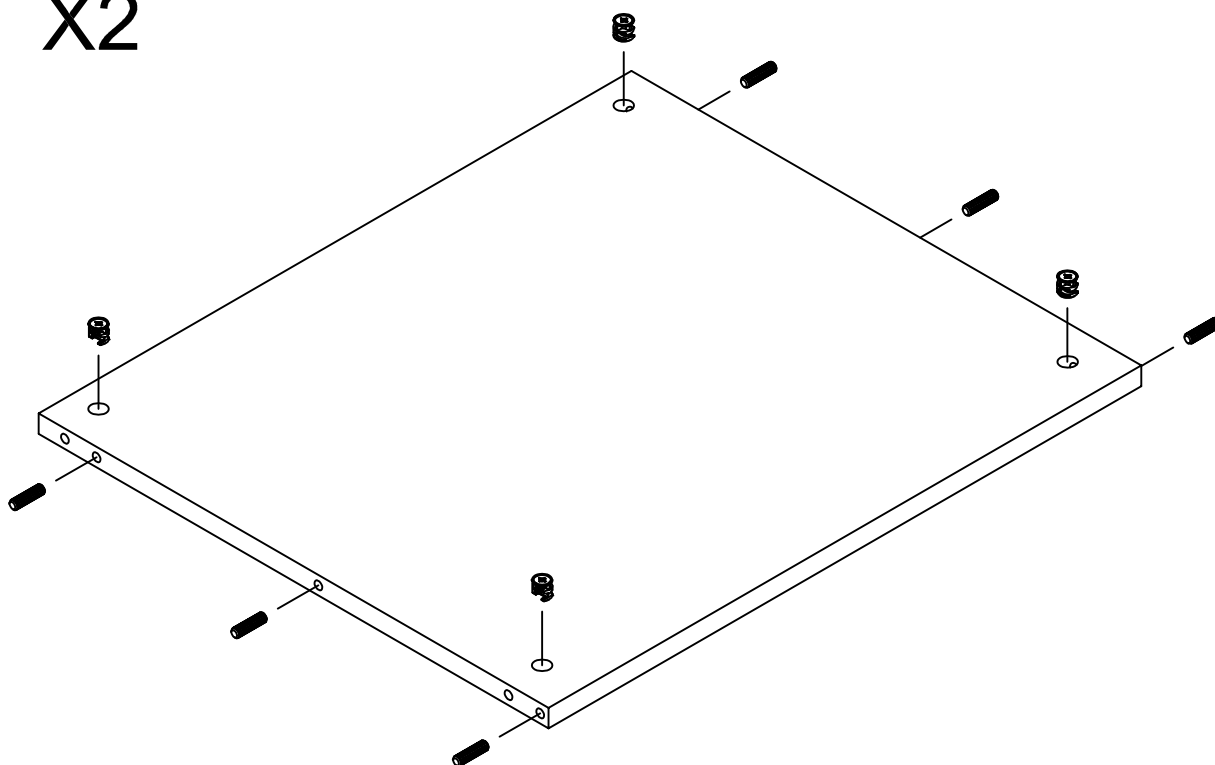

4 INR



FFMON2065

6 INR

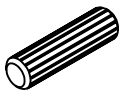

5SIFA2000

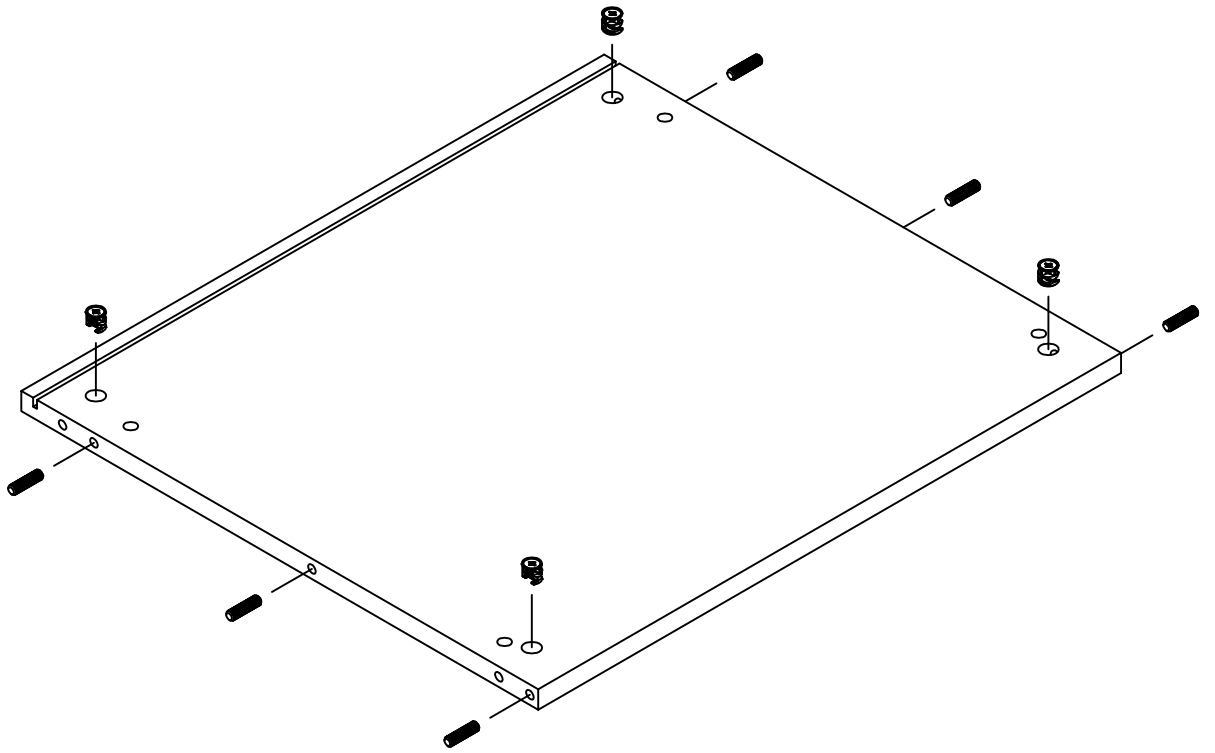

16 INR



FFMON2083

5 INR

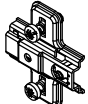

FFBMP2007

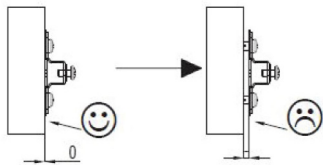
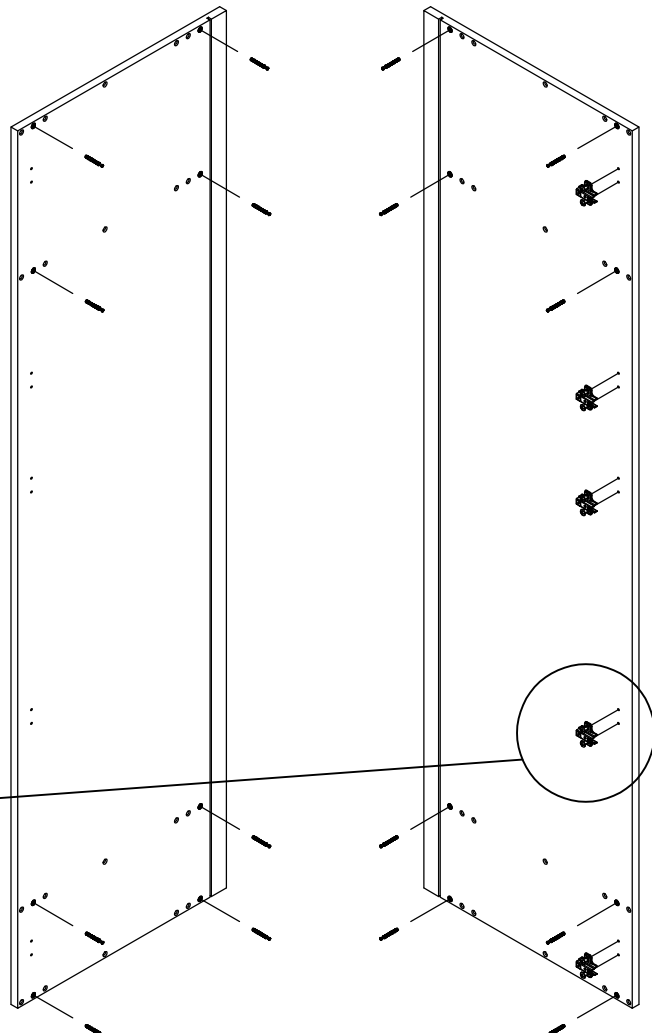

4 INR

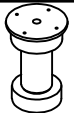

8WXXAPBN01

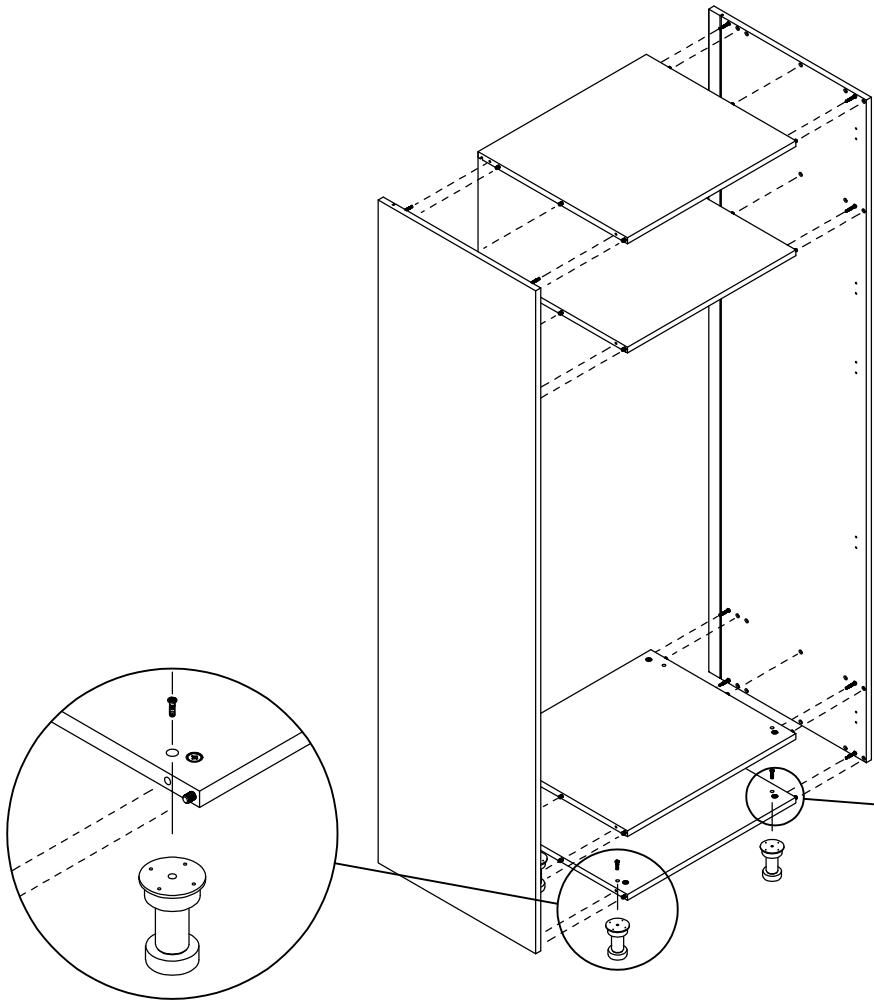

6 INR



FFFSZ2007

2 INR



8SPFE4146

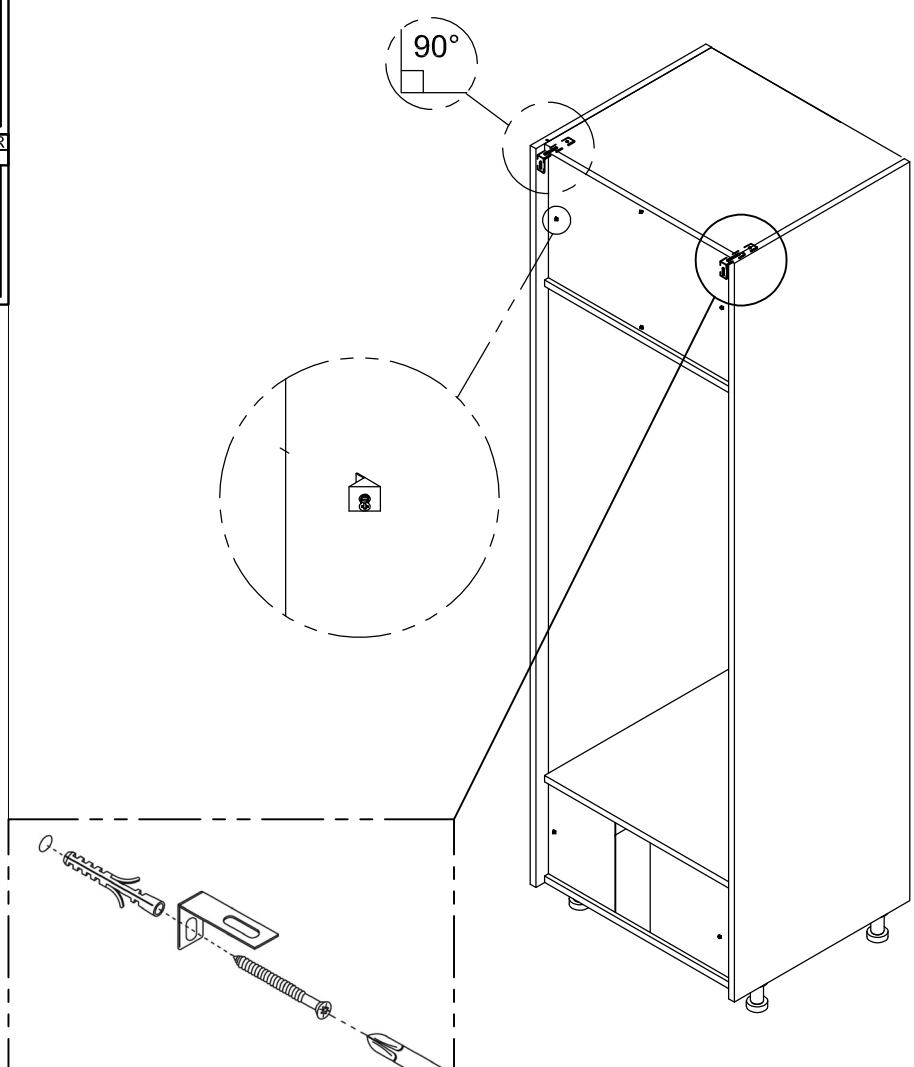

5 NR

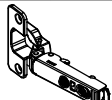

FFCPO2010

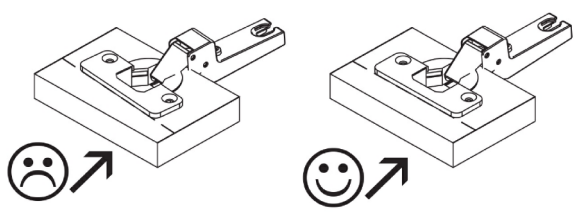
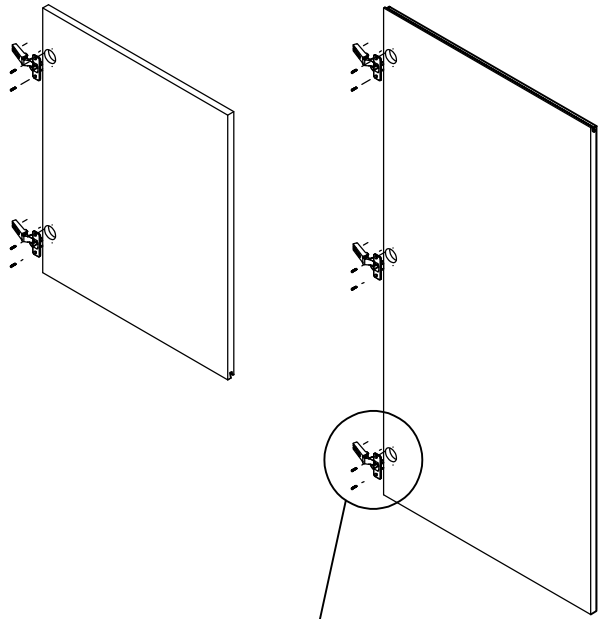

4 NR



FFPAR1050

1 NR

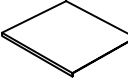

9WXXAPFA601

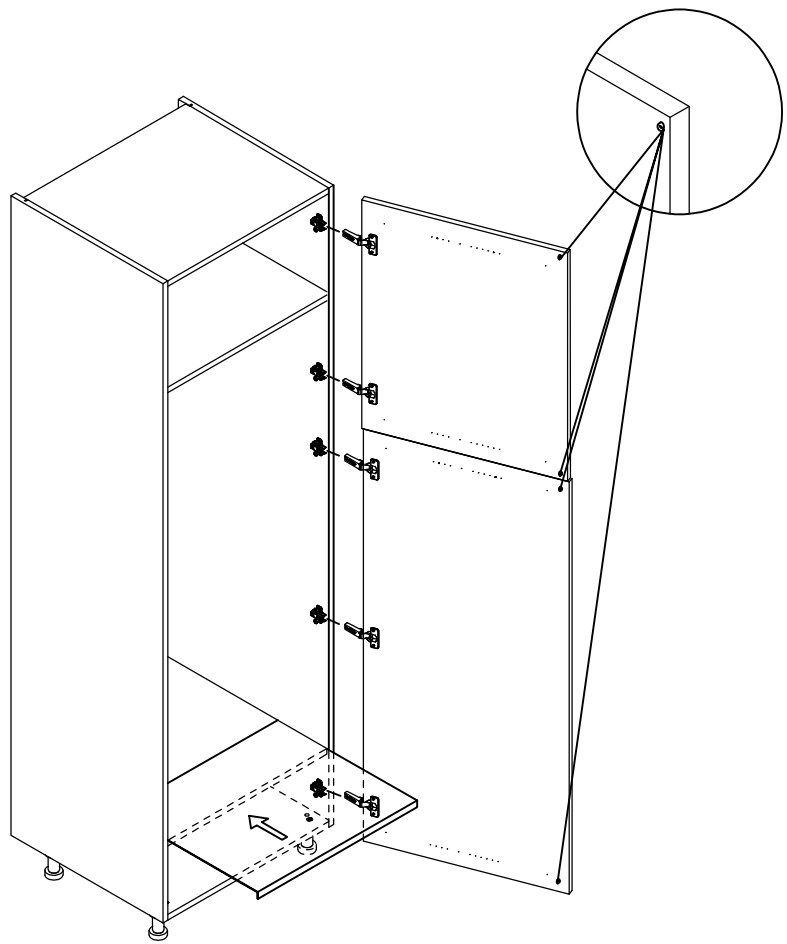

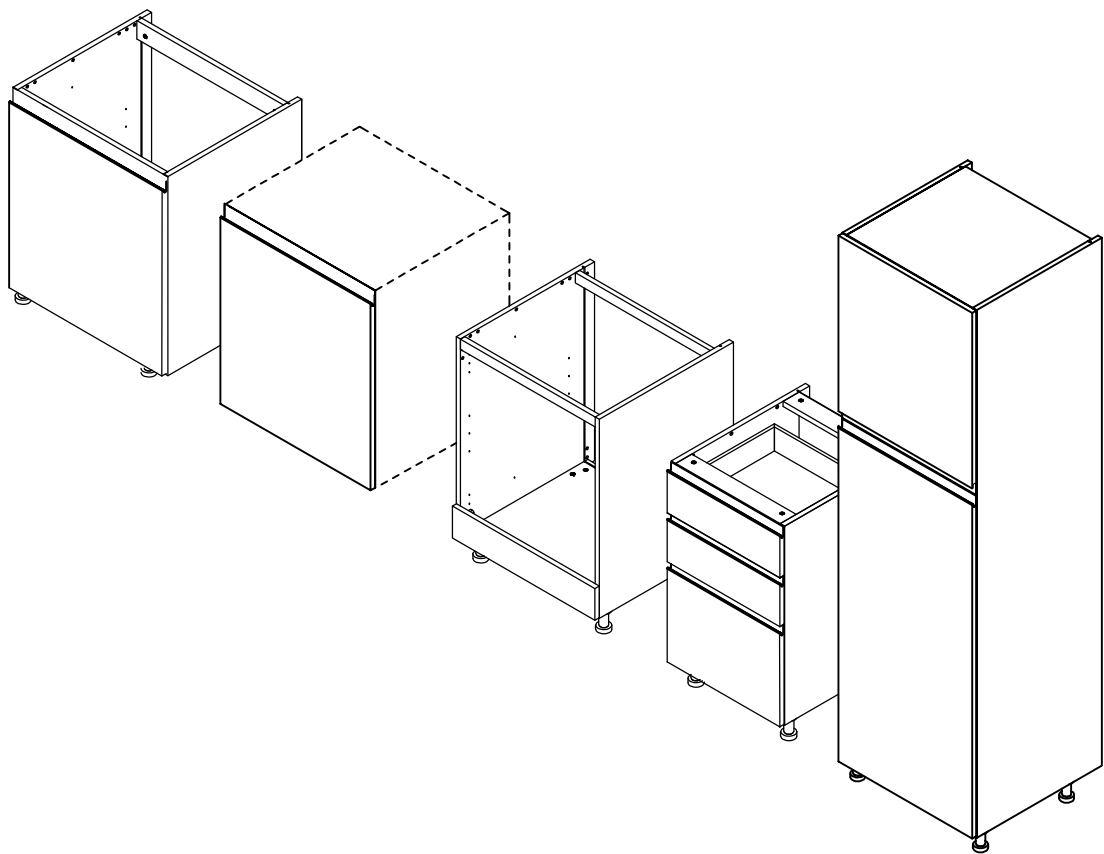

X 8 ^{NR}

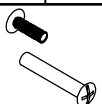

FFGPN2226

X 16 ^{NR}

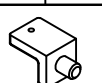

FFFPC2004

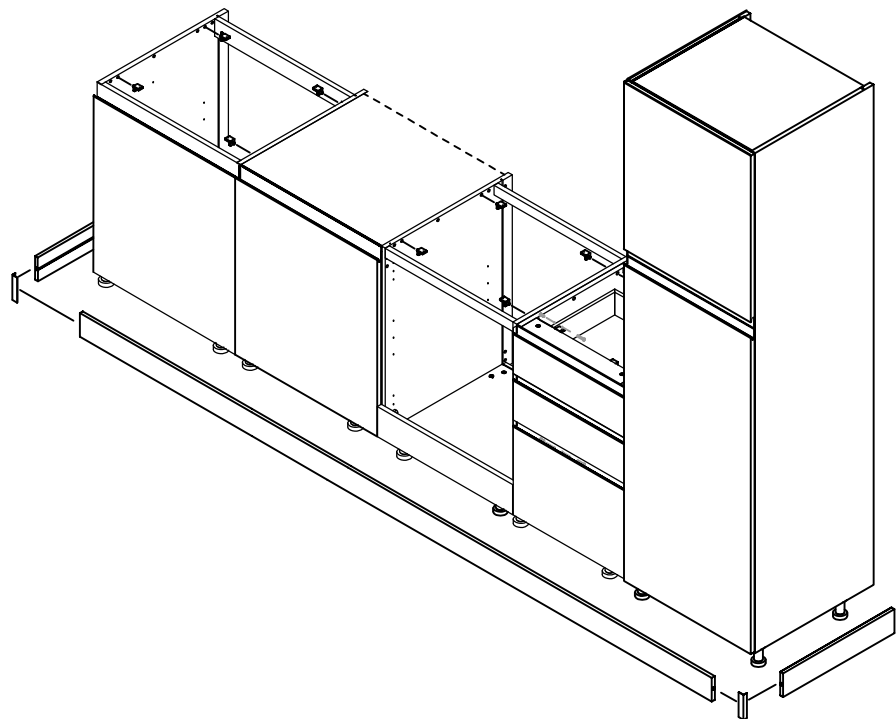
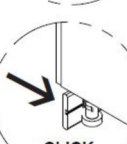
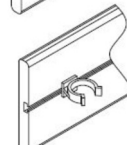
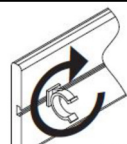

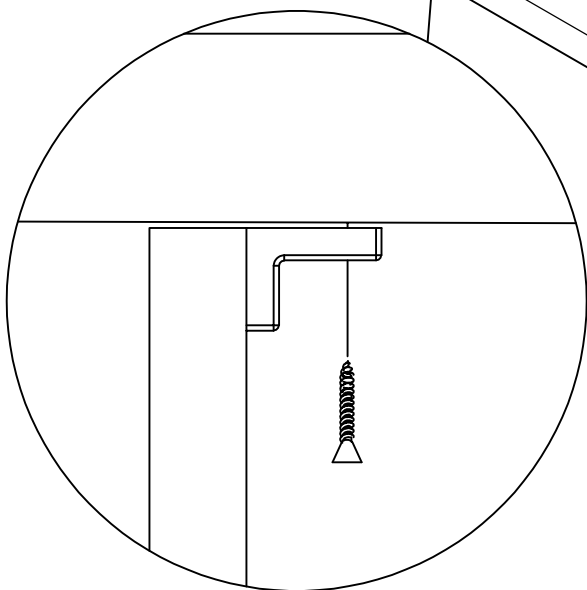
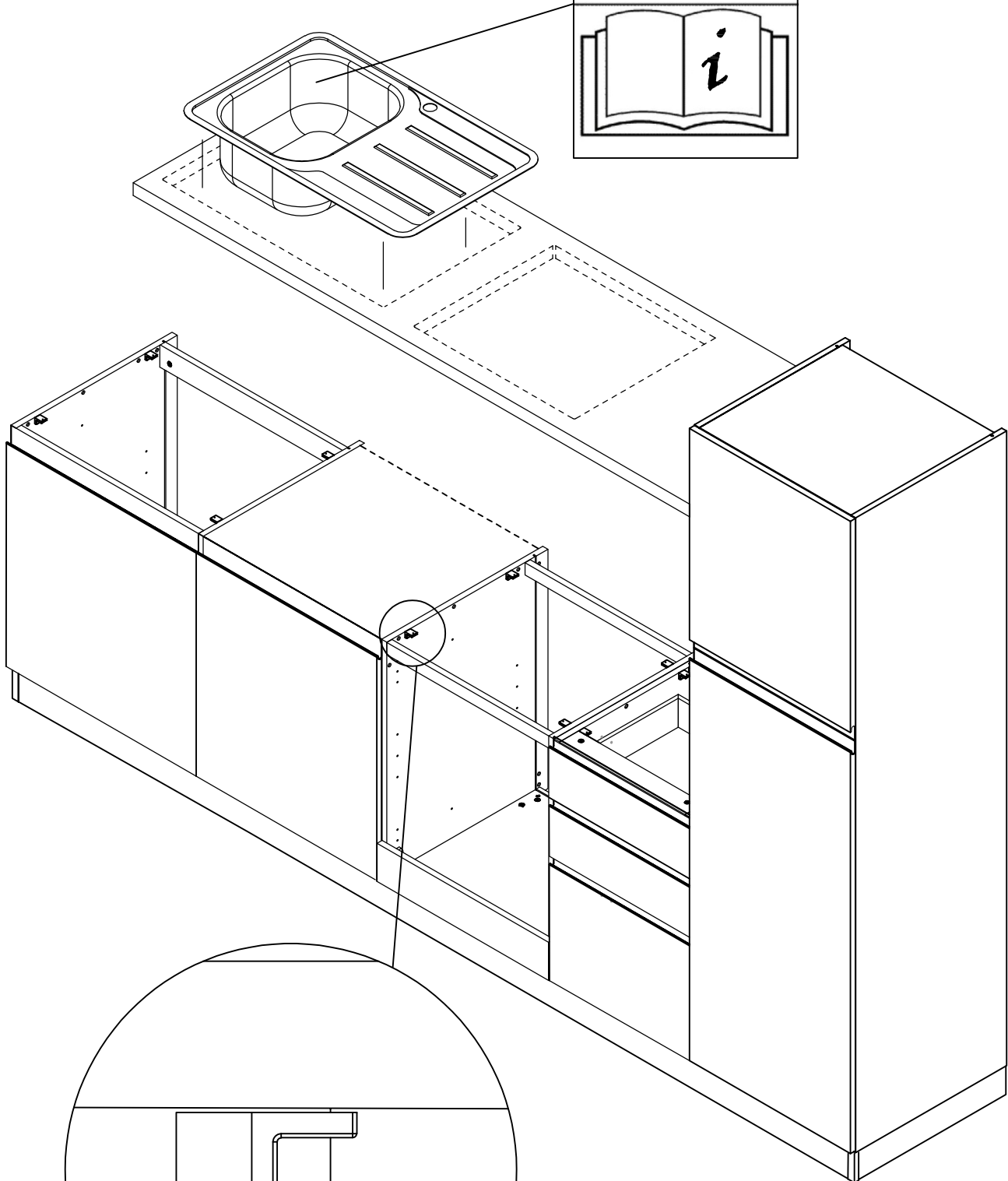
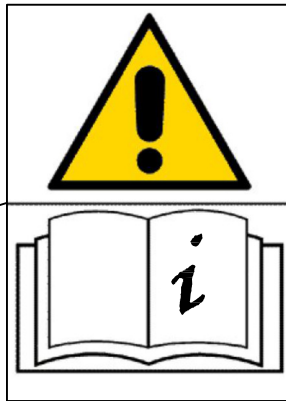

FFVAN2050
4x25

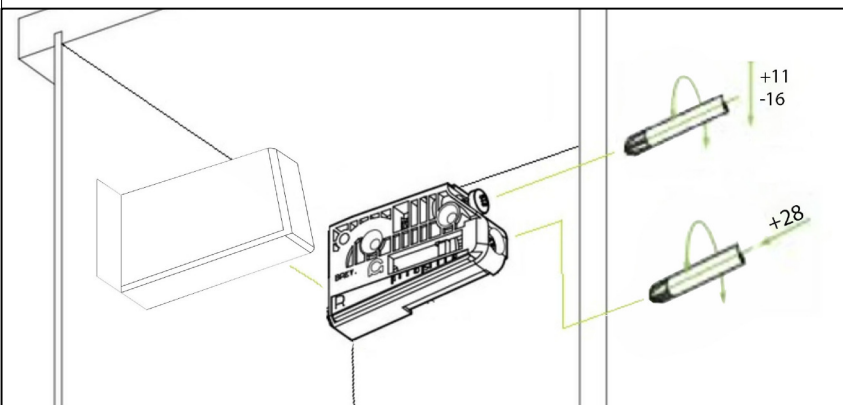
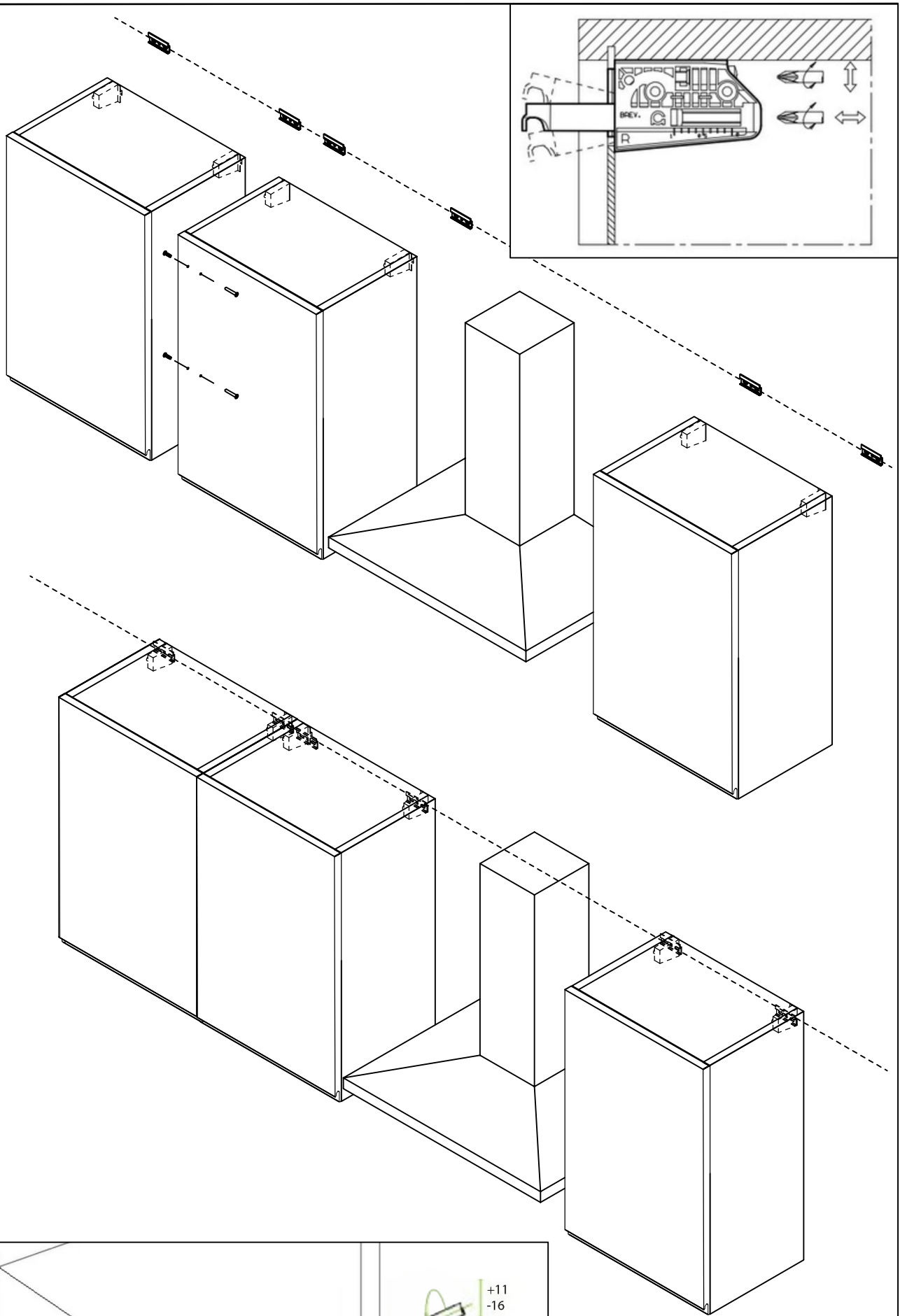

- X 2 ^{NR}
FFGPN2226
- X 6 ^{NR}
FFBAR5007
- X 3 ^{NR}
Z-ATTA02
- X 3 ^{NR}
Z-ATTA01

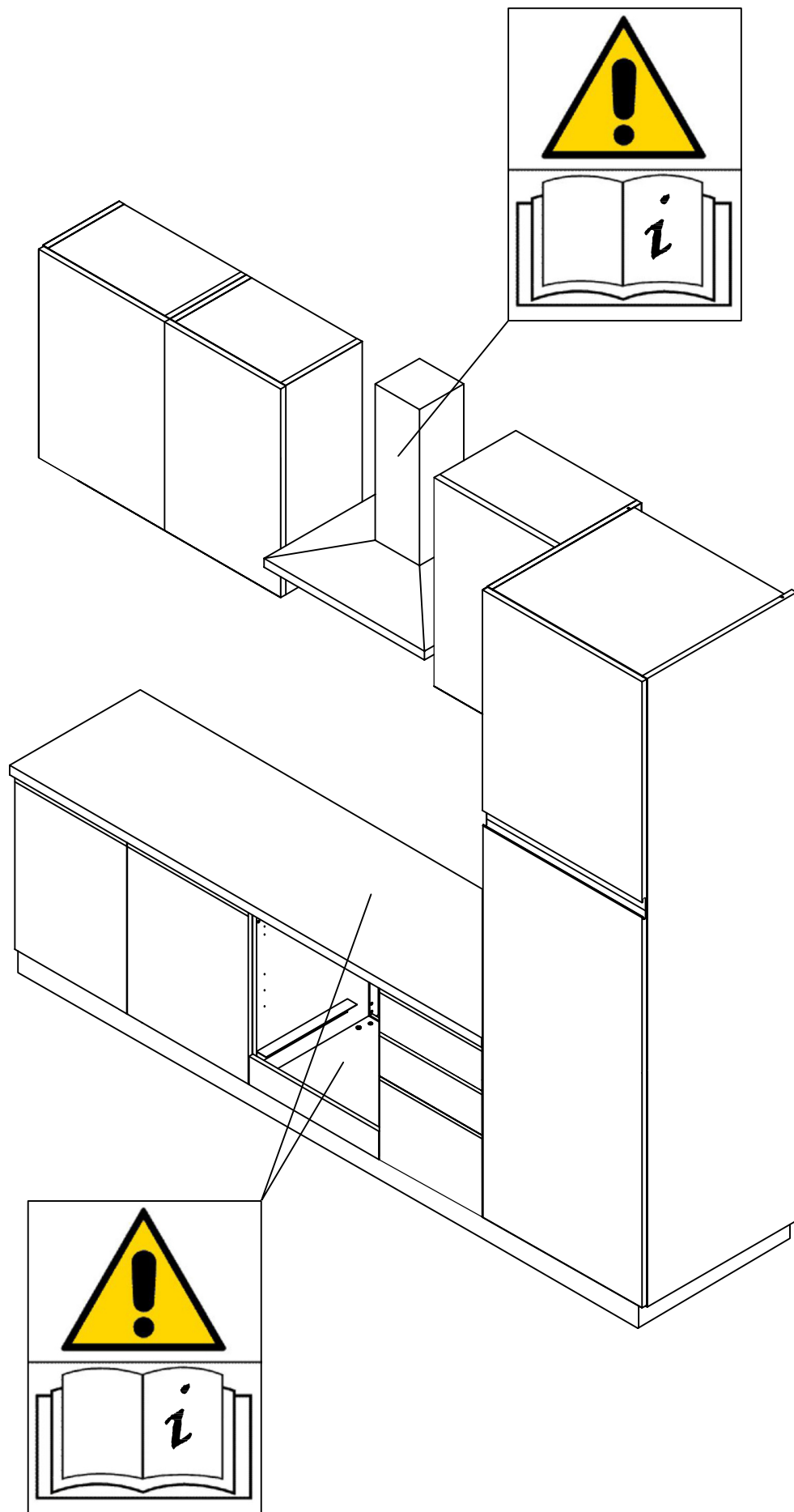



Beko

- **Romania** (Centru de asistență): <https://www.beko.com/ro-ro/support/contact>
- **Croazia** (Korisnička podrška): <https://www.beko.com/hr-hr/support/help-center>
- **Serbia** (Korisnička podrška / Servisni centar): <https://www.beko.com/rs-sr/PodrSka/obratite-nam-se>