

# ARES

IT ISTRUZIONI DI MONTAGGIO  
GB ASSEMBLING INSTRUCTIONS  
FR NOTICE DE MONTAGE  
SLO NAVODILA ZA MONTAŽO  
SRB UPUTSTVO ZA MONTAŽU

D MONTAGEANLEITUNG  
ES INSTRUCCIONES DE MONTAJE  
P INSTRUÇÕES DE MONTAGEM  
HR UPUTE ZA MONTAZU  
RO FOAIE CU INSTRUCȚIUNI  
BG ИНСТРУКЦИИ ЗА СГЛОБЯВАНЕ

COD.0WMLN021DWPWPWP

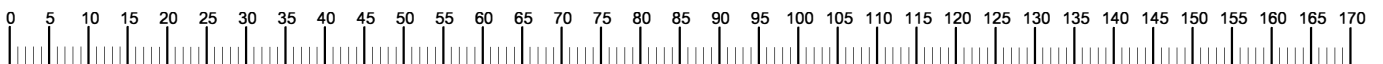
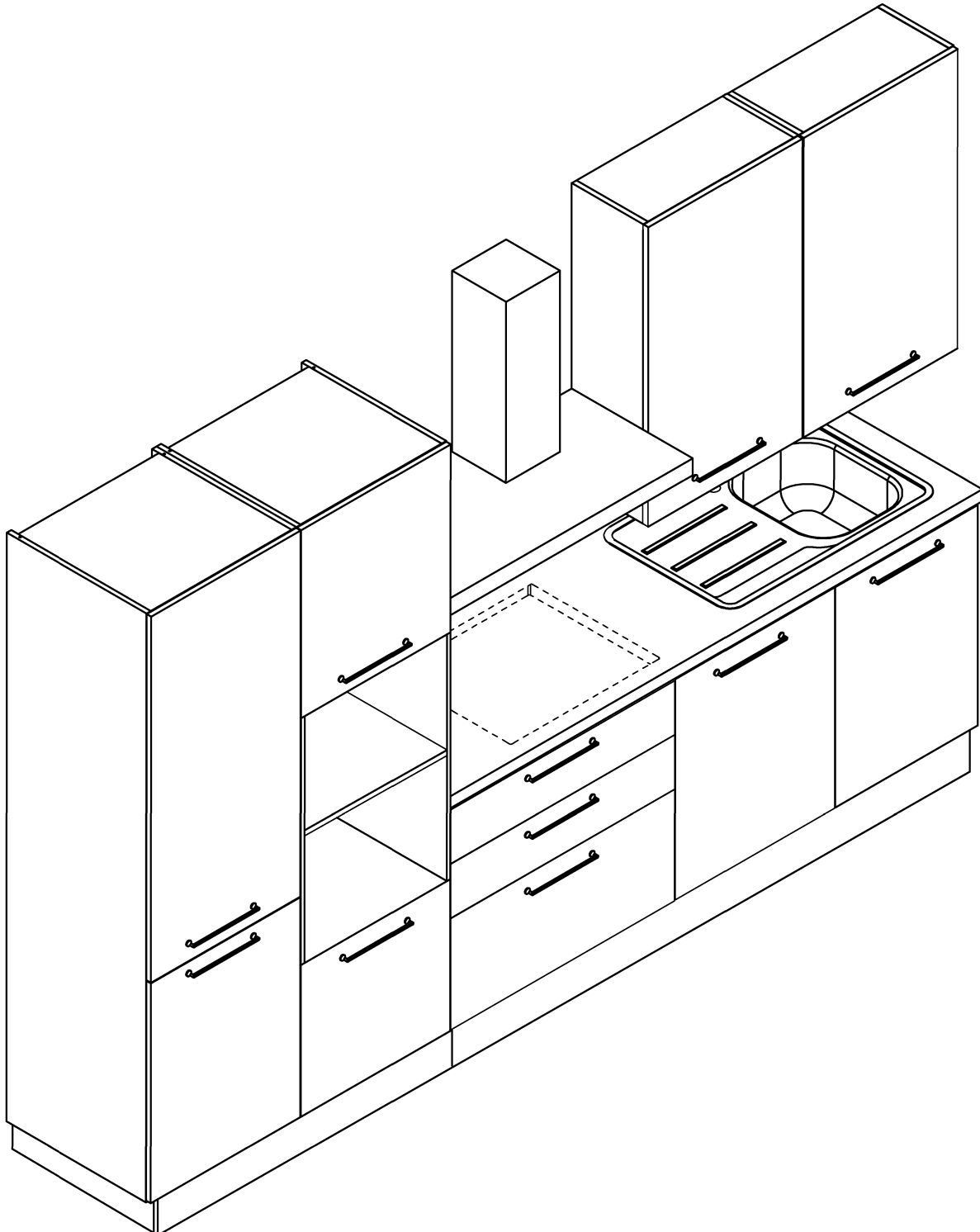
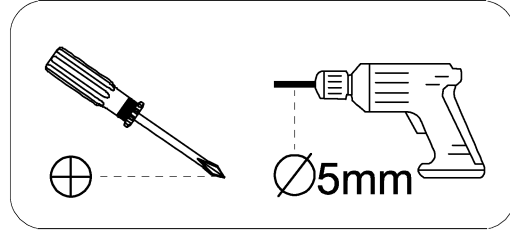
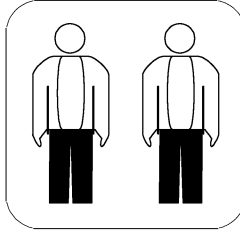
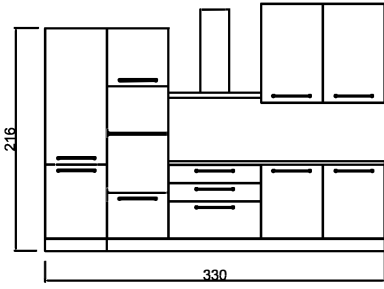

## Française – Suisse

### CONSEILS DE MONTAGE

1. Bien étudier la notice de montage;
2. Repérez les pièces constituant votre meuble;
3. Regroupez et contrôlez la quincaillerie;
4. Munissez-vous de l'outillage nécessaire;
5. Aménagez-vous une zone de montage;
6. Procédez au montage.

### CONSEILS D'ENTRETIEN

1. Dépoussiérez soigneusement;
2. Humecter un chiffon doux et propre d'eau légèrement savonneuse (ou détergent)

Ne jamais forcer les assemblages  
Resserrez les vis après quelques temps d'usage  
Garder votre notice de montage  
Si une pièce devait a manquer, le plus simple est de contacter votre magasin directement  
Le poids maximum autorisé sur les boîtes de tiroir est de 10 kg

Ne jamais utiliser de produits abrasifs:  
poudre, laine d'acier, solvants

## English

### ASSEMBLING ADVICE

1. Study careful the assembly instructions;
2. Characterize pieces that form the furniture;
3. Group and control the ironware;
4. Take the necessary tools for the assembly;
5. Prepare an assembly zone;
6. Proceed with the assembly.

### MAINTENANCE ADVICE

1. Dust accurately;
2. Damp a cleaned and soft cloth with water and little detergent.

Never force the assemblages  
Screw the screws after a long period  
Conserve the assembly instructions  
If one or more pieces are missing, please contact the store  
Maximum weight allowed on drawer boxes is 10kg.

Do not use abrasive products: powder, steel wool, solvents

## Italiano – Svizzera

### CONSIGLI DI MONTAGGIO

1. Studiare bene le istruzioni di montaggio;
2. Controllare che tutti i pezzi che costituiscono il mobile siano presenti;
3. Raggruppare e controllare la ferramenta;
4. Munirsi degli utensili necessari al montaggio;
5. Allestire una zona di montaggio;
6. Procedere al montaggio.

### CONSIGLI PER LA MANUTENZIONE

1. Spolverare accuratamente;
2. Inumidire con acqua leggermente insaponata uno straccio morbido e pulito.

Non forzare mai gli assemblaggi  
Stringere le viti dopo un periodo d'uso  
Conservare le istruzioni di montaggio  
Se un pezzo dovesse mancare o essere rotto, contattare il punto vendita  
Il peso massima supportato dai cassetti è di 10kg.

Non utilizzare mai prodotti abrasivi:  
polvere, lana di acciaio, solventi

## Deutsch – Schweiz

### MONTAGE ANLEITUNG

1. Die Montageanleitung genau durchlesen;
2. Die Einzelteile des Möbels stück ermitteln;
3. Die Beschläge zusammenlegen und prüfen;
4. Das Notwendige werkzeug zurechtlegen;
5. Einem Montagebereich freimachen;
6. Das Möbels stück zusammenbauen.

### PFLEGEHINWEISE

1. Sorgfältig entstauben;
2. Mit einem weichen, sauberen und feuchtem Tuch und leichter selfentaue reinigen

Niemals die Verbindungen zu stark anziehen  
Die Schrauben nach Lang Zeit des Gebrauchs erneut festziehen  
Die Montageanleitung gut aufbewahren  
Wenn ein Teil fehlen, ist Sie das beste Verständigungsmittel mit Ihrem Geschäft  
Das maximale Gewicht auf Schubladenkästen erlaubt ist 10 kg

Benutzen Sie keine Scheuermittel wie  
Pulver, Stahlwolle, Lösungsmittel

## Español

### CONSEJOS PARA EL MONATJE

1. Estudie atentamente el manual de montaje;
2. Localice las piezas que constituyen su mueble;
3. Reuna y contrle los tornillos;
4. Equipese de las herramientas necesarias;
5. Prepare una zona de montaje;
6. Realice el montaje.

### CONSEJOS PARA EL MANTENIMIENTO

1. Despolvorear cuidadosamente;
2. Humedecer un pano suave y limpio con agua ligeramente enjabonada.



No fuerce nunca en las uniones  
Apriete los tornillos despues de cierto tiempo de utilizacion  
Conserve su manual de montaje  
Si faltara una pieza, seia la manera mas facil de comunicar con la tienda  
El peso máximo permitido en las cajas de cajón es de 10 kg

No use nunca productos abrasivos tales como: polvo de limpiar, lana de acero, solventes.

## Portugues

### CONSELHOS DE MONATAGEM

1. Estuda bem as instruções de montagem;
2. Junta as peças que constituem o seu móvel;
3. Reagrupa e controla a quinquilharia;
4. Equipa-se da ferramenta necessária;
5. Cria-se uma zona de montagem;
6. Proceda á montagem.

### CONSELHOS DE MONTAGEM

1. Eliminar bem o po;
2. Umedecer um pano suave e limpo con agua e um pouco de sabao.



Nunca esforçar as montagem  
Apertar os pafusos após un tempo de utilização  
Guardar as instruções de montagem, si faltara alguna pieza, lo mas aconsejable es contactar con la tienda  
O peso máximo permitido em caixas de gaveta é de 10 kg

Nunca utilizar productos abrasivos pos, la de aço, solventes

## Hrvatski

### SAVJETI ZA MONTAZU

1. Porucite pazljivo upute za montazu;
2. Prekontrolirajte po uputama da li imate sve dijelove;
3. Prekontrolirajte da li imate sve vijke, matice i ostale metalne dijelove;
4. Osigurajte potreban alat za sastavljanje;
5. Oslobodite odgovarajuci prostor za montiranje;
6. Ukoliko ste provjerili sve gore navedeno mozete zapoceti montazu.

### SAVJETI ZA ODRZAVANJE

1. Uklanjajte redivito prasinu i necistoce;
2. Cistite uvijek s mlo vode i blagog deterdzenta te mekom i cistom krpom.



Prilikom montiranja, nemojte nasilno pokušavati spojiti dijelove  
Odvijati vijke nakon duzeg stajanja montiranog proizvod  
Ukoliko Vam nedostaje koji dio, molimo Vas kontaktirajte trgovinu u kojoj ste namjestaj kupili  
Ladica ima nosivost od maksimalnih 10kg

Nemojte koristiti abrazivne krpe, pudere, matalnu vunu ili sredstva koja mogu otopiti površinu namjestaja

## SLOVENŠČINA

### NAVODILA ZA MONTAŽO

1. Pozorno preberite navodila za montažo;
2. Določite posamezne dele pohištva;
3. Preverite, ali imate vse vijake, matice in ostale kovinske dele;
4. Pripravite potrebna orodja;
5. Pripravite in počistite prostor, kjer boste pohištvo sestavljali;
6. Sestavite pohištvo.

### NAVODILA ZA NEGO

1. Redno brišite prah.
2. Očistite z mehko, čisto in vlažno krpo ter uporabite malo milnice.



Delov ne zategujte preveč.  
Po daljšem času ponovno zategnite vijake.  
Navodila za montažo hranite na varnem mestu.  
Če kakšen del manjka, kontaktirajte prodajalno, v kateri ste pohištvo kupili.  
Predali imajo največjo nosilnost 10 kg.

Ne uporabljajte abrazivnih krp, praškov, jeklene volne ali sredstev, ki lahko raztopijo površino pohištva.



## БЪЛГАРСКИ

### Инструкция за монтаж:

1. Запознайте се внимателно с инструкциите за монтаж;
2. Уверете се, че всички части на артикула са налични;
3. Уверете се, че всички крепежни елементи (винтове, гайки и др.) са налице;
4. Осигурете необходимите за сглобяването инструменти;
5. Освободете подходящо и достатъчно място за сглобяването;
6. Продължете към монтажа.

### Съвети за поддръжка:

1. Почиствайте старателно от прах;
2. Използвайте мека и чиста кърпа и подходящ почистващ препарат.



В никакъв случай не пренатягайте!  
След известно време затегнете винтовете отново.  
Запазете инструкцията за монтаж.  
Ако някоя част липсва или е счупена, свържете се с магазина, от който сте закупили мебелите.  
Максималната товарносимост на чекмеджетата е 10 кг.

Не използвайте абразивни препарати:  
прахообразни продукти, стоманена вата,  
разтворители!

## ROMANIA

### SFATURI DE MONTAJ

1. Studiați cu atenție instrucțiunile de asamblare;
2. Verificați dacă toate piesele care compun mobilierul sunt prezente;
3. Grupați și verificați hardware-ul;
4. Echipați-va cu sculele necesare asamblării;
5. Amenajează o zonă de asamblare;
6. Continuați cu asamblarea.



Nu forțați niciodată ansamblurile.  
Strângeți șuruburile după o perioadă de utilizare.  
Păstrați instrucțiunile de asamblare  
Dacă o piesă lipsește sau este ruptă, contactați punctul de vânzare.  
Greutatea maximă suportată de sertare este de 10 kg.

Nu utilizați niciodată praf abraziv, lână de sticlă sau solvenți.

### SFATURI DE ÎNTREȚINERE

1. Curatați praful bine;
2. Umeziți cu apă ușor săpun o cârpă moale și curată.

## SRPSKI

### UPUTSTVO ZA MONTAŽU

1. PAŽLJIVO PROČITAJTE UPUTSTVO ZA MONTAŽU;
2. PREKONTROLIŠITE PREMA UPUTSTVU DA LI IMATE SVE POTREBNE DELOVE;
3. PREKONTROLIŠITE DA LI IMATE SVE ŠRAFOVE, MATICE I OSTALE METALNE DELOVE;
4. OSUGURAJTE POTREBAN ALAT ZA SASTAVLJANJE;
5. PRIPREMITE ODGOVARAJUĆI PROSTOR ZA MONTIRANJE;
6. UKOLIKO STE PROVERILI SVE GORE NAVEDENO MOŽETE ZAPOČETI MONTAŽU.



PRILIKOM MONTIRANJA NE POKUŠAVATI NASILNO SPAJANJE DELOVA.  
NAKON DUŽEG VREMENA KORIŠĆENJA PROIZVODA, ŠRAFOVE PONOVRNO PRIČVRSTITI.  
UKOLIKO VAM NEDOSTAJE ODREĐENI DEO, MOLIMO VAS DA KONTAKTIRATE PRODAJNI CENTAR GDE STE NAMEŠTAJ KUPILI. FIOKA IMA MASKIMALNU NOSIVOST 10 KG.

NE KORISTITI ABRAZIVNE KPPE, PUDERE, ČELIČNU VUNU ILI SREDSTVA KOJA MOGU OŠTETITI POVRŠINU NAMEŠTAJA.

### SAVETI ZA ODRŽAVANJE

1. UKLANJAJTE REDOVNO PRAŠINU I NEČISTOĆU;
2. ODRŽAVANJE MEKOM I VLAŽNOM KRPOM UZ UPOTREBU BLAGOG DETERDŽENTA.

(IT) ISTRUZIONI DI MONTAGGIO  
(GB) ASSEMBLING INSTRUCTIONS  
(FR) NOTICE DE MONTAGE  
(SLO) NAVODILA ZA MONTAŽO  
(SRB) UPUTSTVO ZA MONTAŽU

(D) MONTAGEANLEITUNG  
(ES) INSTRUCCIONES DE MONTAJE  
(P) INSTRUCOES DE MONTAGEM  
(HR) UPUTE ZA MONTAZU  
(RO) FOAIE CU INSTRUCIUNI  
(BG) ИНСТРУКЦИИ ЗА СГЛОБЯВАНЕ

**IMPORTANTE:** Per evitare il ribaltamento accidentale del mobile è obbligatorio il fissaggio a muro. I tasselli necessari per il collegamento mobile/muro, dipendenti dal tipo di muro, non sono compresi. Consultare uno specialista in caso di dubbi.

**IMPORTANT:** To avoid the accidental tip-over of the furniture, the fixing of the furniture on the wall is mandatory. The needed hardware for the junction wall/furniture, depending of the nature of the wall, is not provided. If any doubt, consult a specialist.

**IMPORTANT:** Pour éviter le basculement accidentel du meuble, la fixation du meuble au mur est obligatoire. La visserie nécessaire pour la jonction mur/meuble, dépendante de la nature du mur n'est pas fournie. En cas de doute, consulter un spécialiste.

**WICHTIG:** Um die versehentliche Trübung der Möbel zu vermeiden, ist die Befestigung der Möbel an der Wand obligatorisch. Die benötigte Hardware für die Verbindungswand / Möbel, je nach Art der Wand, ist nicht vorgesehen. Wenn irgendwelche Zweifel, konsultieren Sie einen Spezialisten.

**IMPORTANTE:** Para evitar el vuelco accidental de los muebles, la fijación de los muebles en la pared es obligatoria. El hardware necesario para la pared / los muebles de la unión, dependiendo de la naturaleza de la pared, no se proporciona. En caso de duda, consulte a un especialista.

**IMPORTANTE:** Para evitar a queda accidental do mobiliário, a fixação dos móveis na parede é obrigatória. O hardware necessário para a junção parede / móveis, dependendo da natureza da parede, não é fornecido. Em caso de dúvida, consulte um especialista.

**VAŽNO:** Da bi se izbjeglo slučajno tip-over namještaja, fiksiranje namještaja na zidu je obavezno. Potreban hardver fot na spoj zida / namještaja, ovisno o prirodi zida, nije predviđeno. Ako imate bilo kakve sumnje, konzultirati stručnjaka.

**VAŽNO:** U CILJU IZBEGAVANJA SLUČAJNOG PREVRTANJA NAMEŠTAJA OBAVEZNO JE FIKSIRANJA ISTOG UZ ZID. NIJE PREDVIĐEN HARDVER FOT NA SPOJU ZIDA I NAMEŠTAJA. U SLUČAJU NEJASNOĆA POTREBNO JE KONSULTOVATI STRUČNO LICE.

## OPOZORILO:

Da ne bi pohištva prevrnili, je pritrditev pohištva na steno obvezna.

Deli, potrebni za pritrditev pohištva na steno, ki so odvisni od vrste stene, niso priloženi.

Če ste v dvomih, se posvetujte s strokovnjakom.

## Важно:

За да избегнете случайно преобръщане на мебелите, те трябва да бъдат фиксирани към стената.

Не са включени дюбелите, необходими за прикрепването на мебелите към стената в зависимост от нейния вид.

При въпроси и съмнения се консултирайте със специалист!

**IMPORTANT:** Pentru a evita rasturnarea accidentala a mobilierului, fixarea pe perete este obligatorie. Mufele necesare pentru racordarea dulap/perete, in functie de tipul de perete, nu sunt incluse. Consultați un specialist dacă aveți dubii.

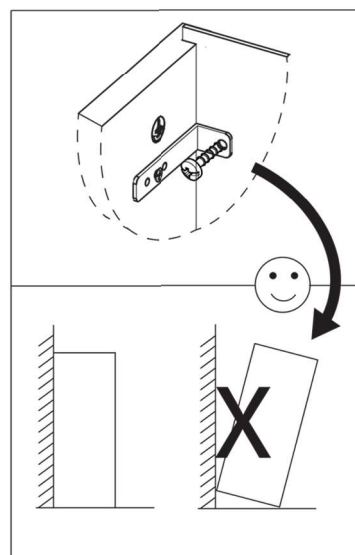

	Cod.	Parcel number	Size - mm.	Description	n.
1	8WEBEFF003D	8WEBEFF003D		FRIDGE	1
2	8WXXKEX9021	8WXXKEX9021		HOOD	1
3	8WEBEPC006N	8WEBEPC006N		HOB	1
4	8WXXLXO791D	8WXXLXO791 D		SINK	1
5	8WEBEFO010N	8WEBEFO010N		OVEN	1
6	8WEBEMI001X	8WEBEMI001X		MICROWAVE	1
7	8WEBELV001	8WEBELV001		DISHWASHER	1

	Cod.	Parcel number	Size - mm.	Fridge unit l.60 h.216	n.
8-1	4WXXWP7SP604	2WLNWP6050	596X716X18	DOOR	1
8-2	4WKTGC1BA004	2WASGC6039	563X531X18	BOTTOM	1
8-3	4WXXWP7SP804	2WLNWP6050	596X1316X18	DOOR	1
8-4	5MRGC2029	2WLNRY6054	225X578X3	BACK PANEL	1
8-5	4WKTGC3CA004	2WASGC6039	563X531X18	TOP	2
8-6	PWXXRY3FD505	2WLNRY6054	2040X560X18	RH SIDE	1
8-7	PWXXRY3FS505	2WLNRY6054	2040X560X18	LH SIDE	1

	Cod.	Parcel number	Size - mm.		n.
9	2WLNRYPP609WPS	2WLNRYPP609WPS		WALL UNIT L.60 H.96	1
10	2WLNRYPP609WPD	2WLNRYPP609WPD		WALL UNIT L.60 H.96	1

	Cod.	Parcel number	Size - mm.		n.
11	4WMMCMTBL2164	2WMMCMTBL2164	2102X600X38	TOP	1

	Cod.	Parcel number	Size - mm.	Sink cabinet	n.
12-1	4WKTGC1BA004	2WMMRY6102GC	563X531X18	BOTTOM	1
12-2	4WXXRY1FI201	2WMMRY6102GC	720X560X18	LH-RH SIDE	2
12-3	4WXXWP7SP604	2WLNWP7129	596X716X18	DOORS	1
12-4	9WXXGC1FA132	2WMMRY6102GC	563X67X18	JOIN CHAIN	3
13	9WXXAPLA601	9WXXAPLA601		UNDER SINK PROTECTOR	1

	Cod.	Parcel number	Size - mm.		n.
14	2WLNRYCF356WPS	2WLNRYCF356WPS		OVEN UNIT	1
15	2WLNRYBCC927WP	2WLNRYBCC927WP		3 DRAWERS CHEST	1
16	8WXXZAK501	8WXXZAK501		PLINT	1
17	9WXXALZOC51	9WXXALZOC51		PLINT	1
18	9WXXAPFA601	9WXXAPFA601		UNDER FRIDGE PROTECTOR	1
19	4WXXWP7SP61	2WLNWPJSL406	596X716X18	DISHWASHER DOOR	1
20	8WXXZAK501	8WXXZAK501		BACKSPLASH	1

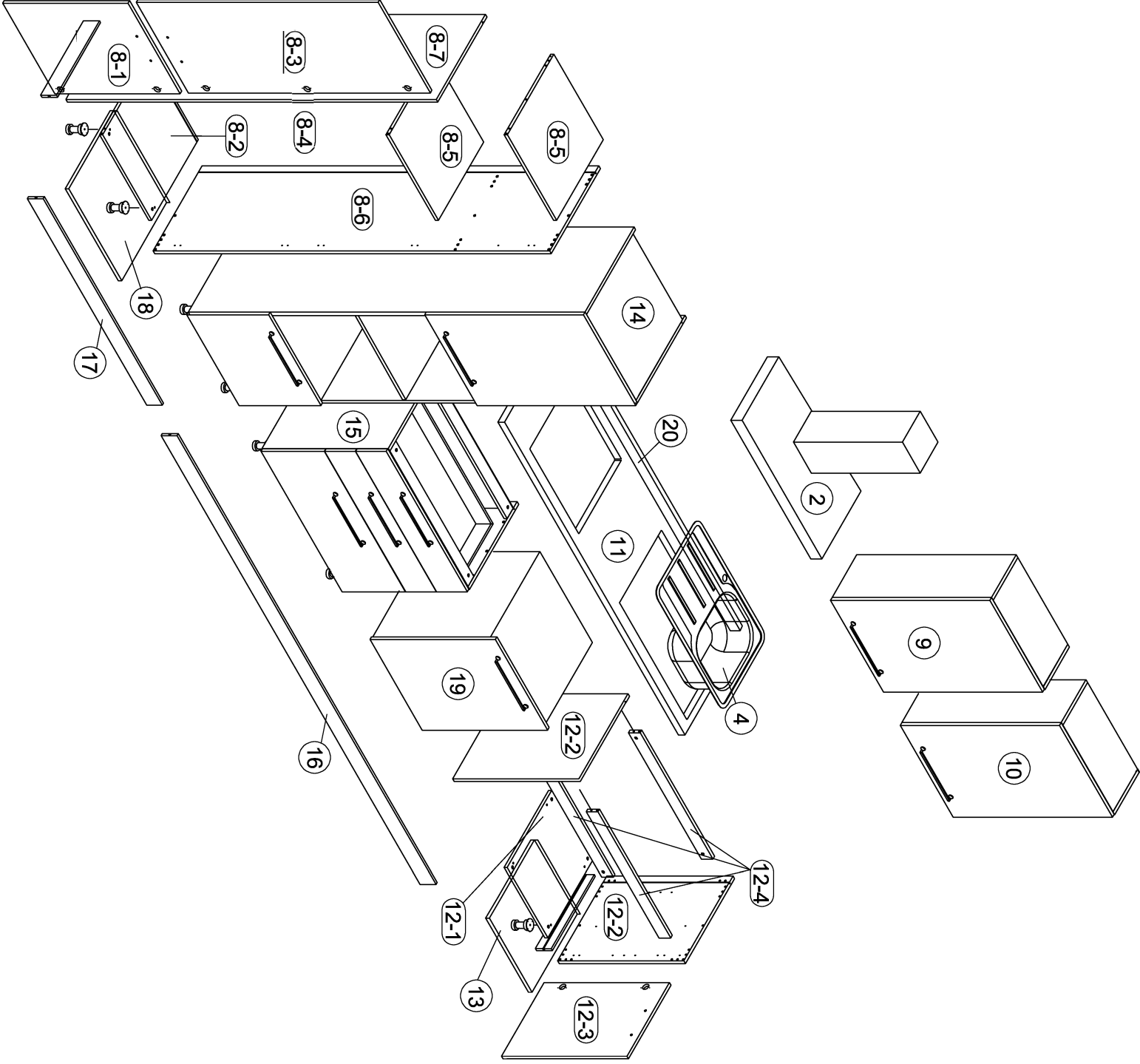

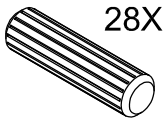

28X

5SIFA2000



22X

FFMON2065

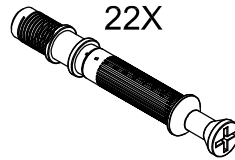

22X

FFMON2083

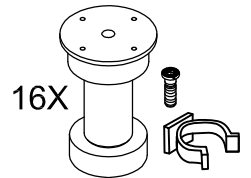

16X

8WXXAPBN01



1X

FFCOL2000

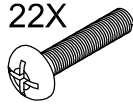

22X

FFVAN2018  
4MAX22



18X

FFVAN2056  
3.5X15

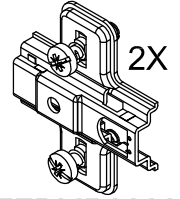

2X

FFBMP2020

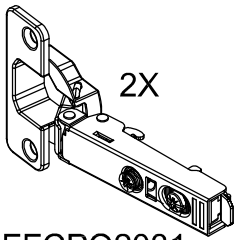

2X

FFCPO2031

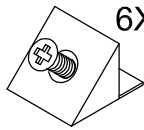

6X

FFFSZ2007

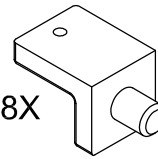

8X

FFFPC2004

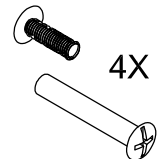

4X

FFGPN2226

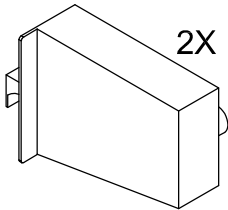

2X

Z-ATTA01

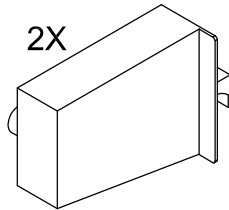

2X

Z-ATTA02

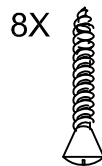

8X

FFVAN2050  
4x25

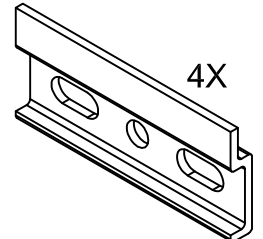

4X

FFBAR5007

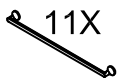

11X

FFMAN2334

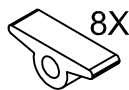

8X

FFRPN2014

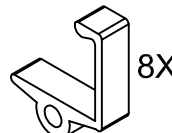

8X

FFRPN2015



16X

FFRPN2016



20X

FFPAR1050

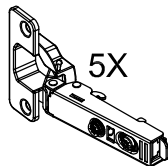

5X

FFCPO5010

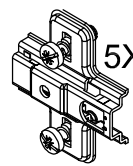

5X

FFBMP5007

8 INR



FFMON2065

12 INR

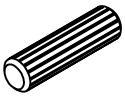

5SIFA2000

X2

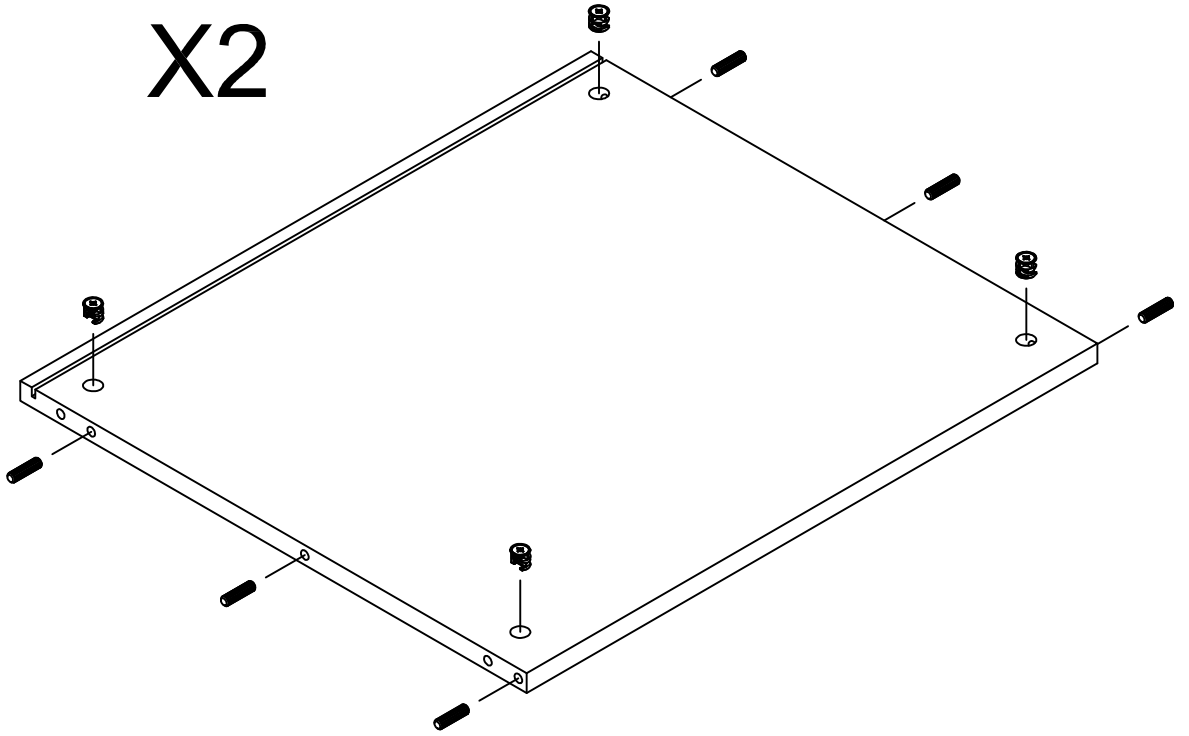

4 INR



FFMON2065

6 INR

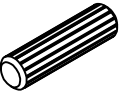

5SIFA2000

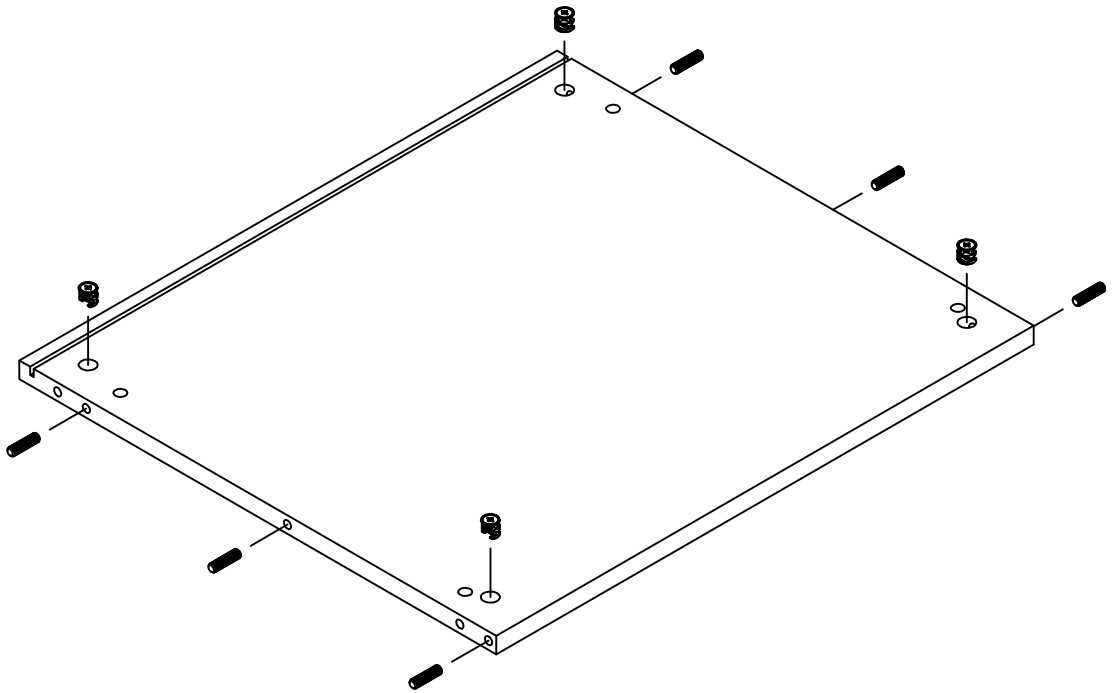

12 <sup>NR</sup>



FFMON2083

5 <sup>NR</sup>



FFBMP2007

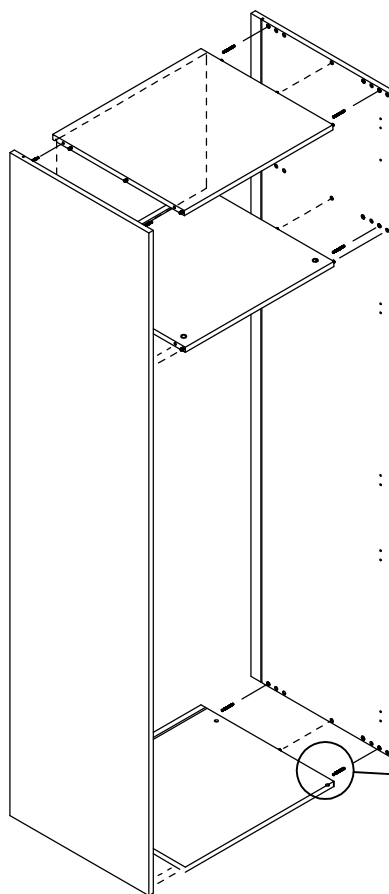
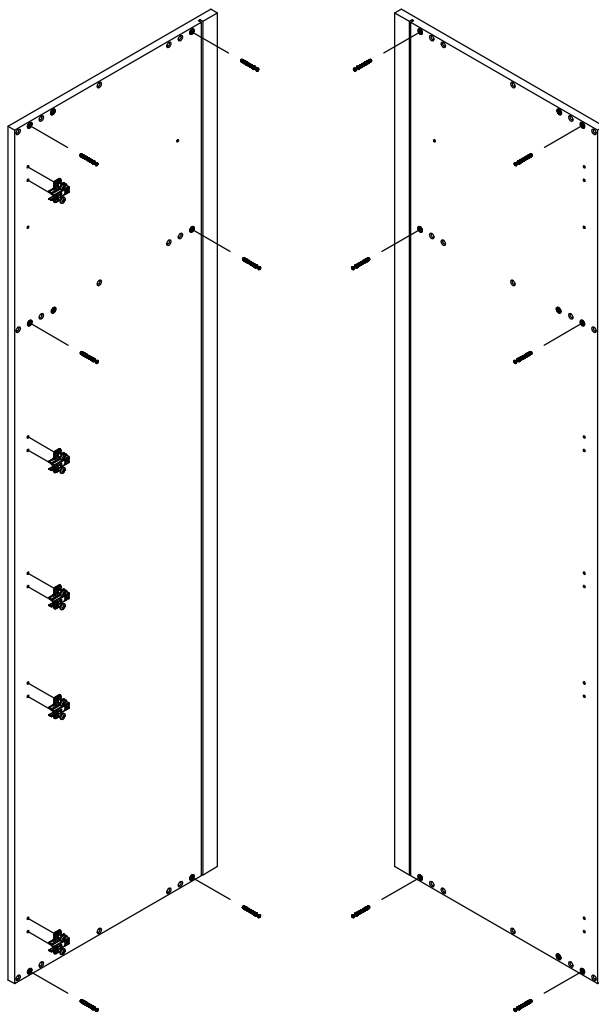

6 INR



FFFSZ2007

2 INR



8SPFE4146

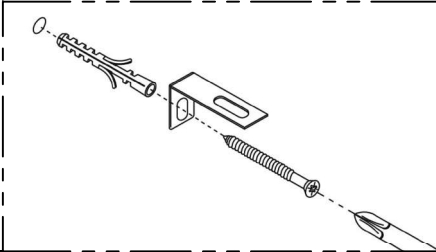
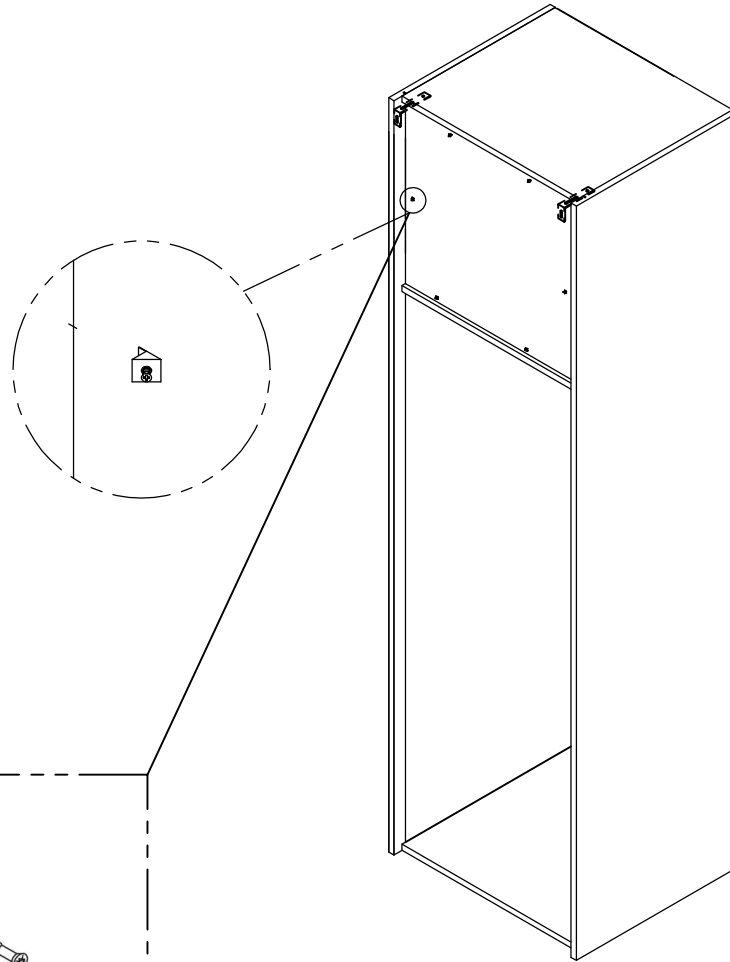

5 INR

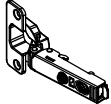

FFBMP2007

10 INR



FFVAN2056  
3,5x15

2 INR



FFMAN2334

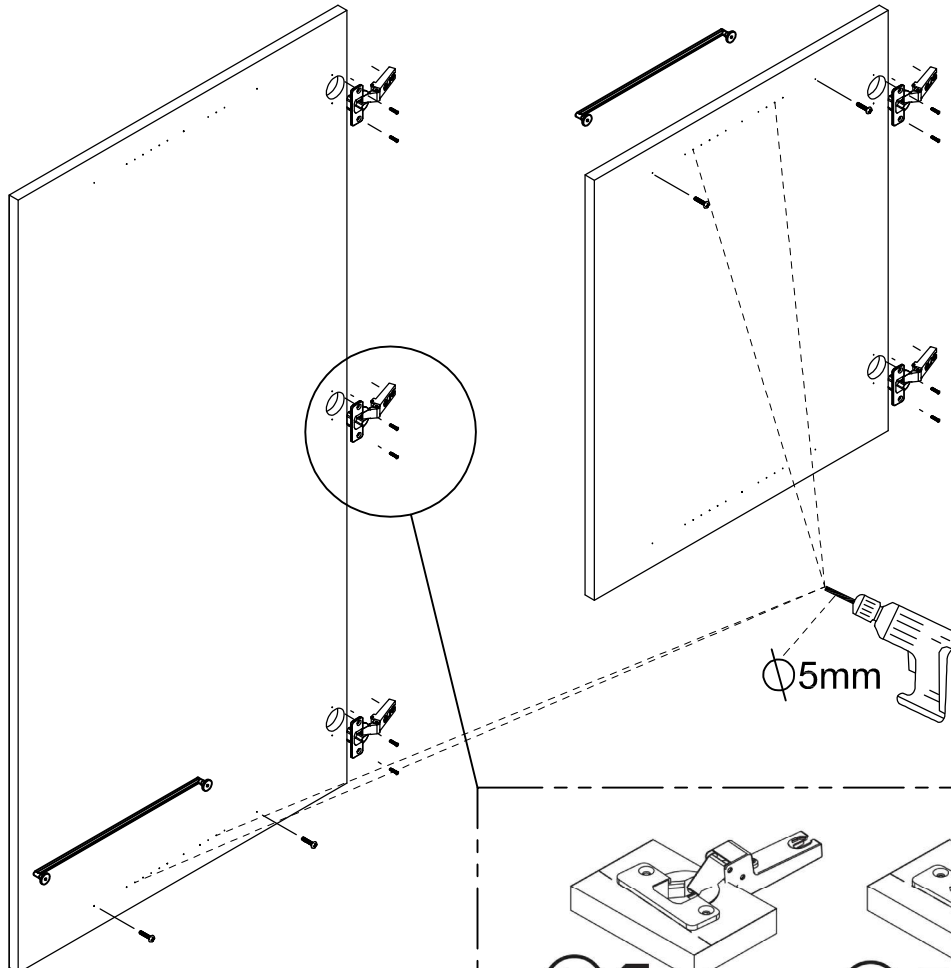

Ø5mm

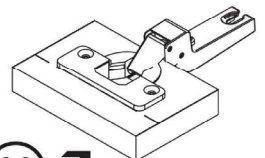
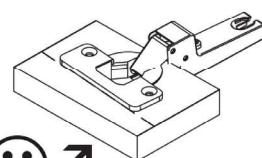

4 INR



FFPAR1050

1 INR

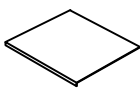

9VXXAPFA601

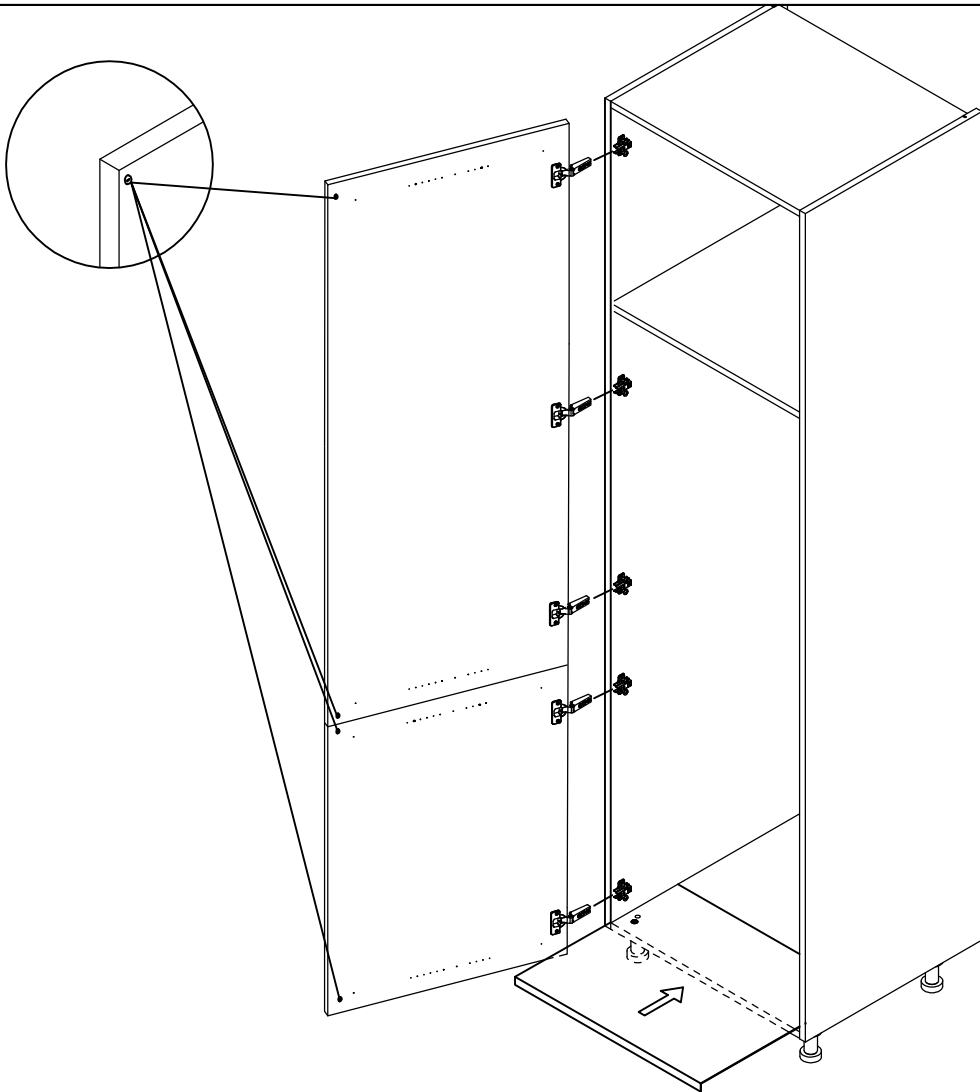
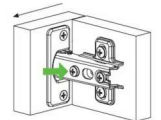
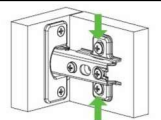
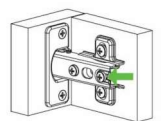
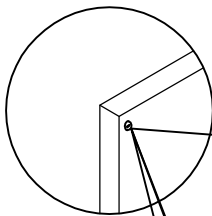

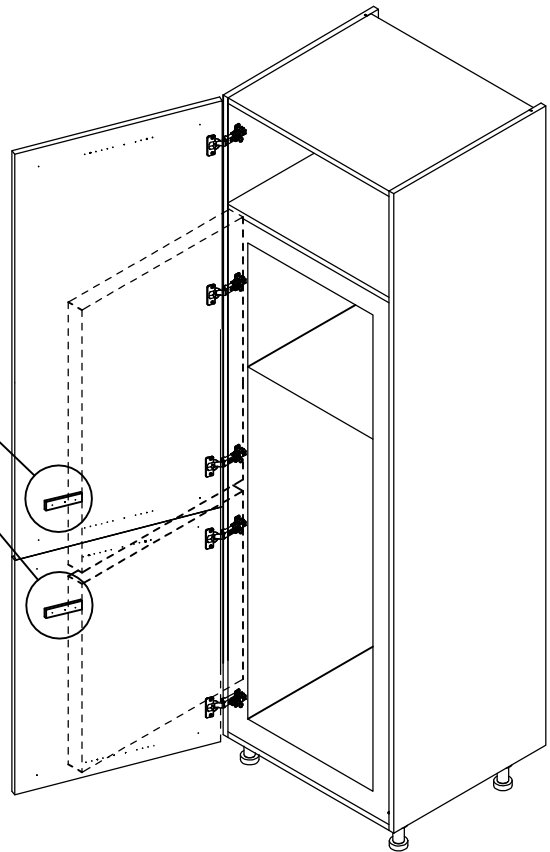
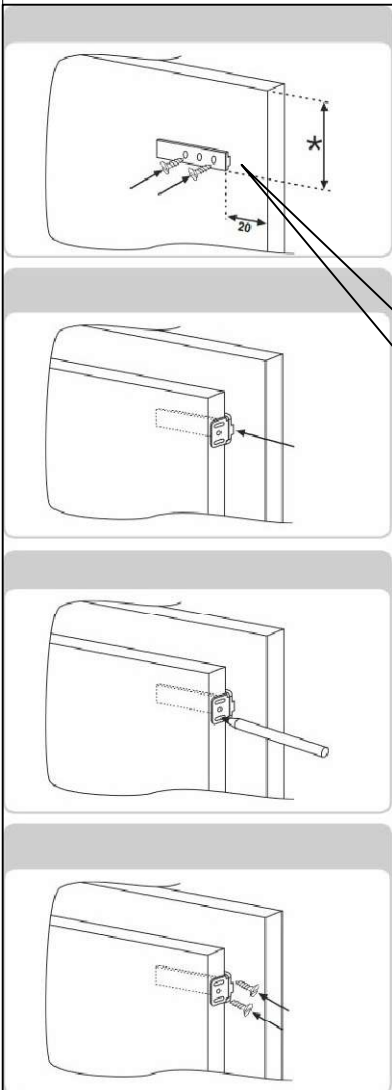
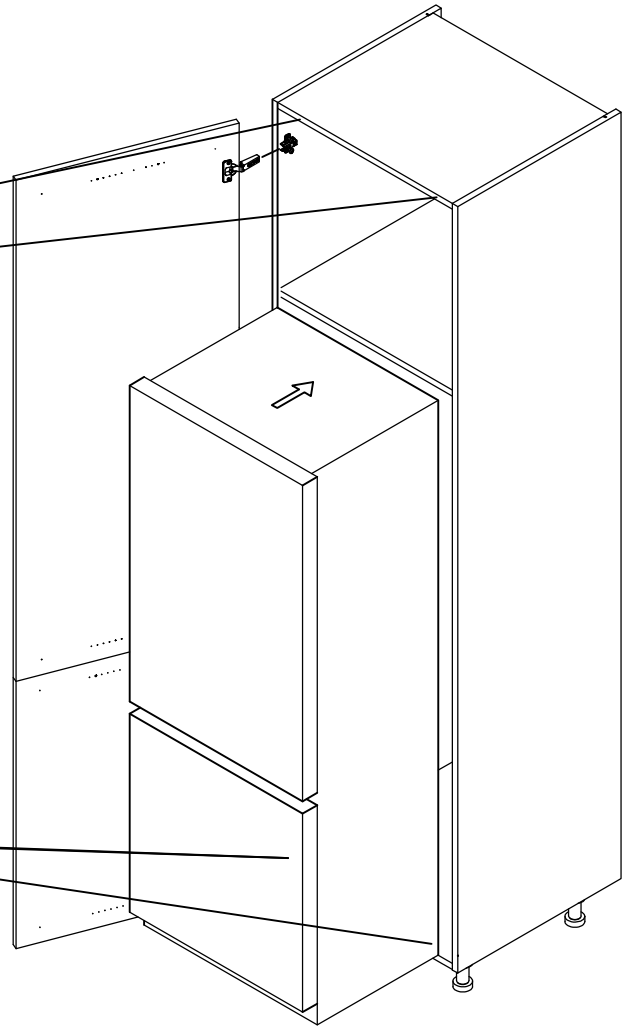
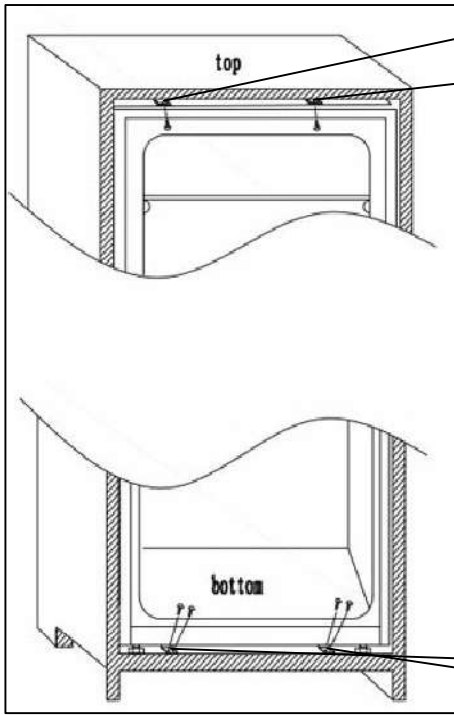

12 INR



5SIFA2000

10 INR



FFMON2065

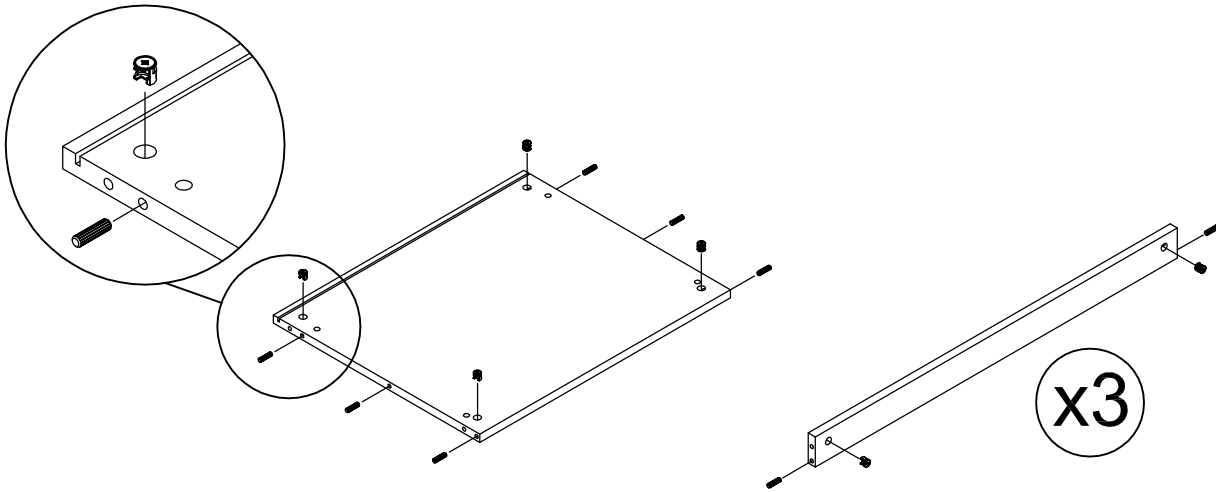

8 INR



FFMON2051

2 INR

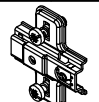

FFBMP2020

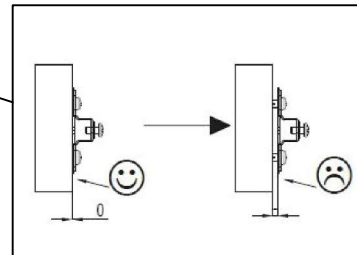
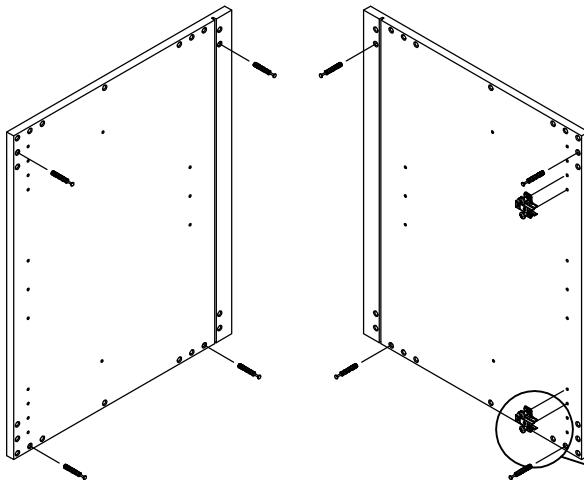

4 INR



8WXXAPBN01

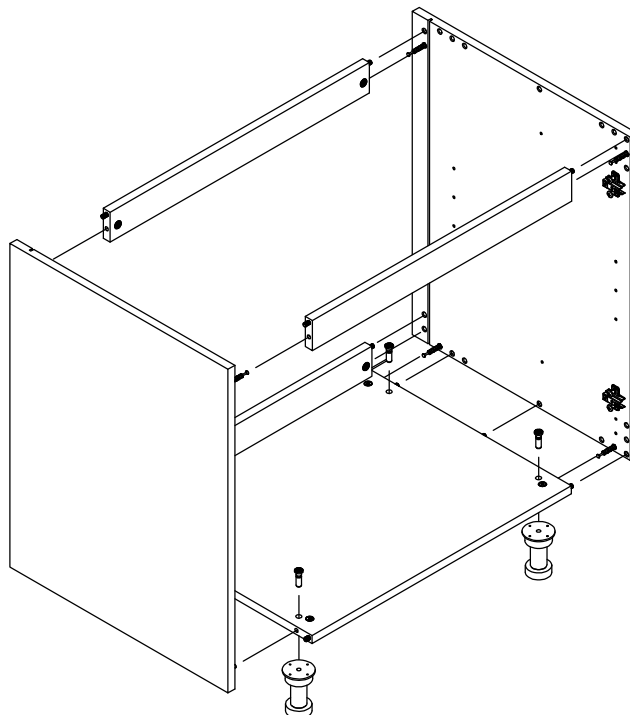
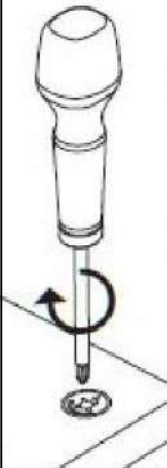

4 INR

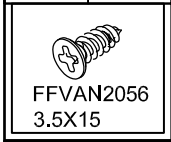

2 INR



2 INR

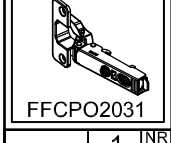

1 INR

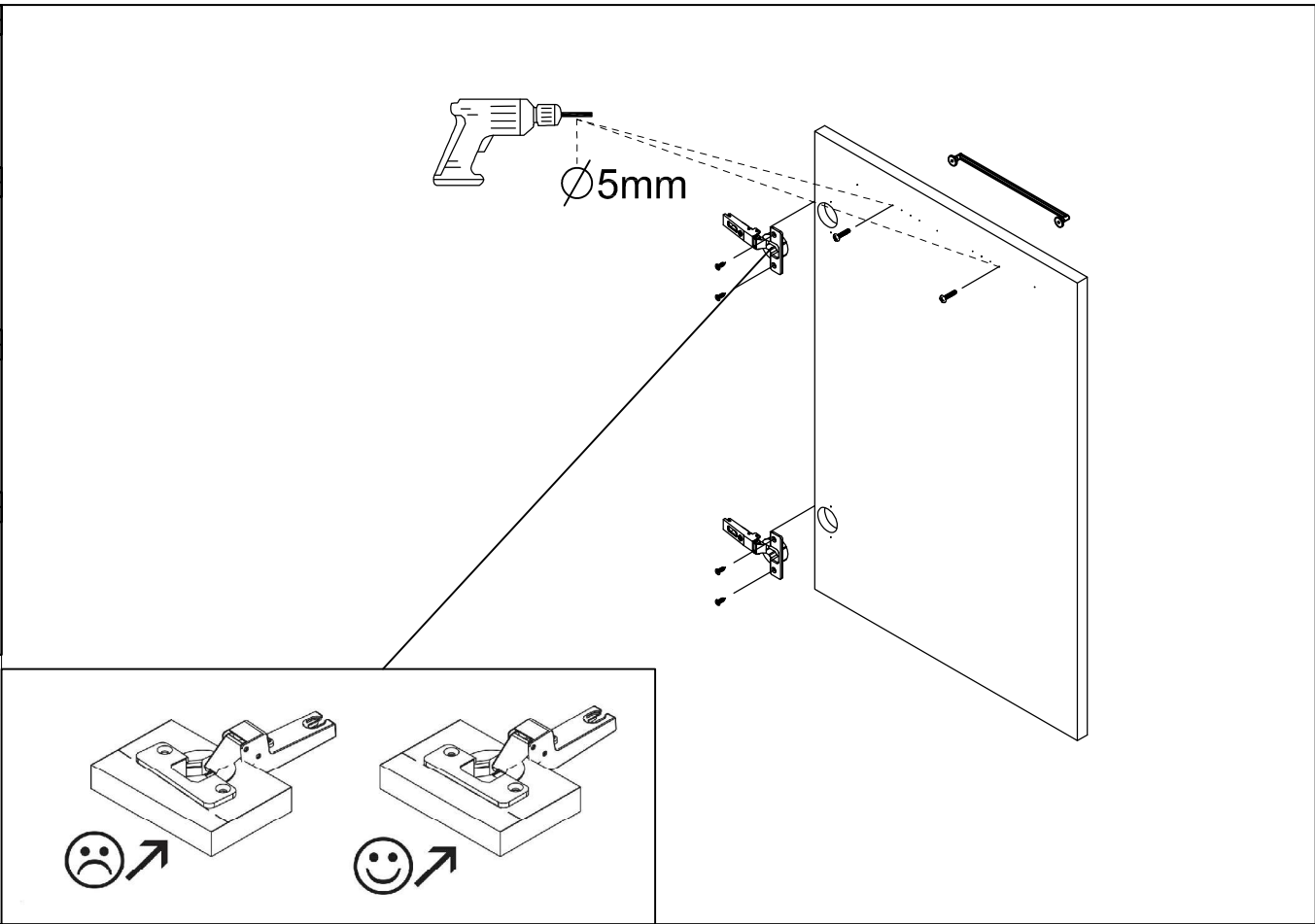
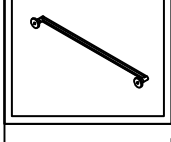

2 INR

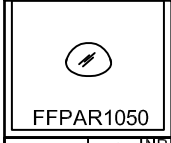

1 INR

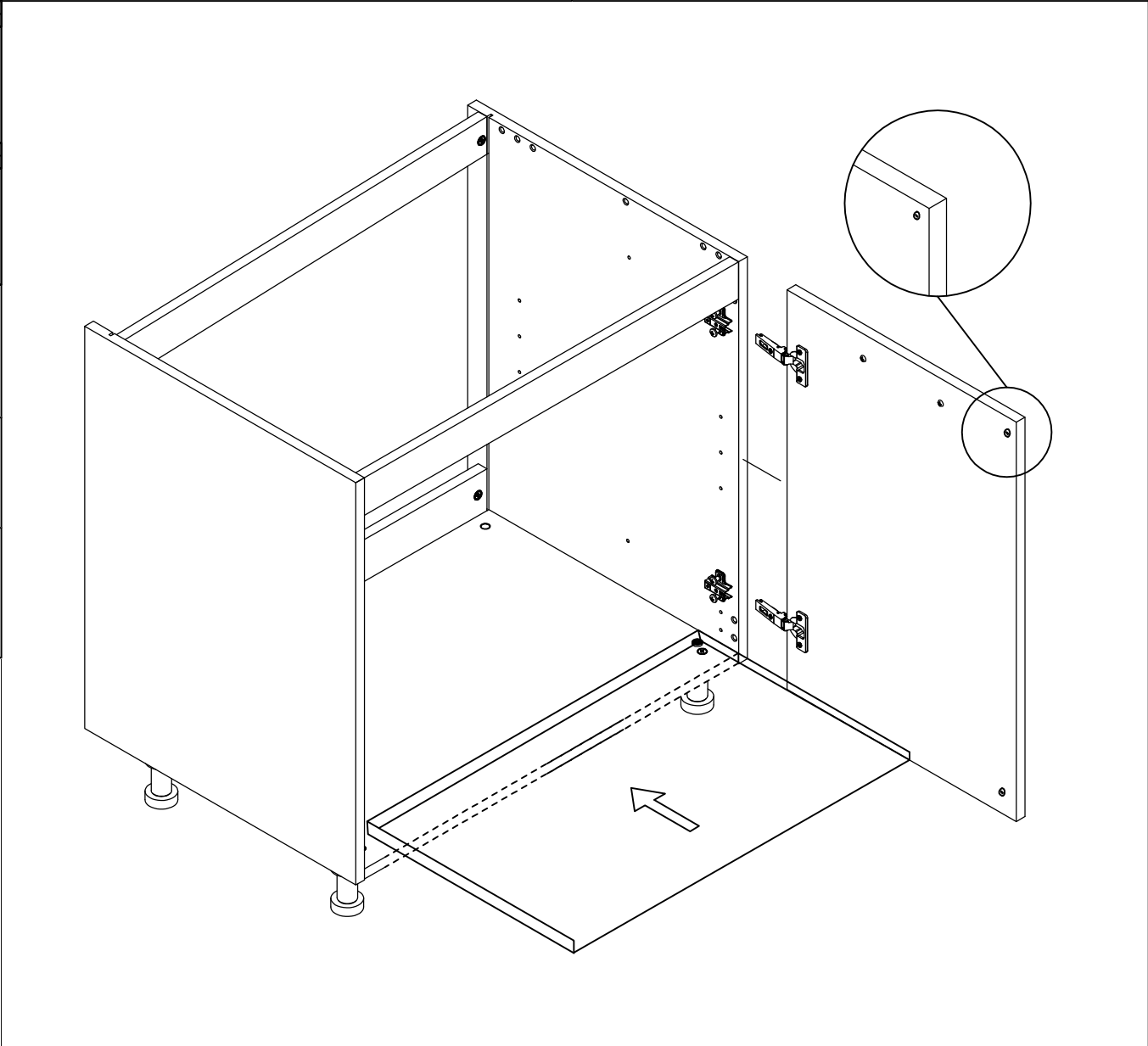
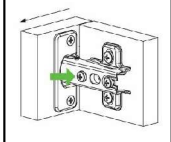
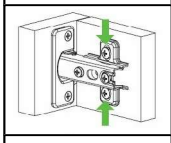
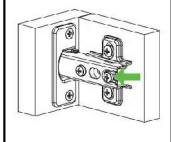
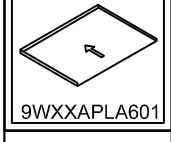

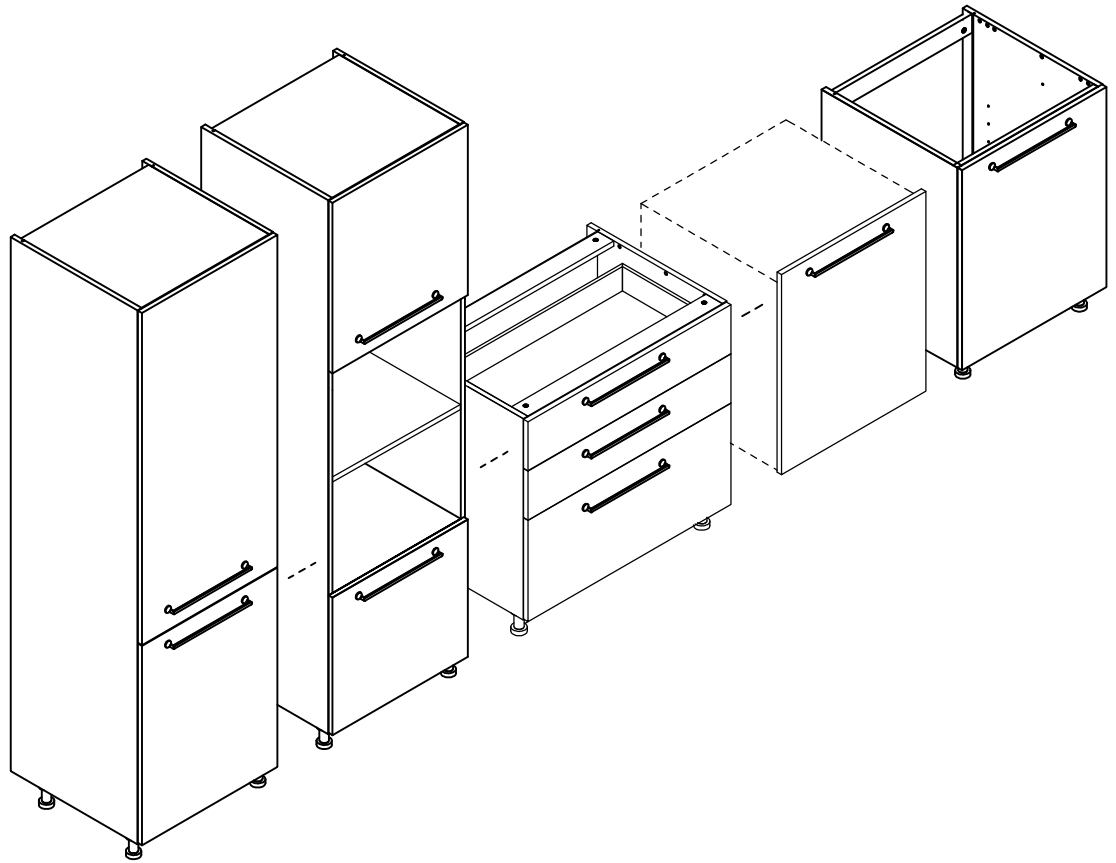

X | 4 | INR



X | 8 | INR

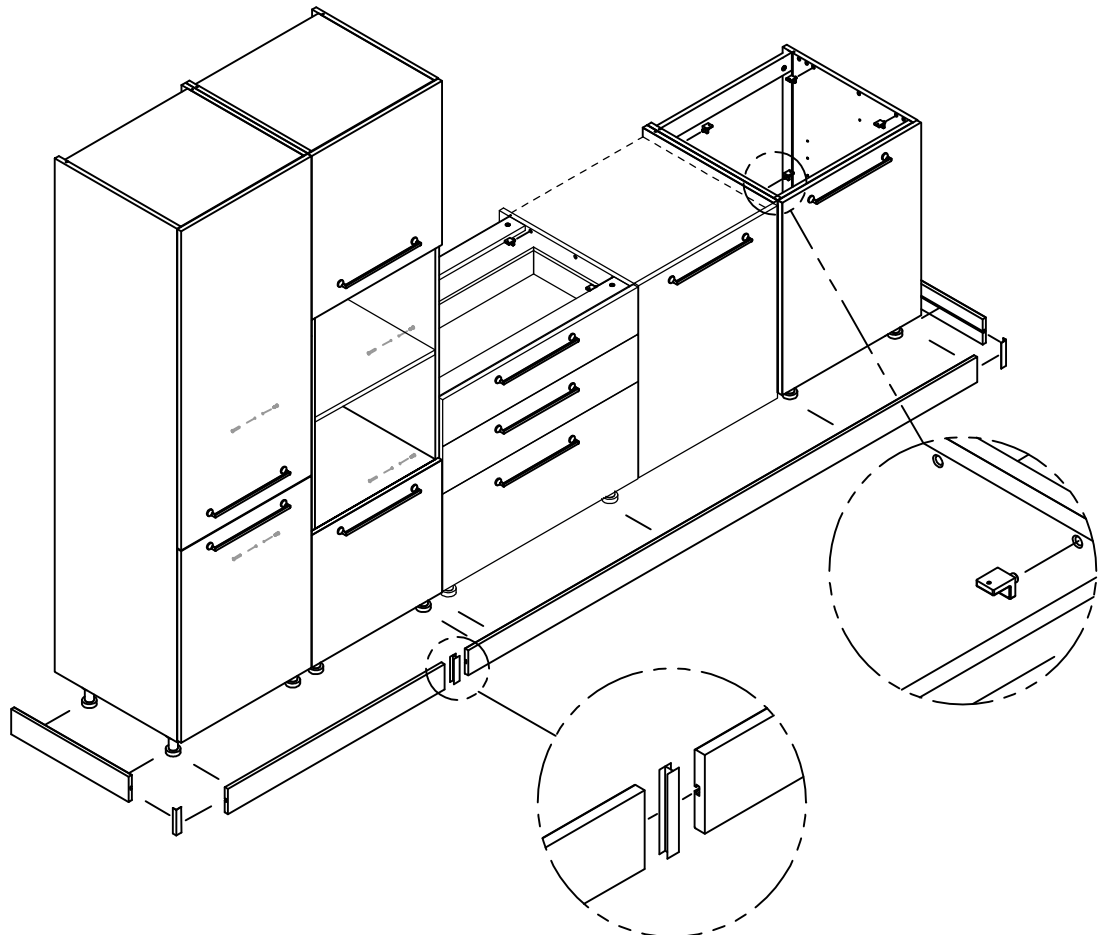
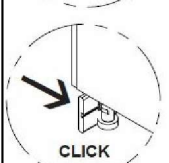
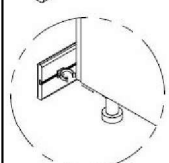
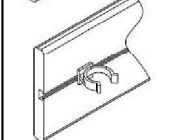
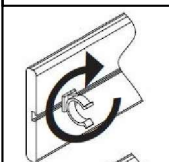
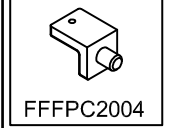

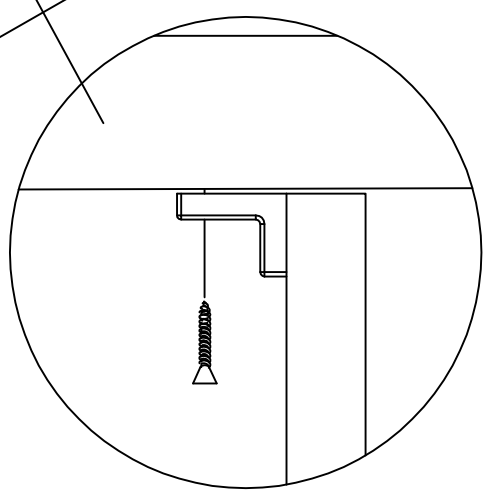
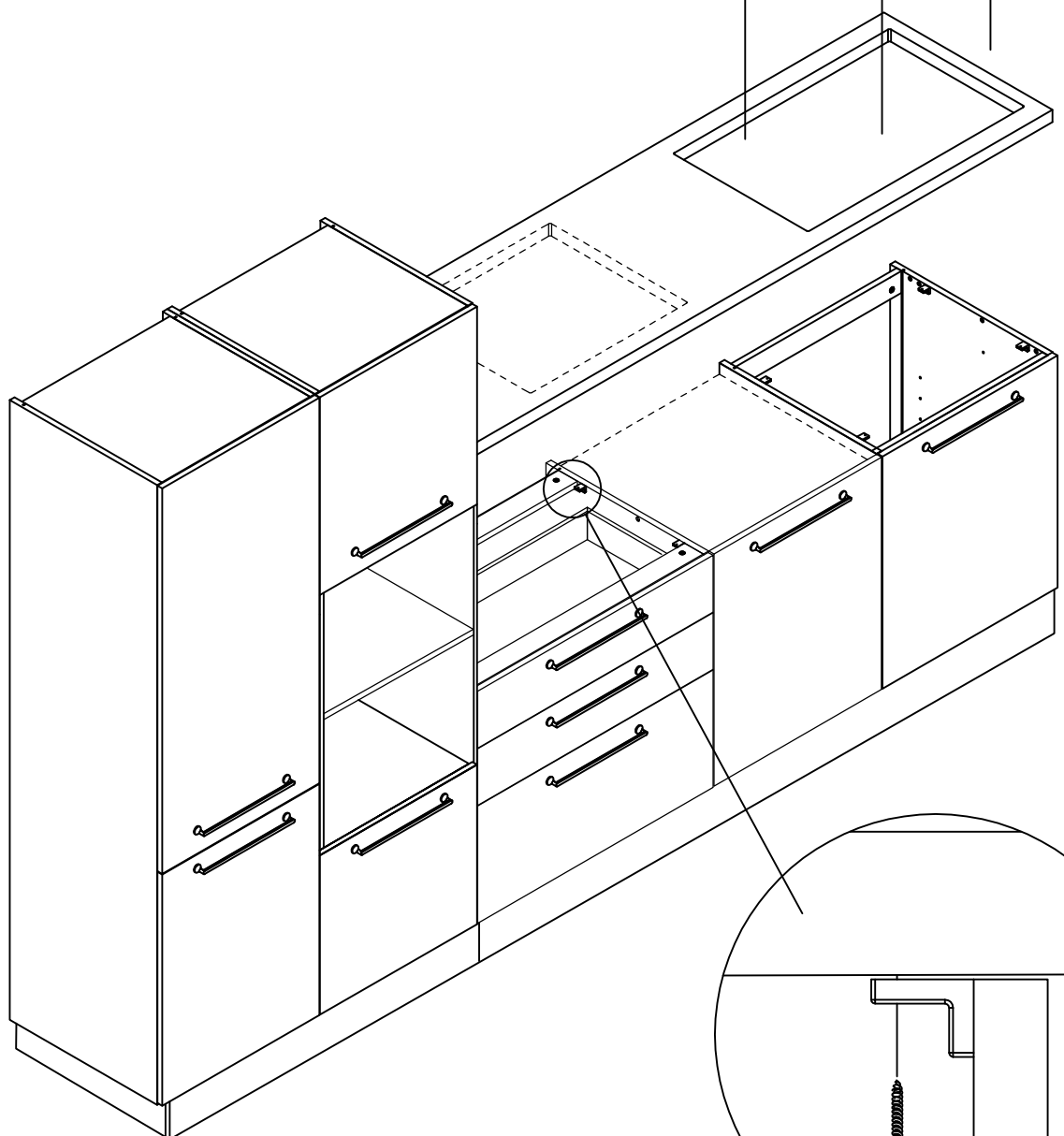
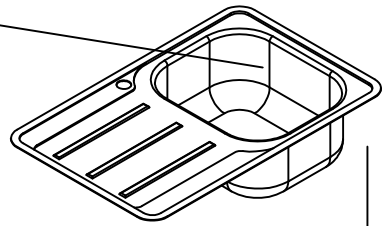
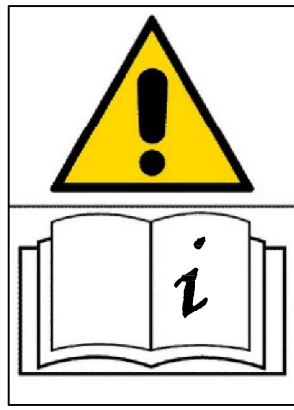

- X 2 INR  
FFGPN2226
- X 4 INR  
FFBAR5007
- X 2 INR  
Z-ATTA02
- X 2 INR  
Z-ATTA01
- X 2 INR
- X 4 INR  
FFVAN2018  
4MAX22

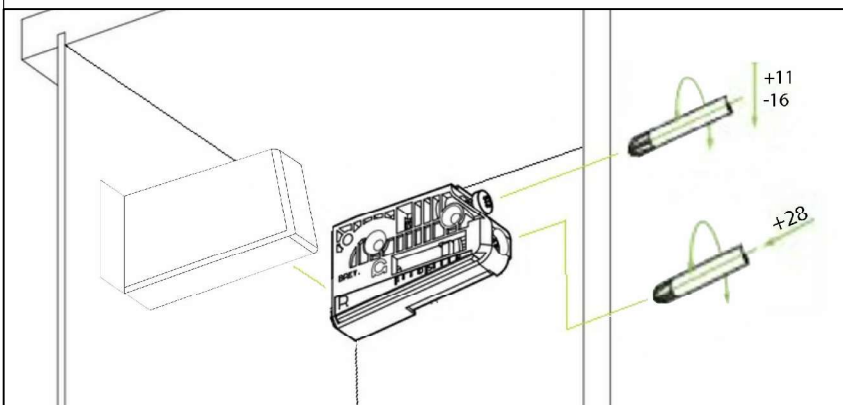
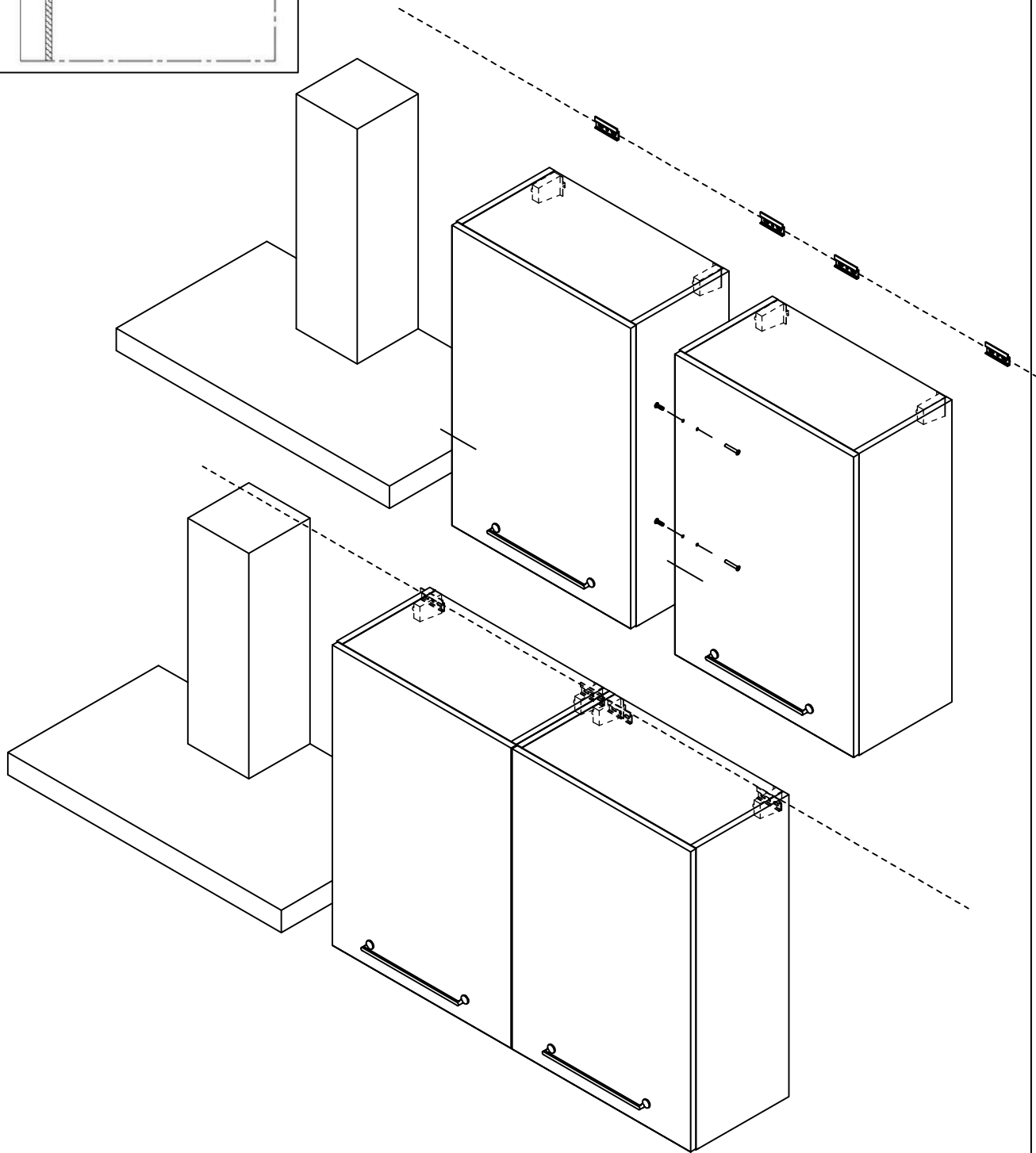
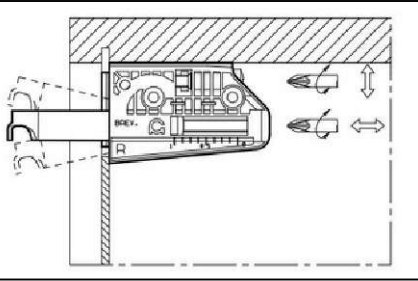

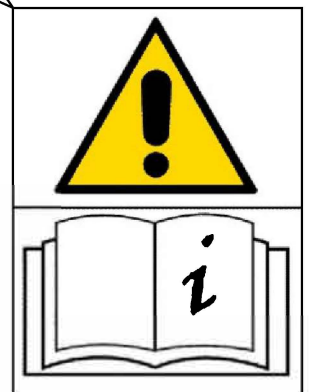
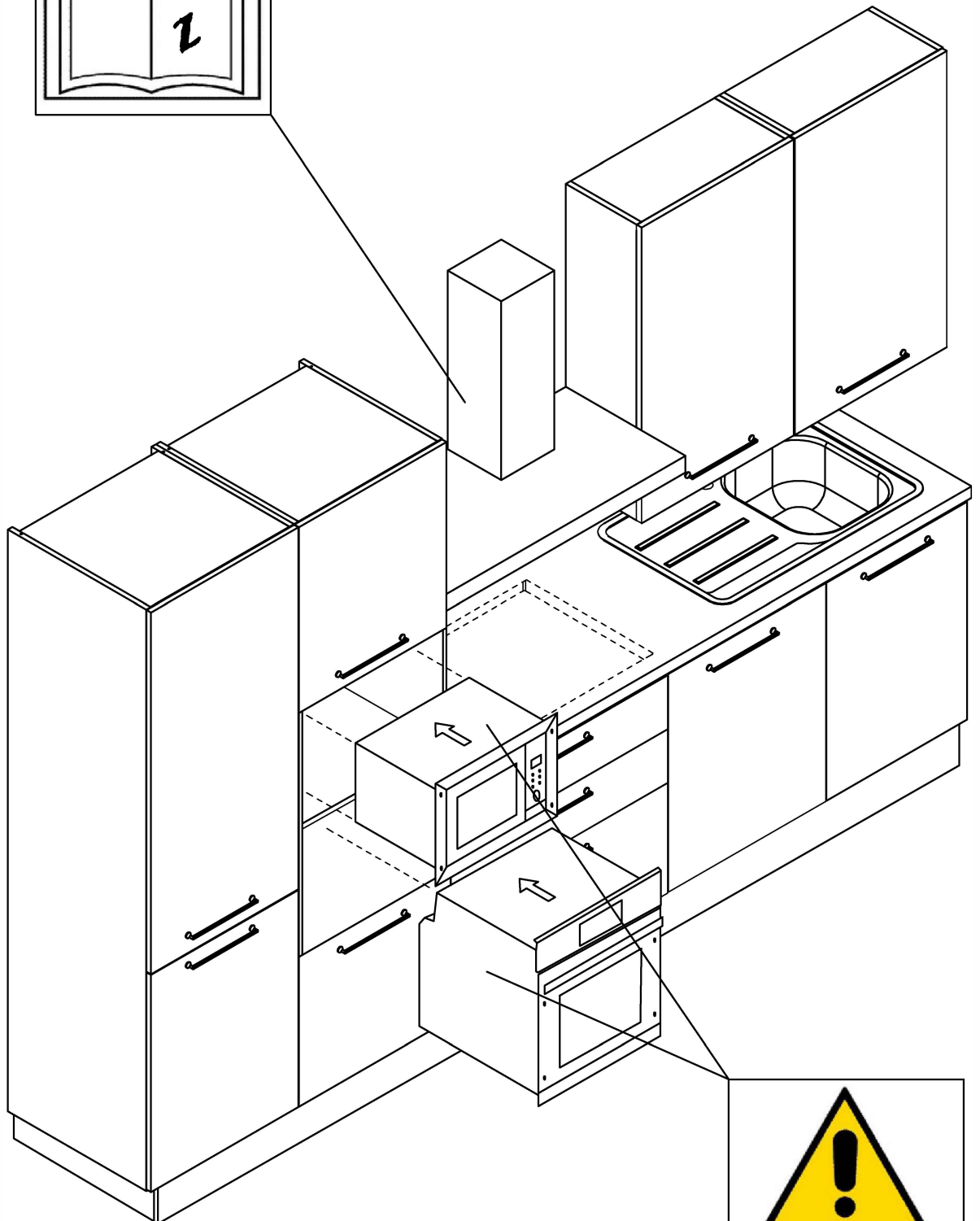
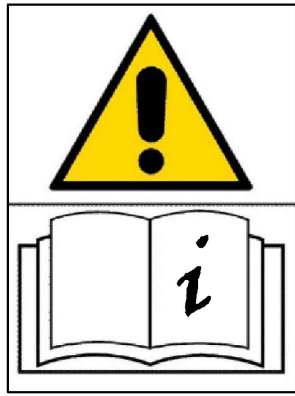

#### Candy (Haier Europe)

- Croatia (Centar za pomoć / Servis): [https://www.candy-home.com/hr\\_HR/gdje-kupiti/](https://www.candy-home.com/hr_HR/gdje-kupiti/)
- Slovenia (Center za pomoč): [https://www.candy-home.com/sl\\_SI/kje-smo/](https://www.candy-home.com/sl_SI/kje-smo/)
- Romania (Centru de asistență): [https://www.candy-home.com/ro\\_RO/cere-asistenta/](https://www.candy-home.com/ro_RO/cere-asistenta/)
- Europa (Home): <https://www.haier-europe.com>

#### Beko

- Romania (Centru de asistență): <https://www.beko.com/ro-ro/support/contact>
- Croatia (Korisnička podrška): <https://www.beko.com/hr-hr/support/help-center>
- Serbia (Korisnička podrška / Servisni centar): <https://www.beko.com/rs-sr/Podrška/obratite-nam-se>