

XXXXXXXXXX serie: xxx

 Hergestellt für:

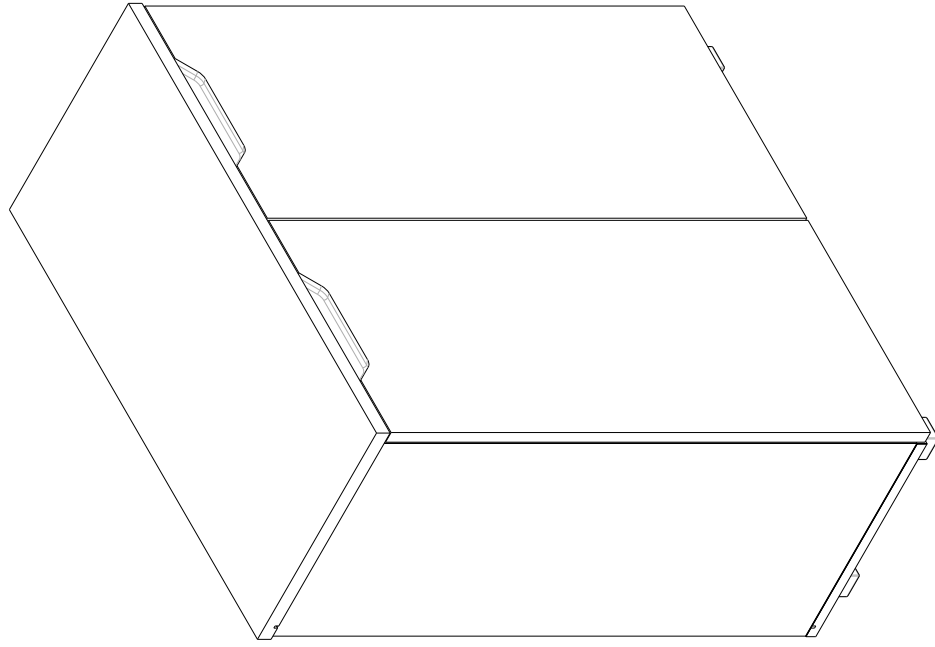

120 min

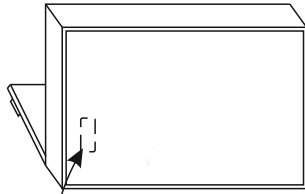
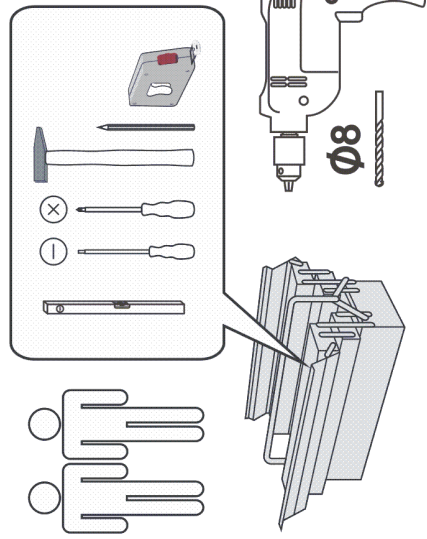
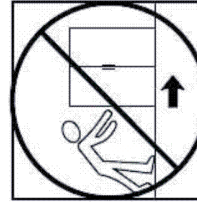
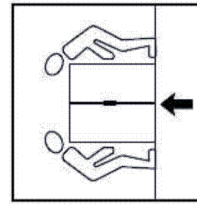
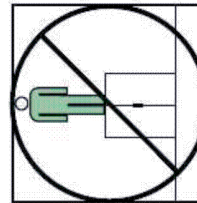
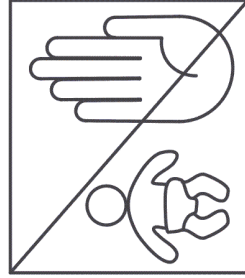
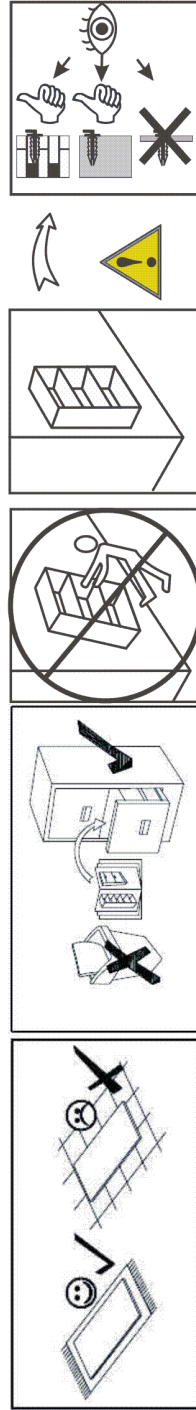

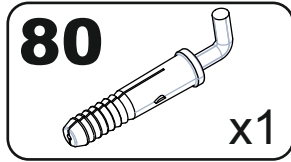
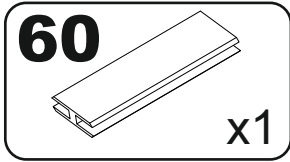
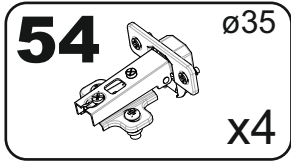
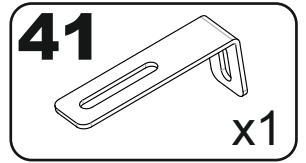
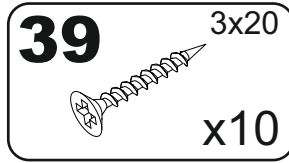
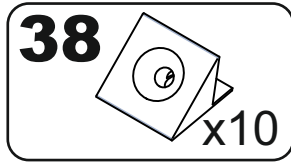
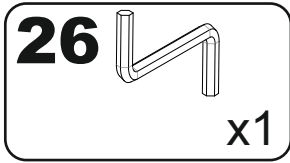
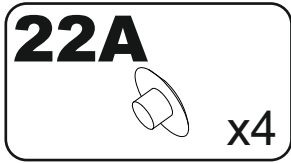
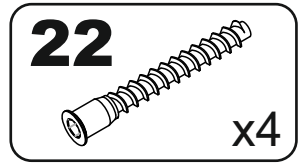
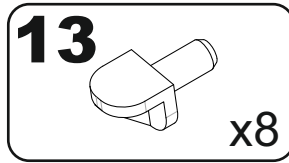
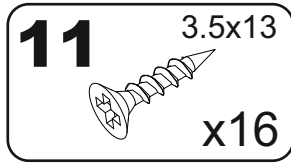
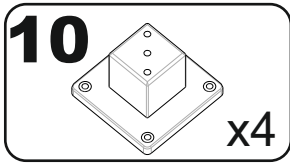
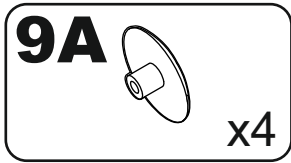
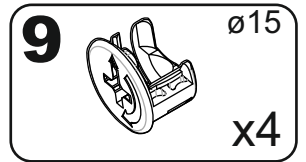
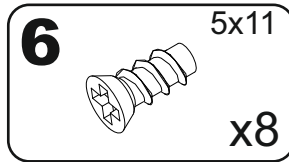
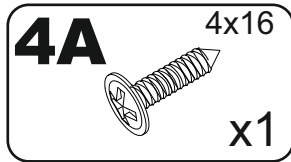
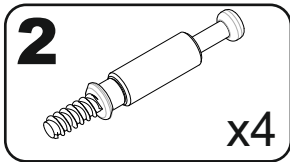
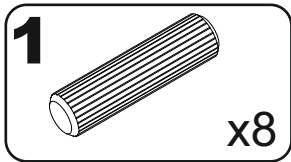
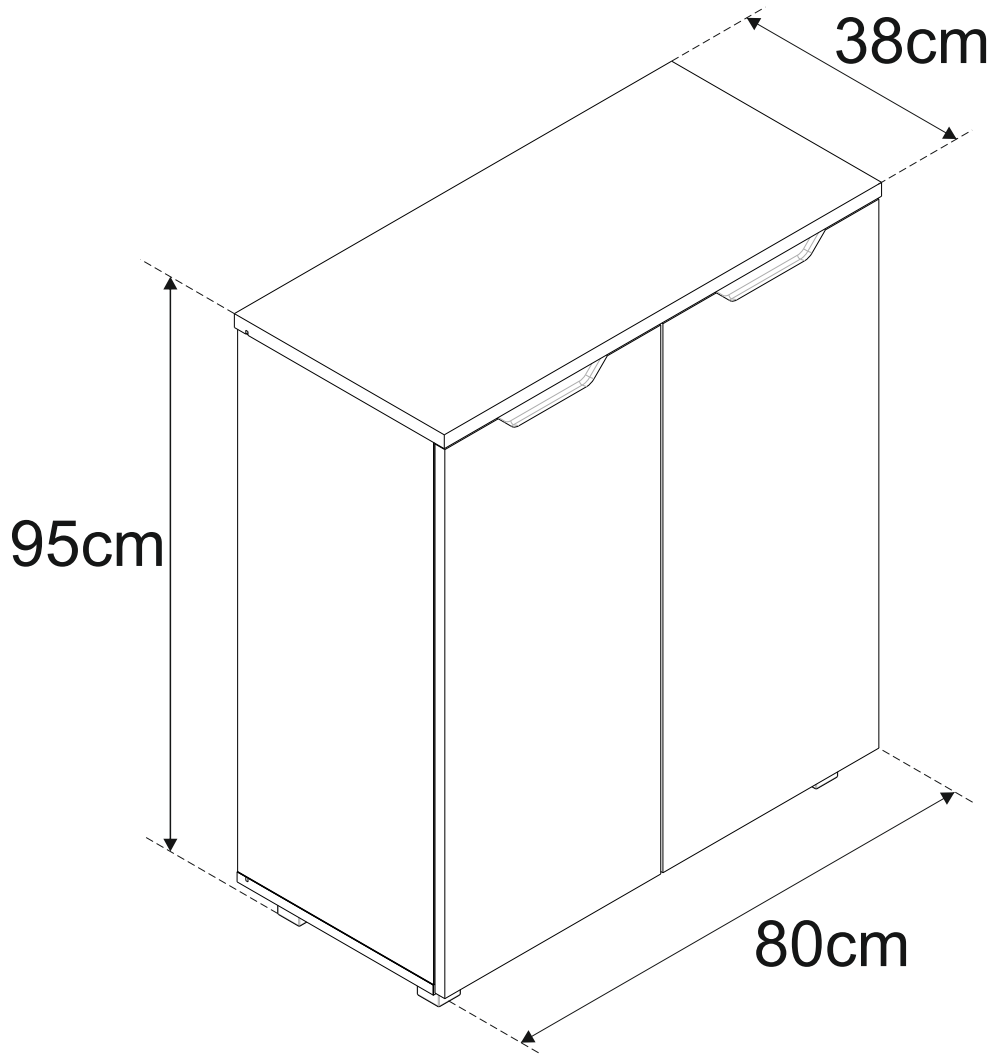
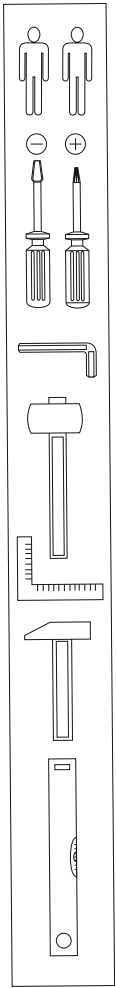

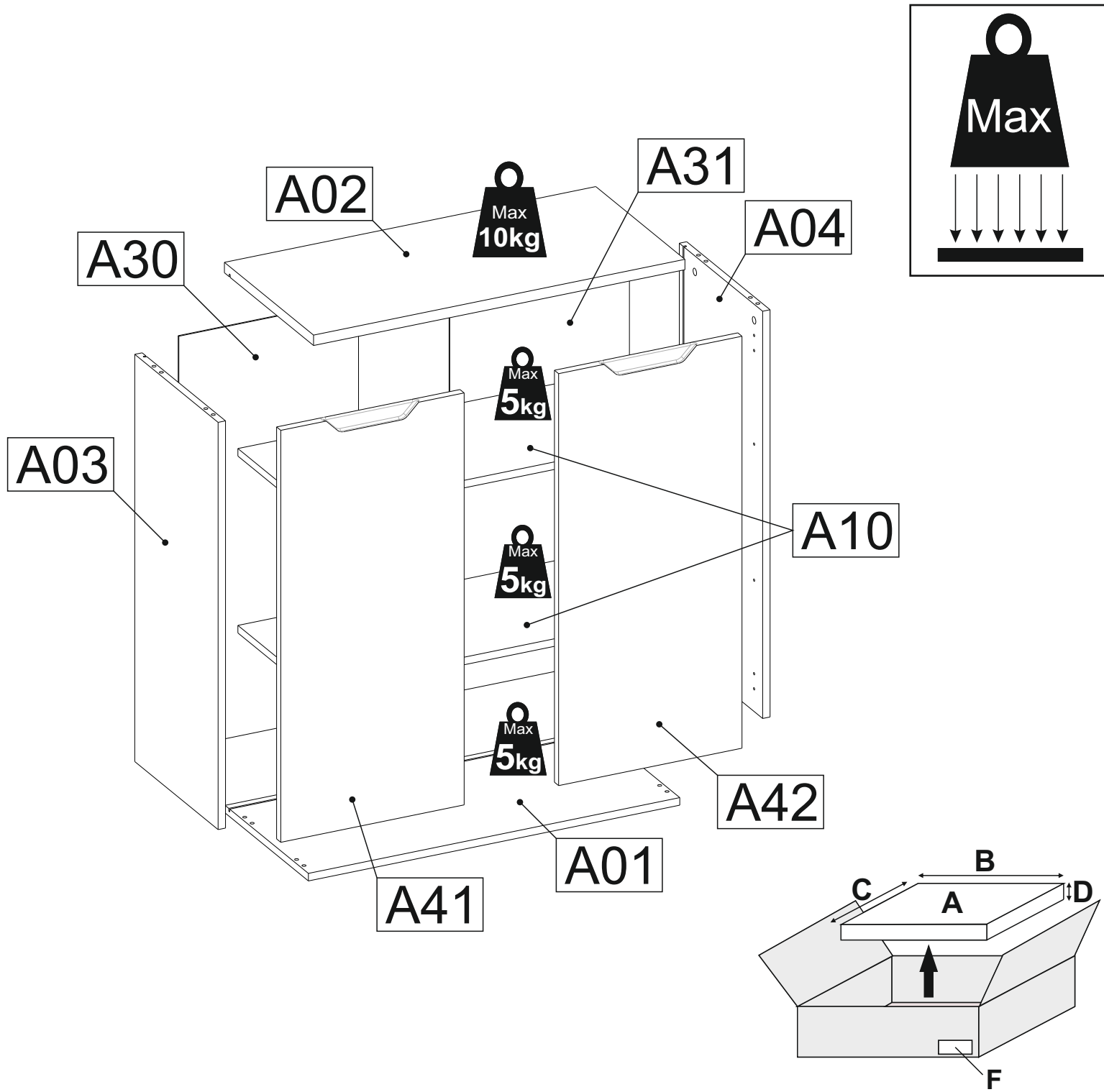

A	B (mm)	C (mm)	D (mm)	E	F
A01	802	360	16	1	1 1
A02	802	385	22	1	1 1
A03	862	360	16	1	1 1
A04	862	360	16	1	1 1
A10	768	330	16	2	1 1
A30	872	388	3	1	1 1
A31	872	388	3	1	1 1
A41	872	396	18	1	1 1
A42	872	396	18	1	1 1

1

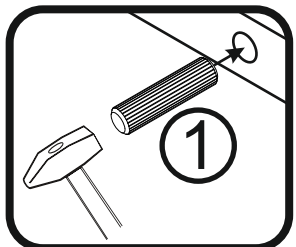
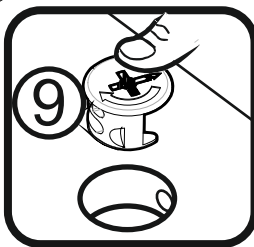
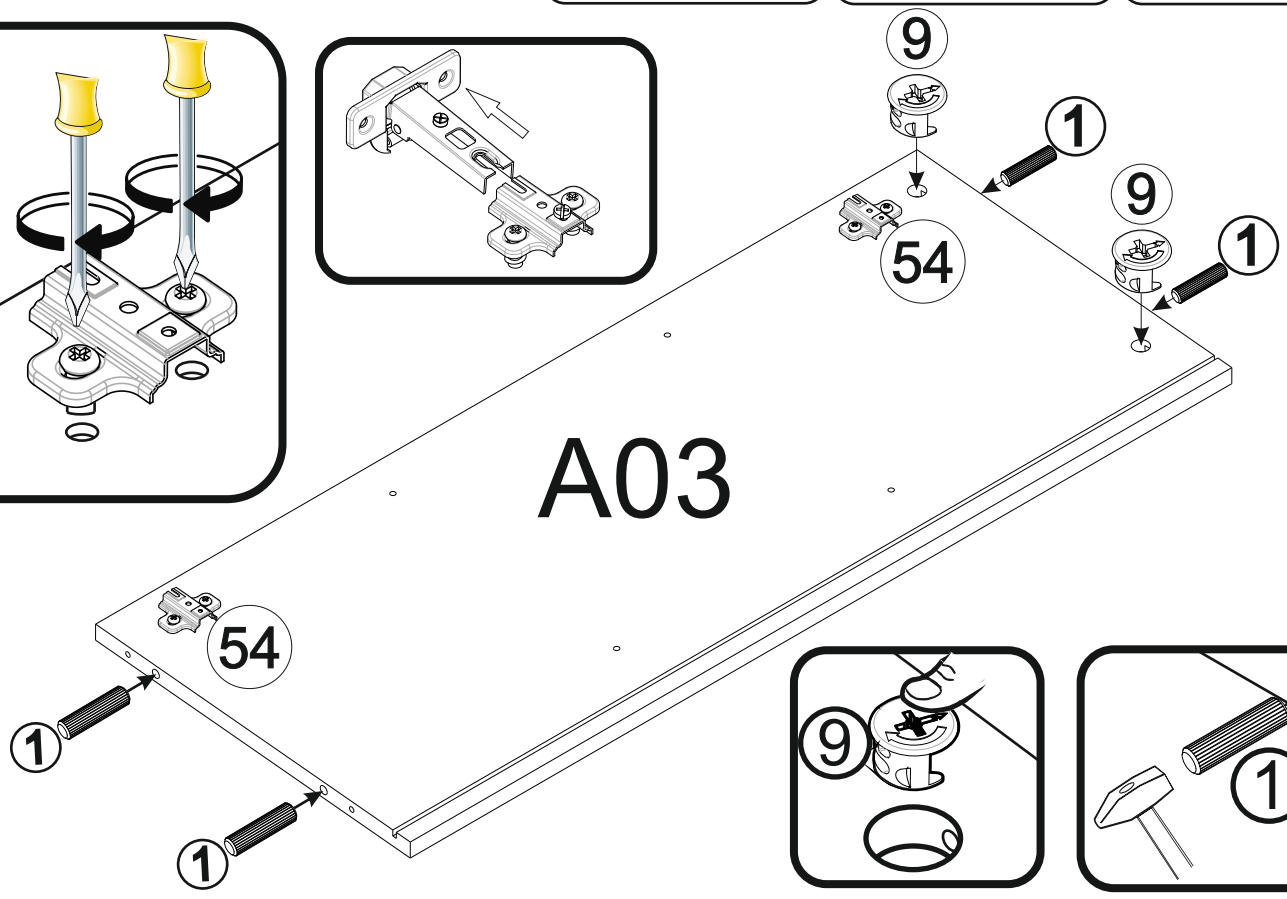
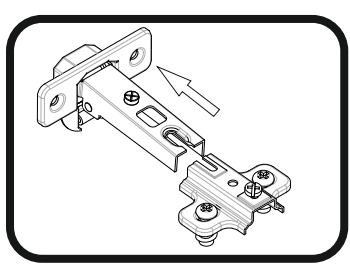
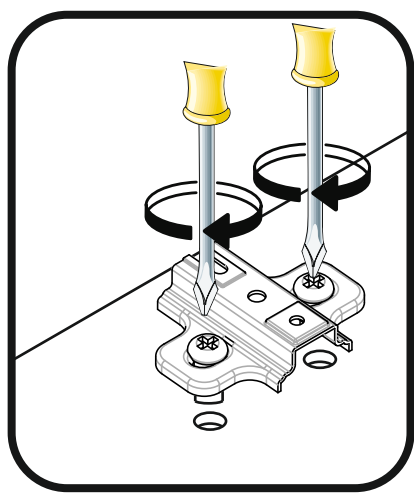
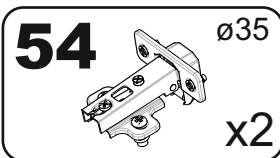
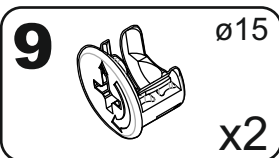
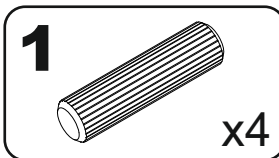

2

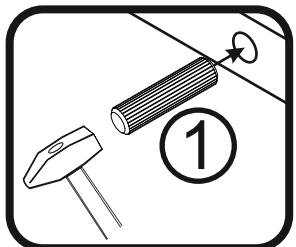
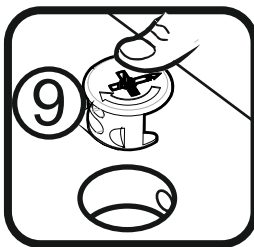
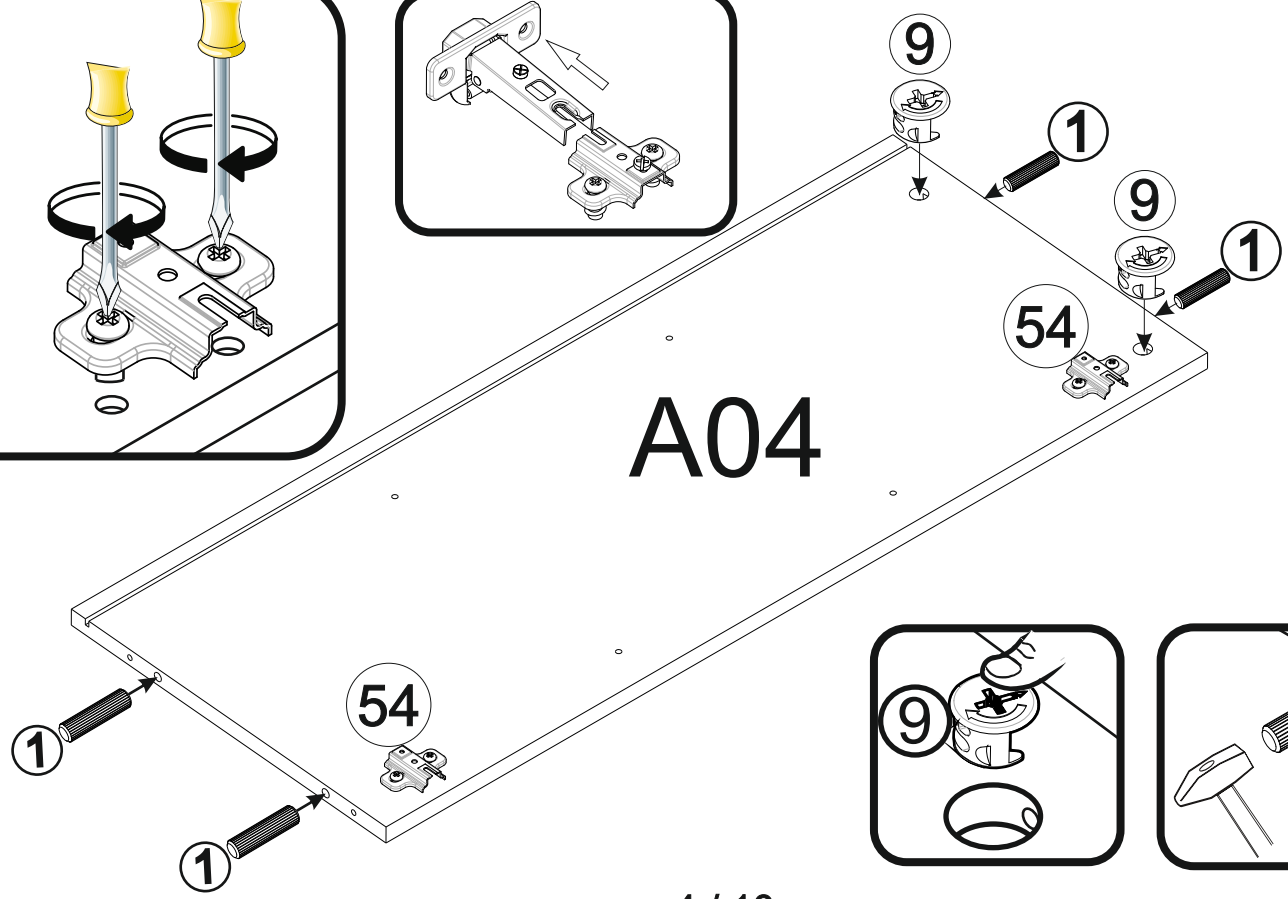
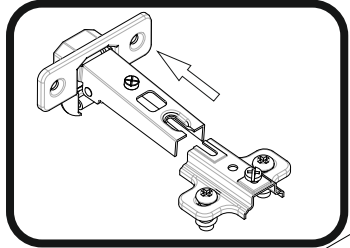
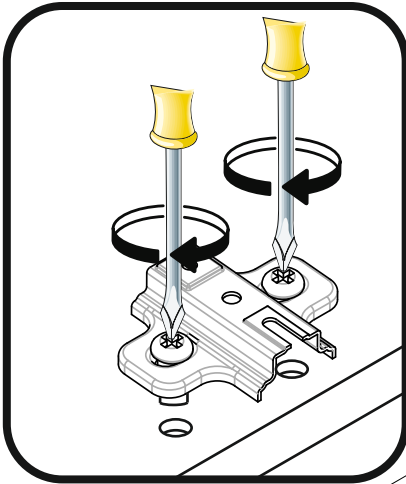
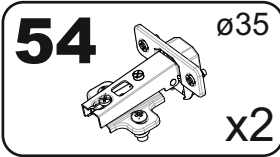
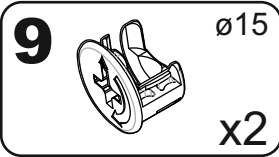
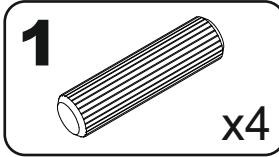

3

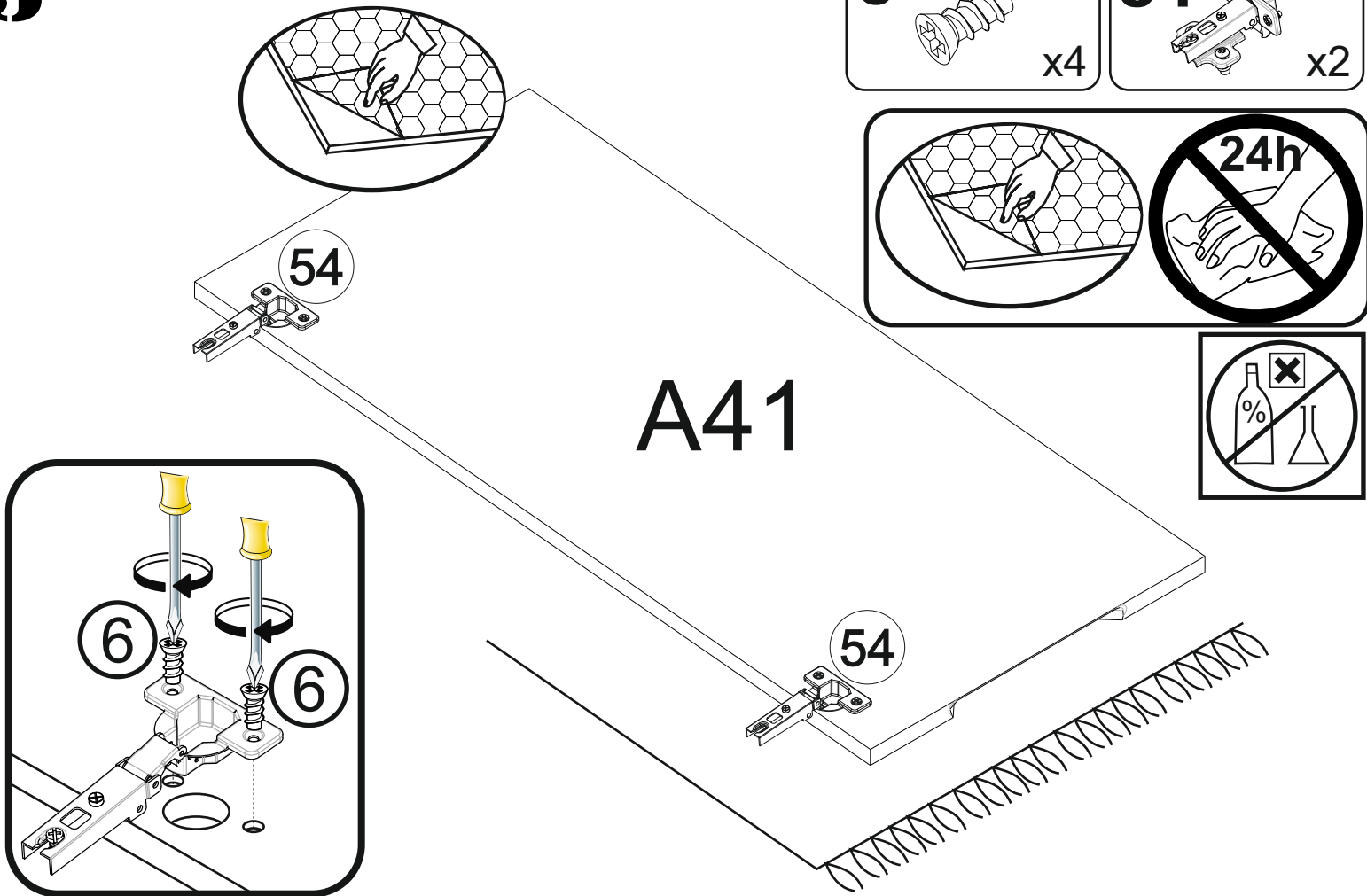

4

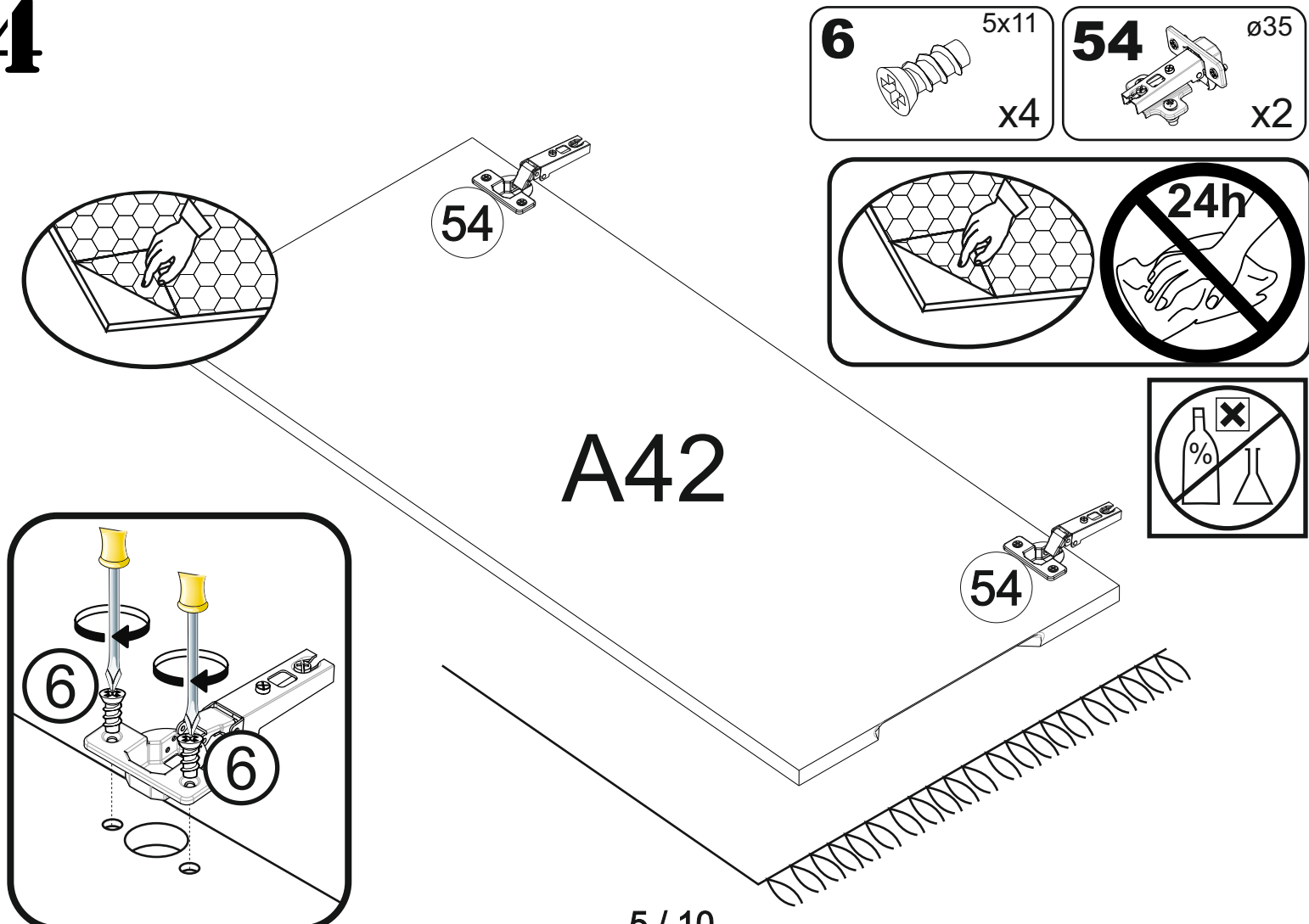

5

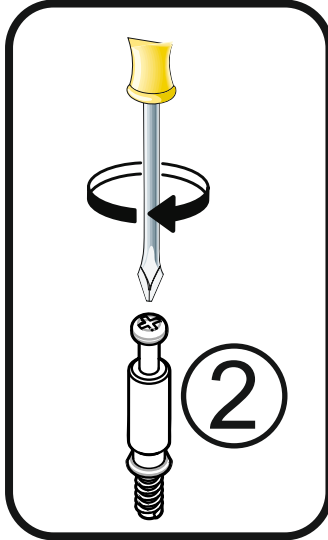
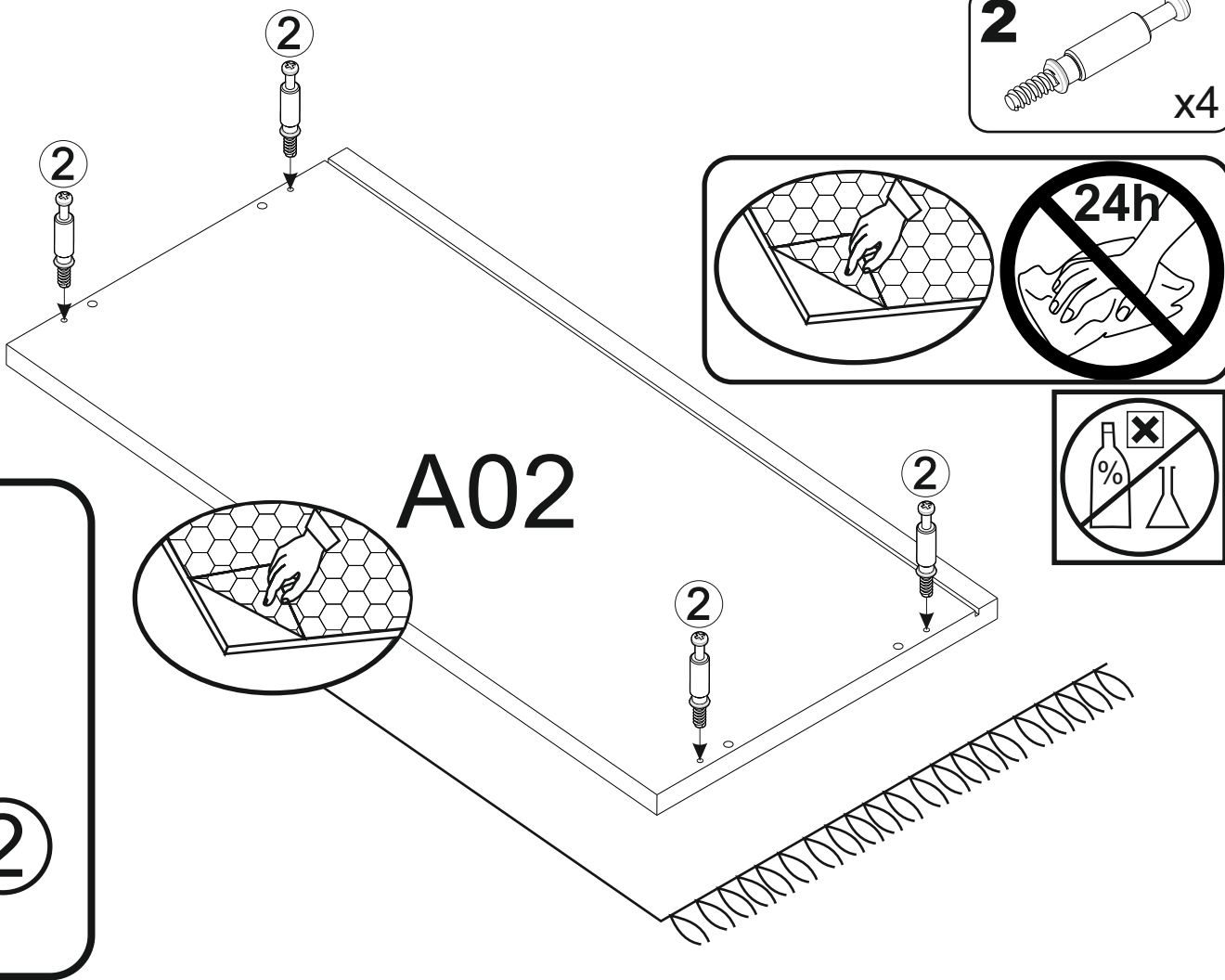

6

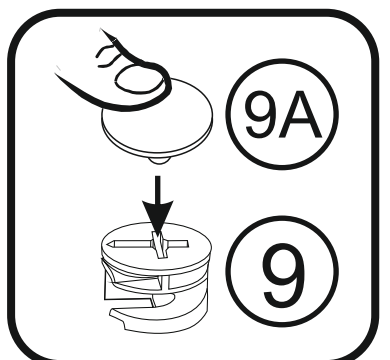
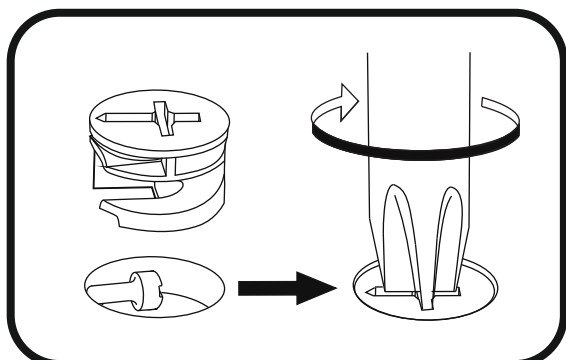
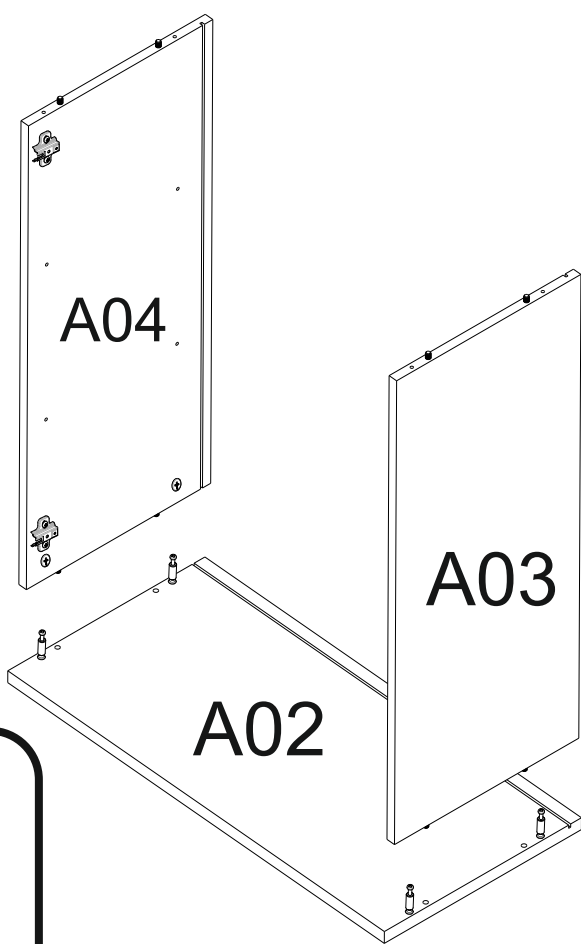

7

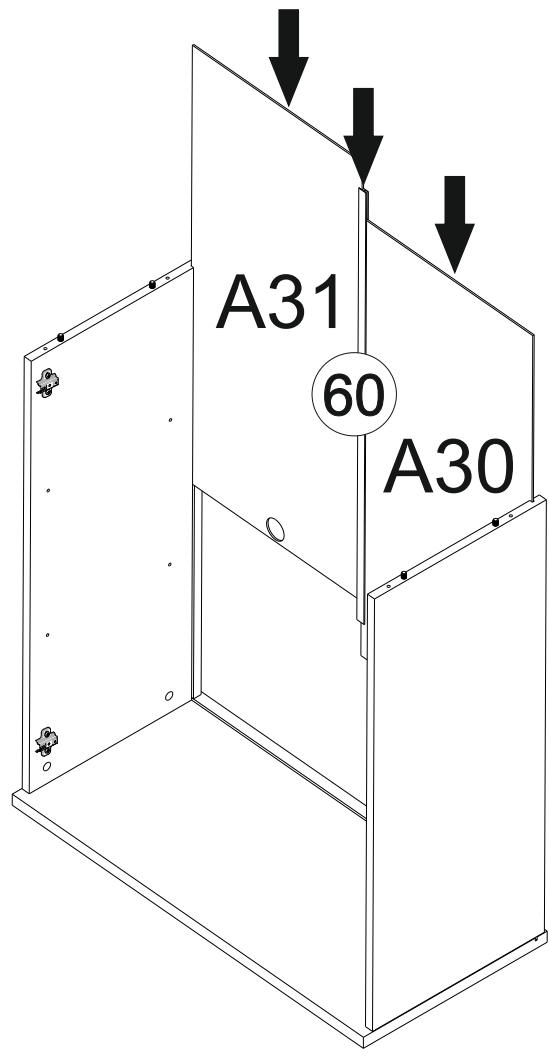
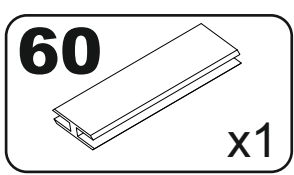

8

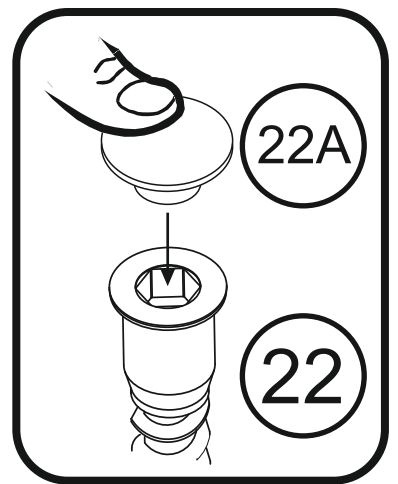
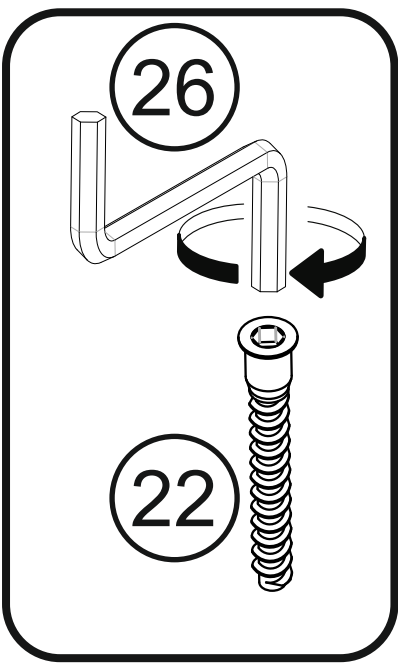
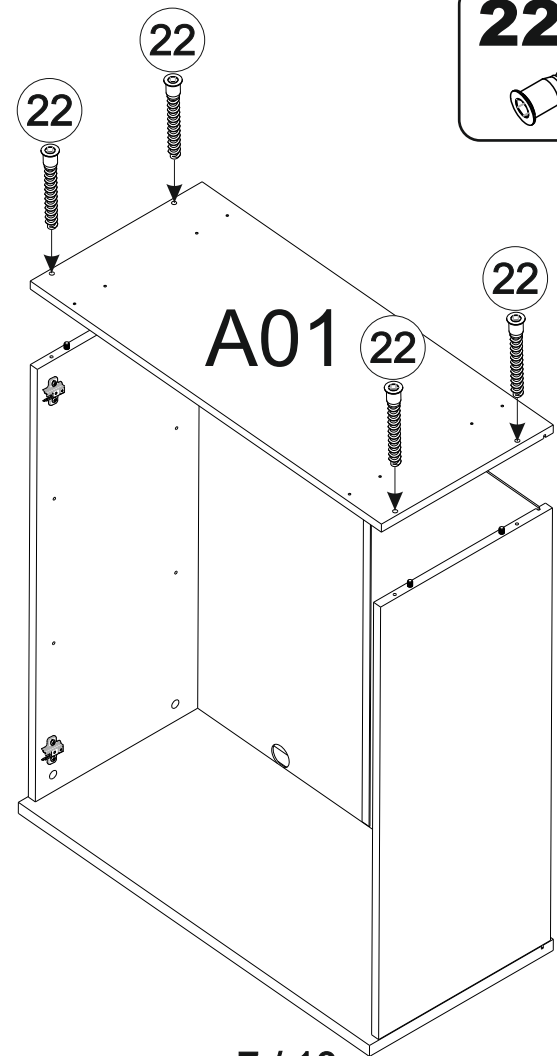
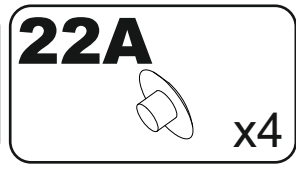
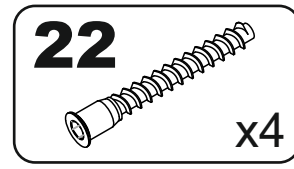

9

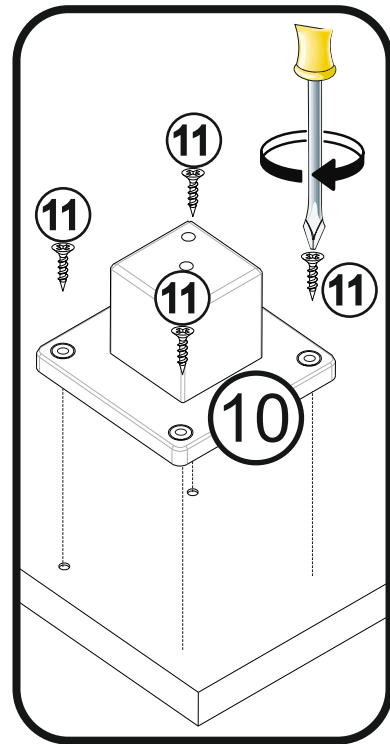
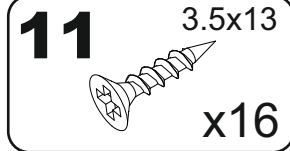
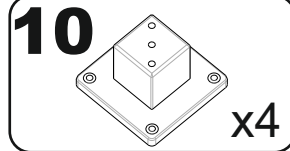
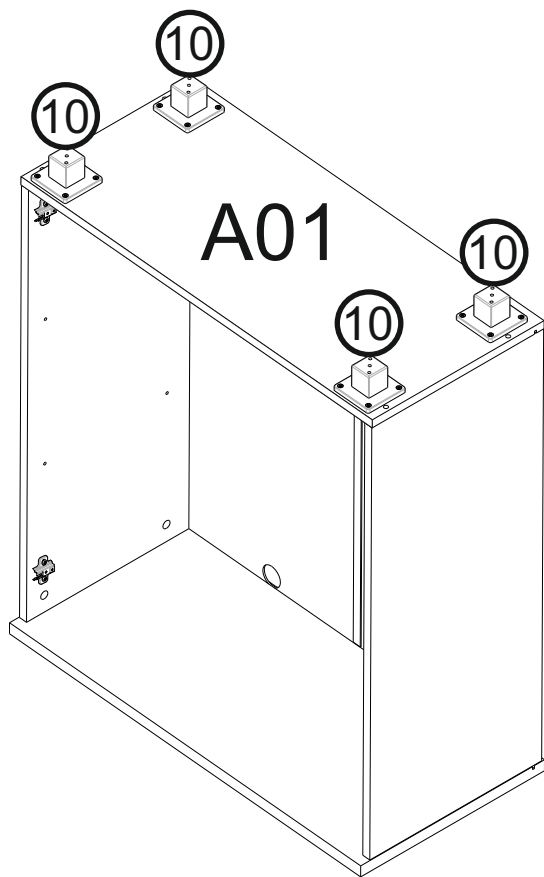

10

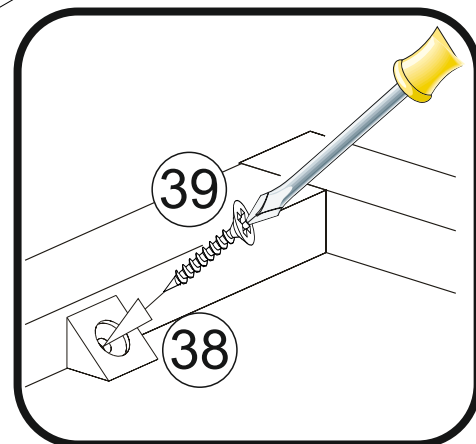
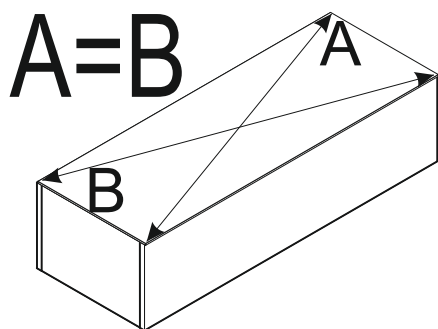
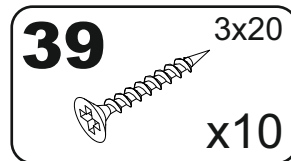
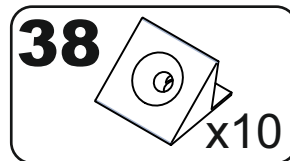
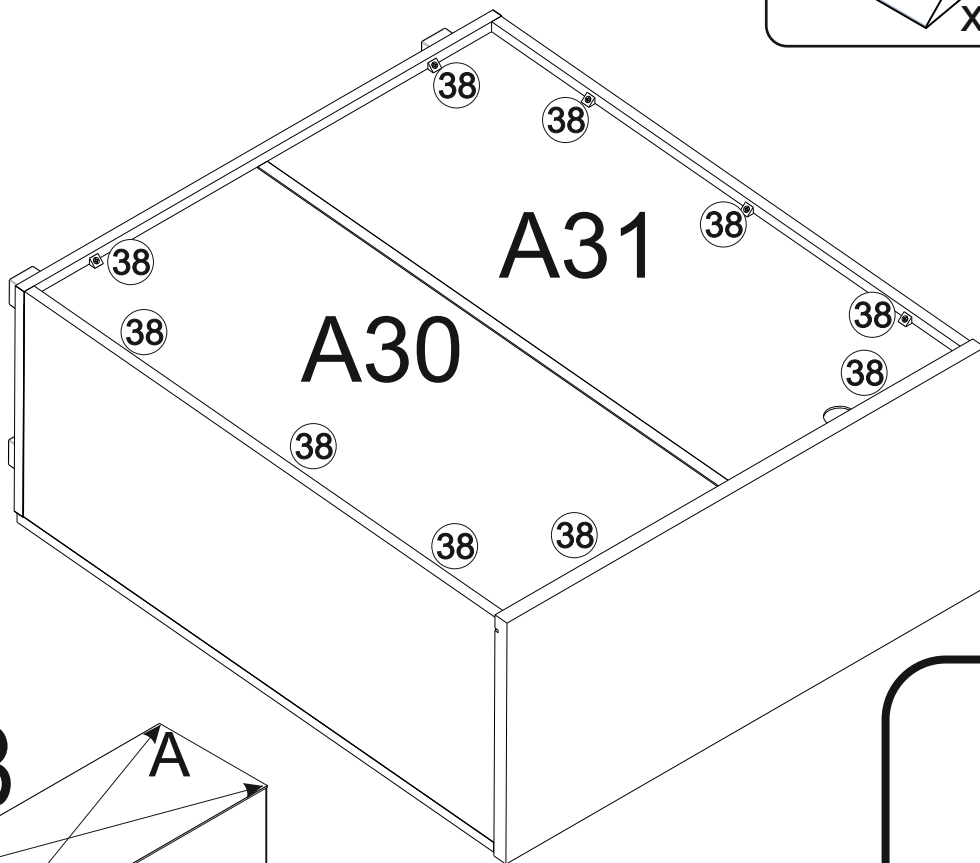

11

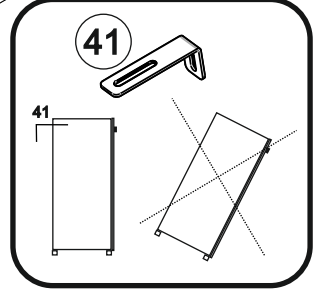
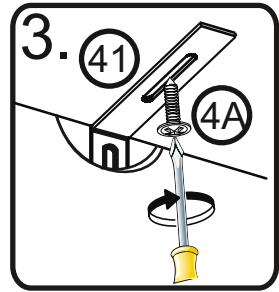
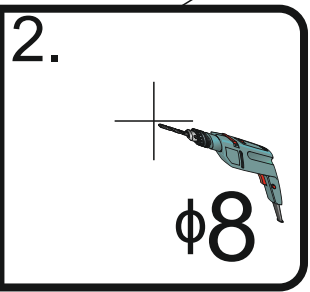
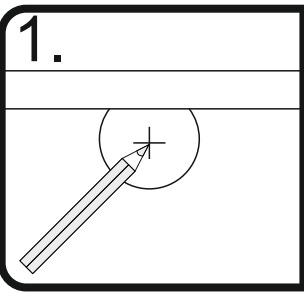
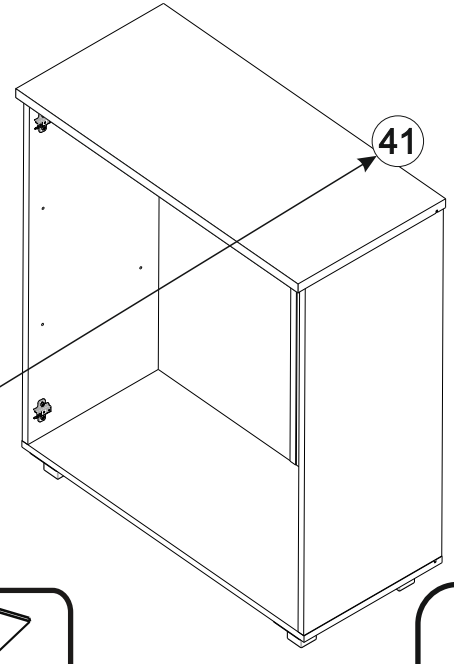
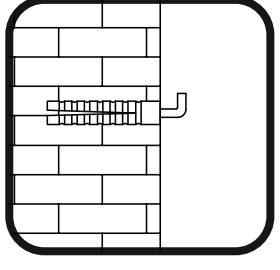
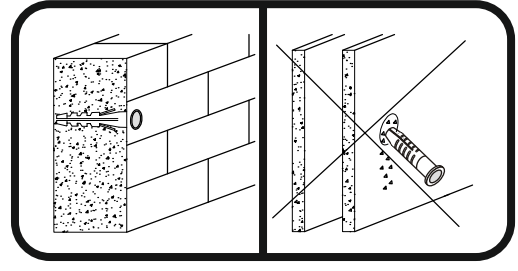
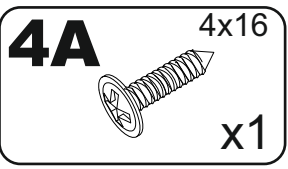
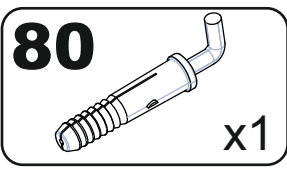
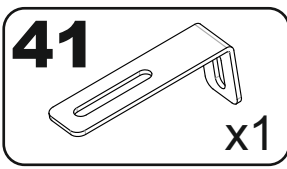

12

