

2X

50 MIN

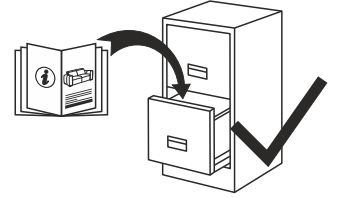
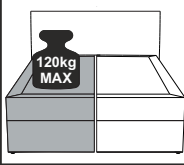
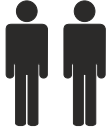

MODEL

“FINCA I PB BK”

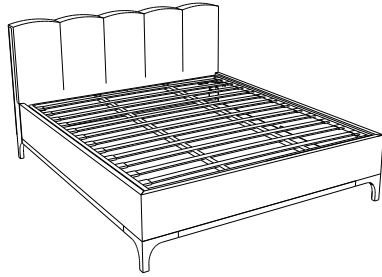



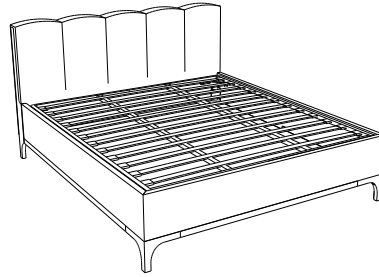





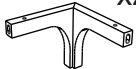

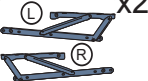







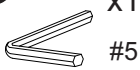

160x200



180x200

1/13

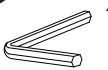
A  x2	B  x2 22x4,5x4,5 cm	C  x2	D  x4	E  x8 M6x55	F  x4	G  x4	H  x30 M6x30	I  x2
J  x8 M8	K  x1 20x4,5x4,5 cm	L  x2 5X30	M  x26 M6	N  x1 #5	O  x1	P  x7 22mm	Q  x8 M8x40	
Y  x4	R  x8 M8	S  x8 M8x25	T  x4 M6x45	U  x1 #4				

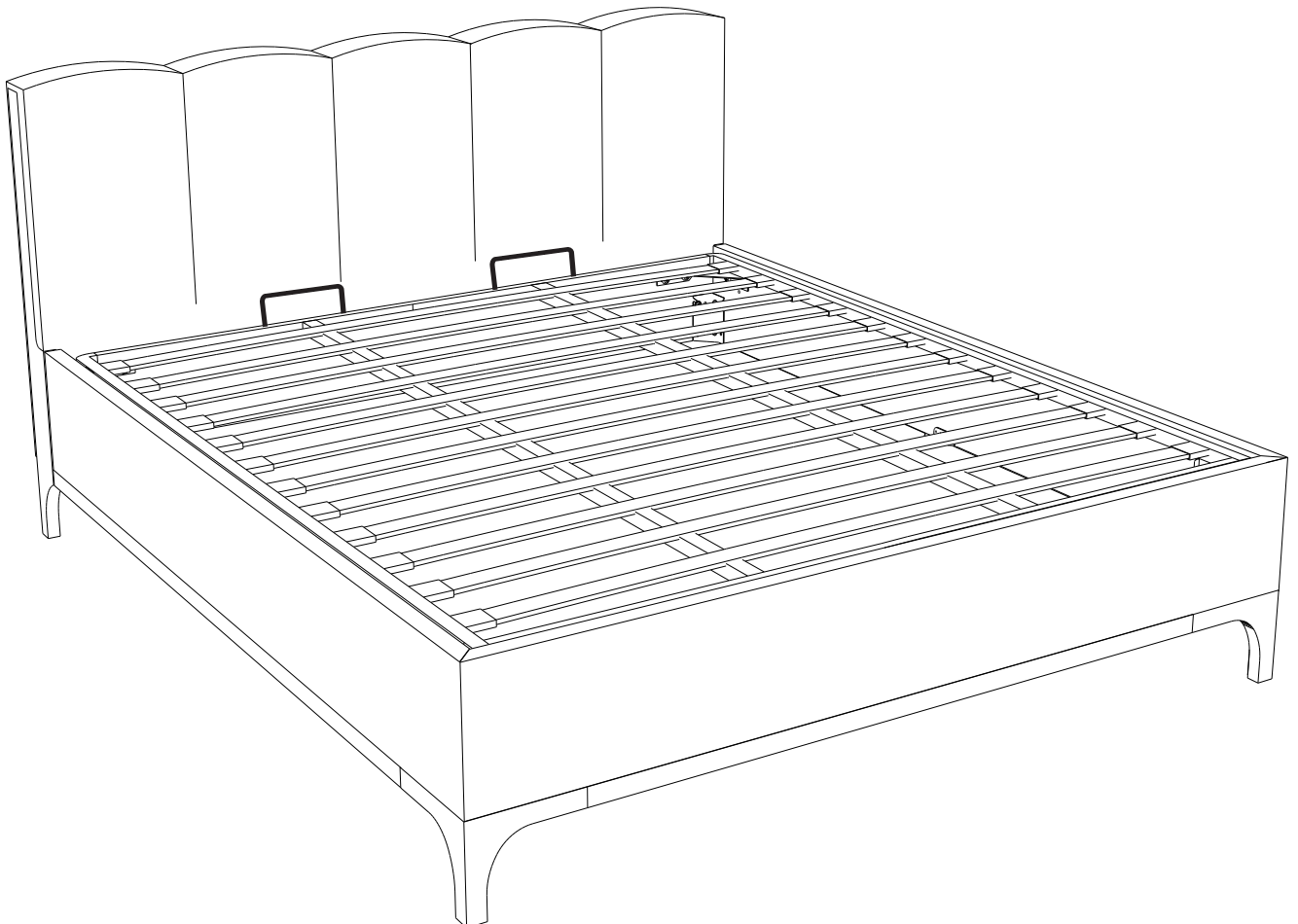
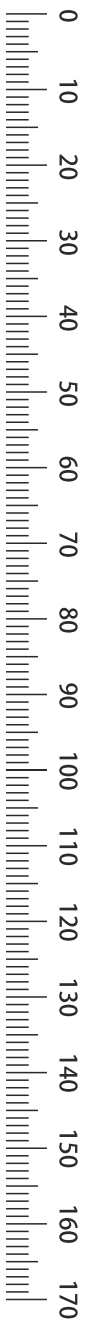

2X

50 MIN

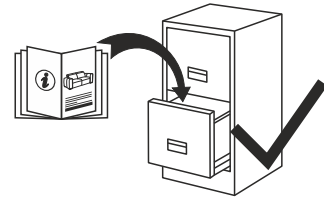
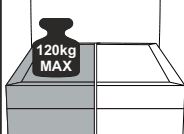

MODEL

“FINCA I PB BK”

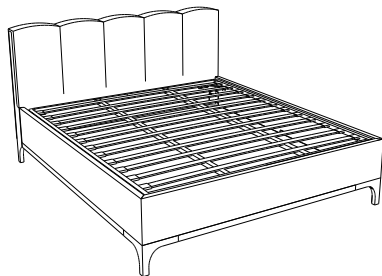

160x200

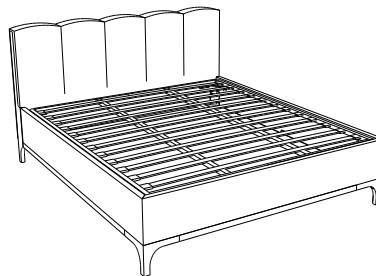

180x200

2/13

COLLI

PART

1/4

1+6+6+10

2/4

2+3+4+5+8

3/4

7

4/4

9+9

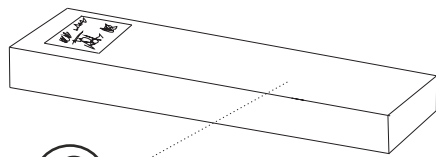
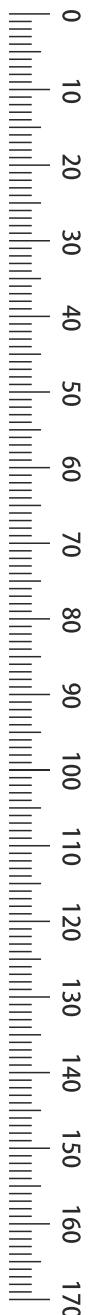

1

7

8

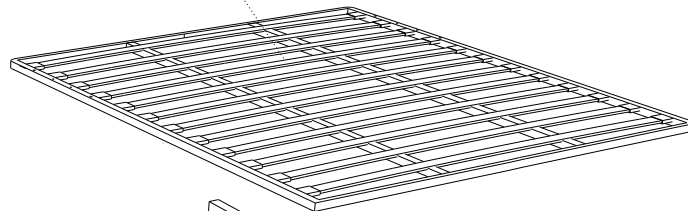
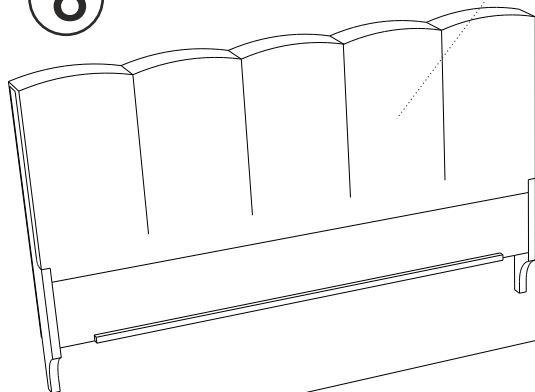

2

6

5

3

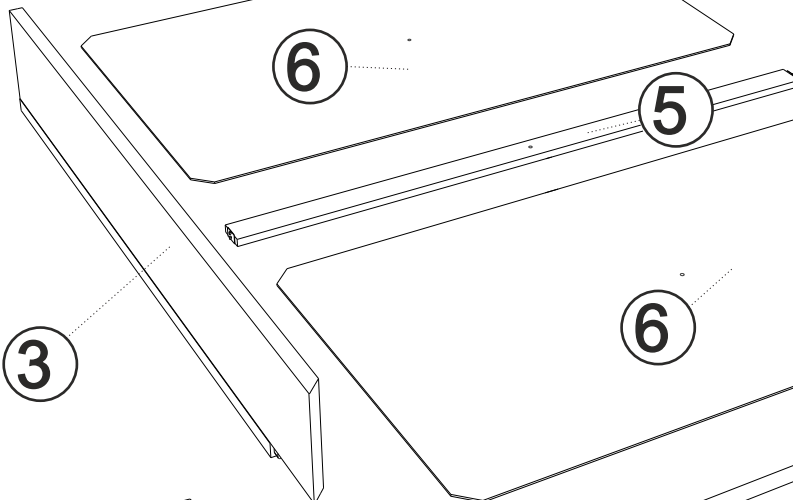

4

6

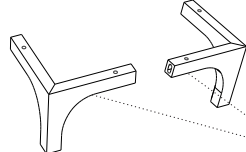

9

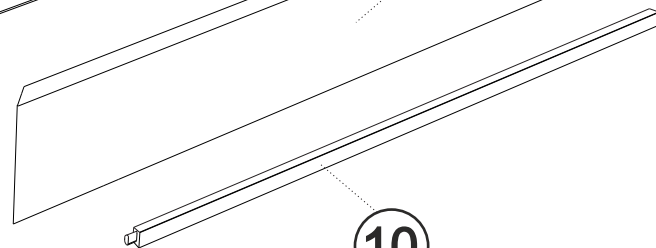

10

2X

50 MIN

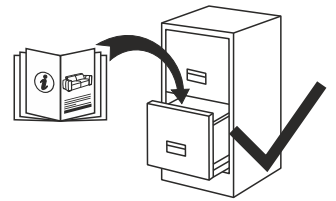
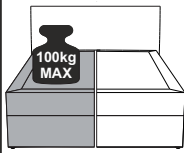

MODEL

“FINCA I PB BK”





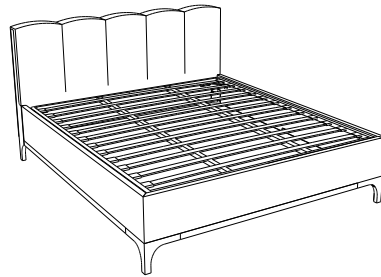



160x200



180x200

3/13

T  x4 M6x45	P  x2 22mm	G  x2	M  x4 M6	H  x8 M6x30	J  x8 M8
--	---	---	---	--	---

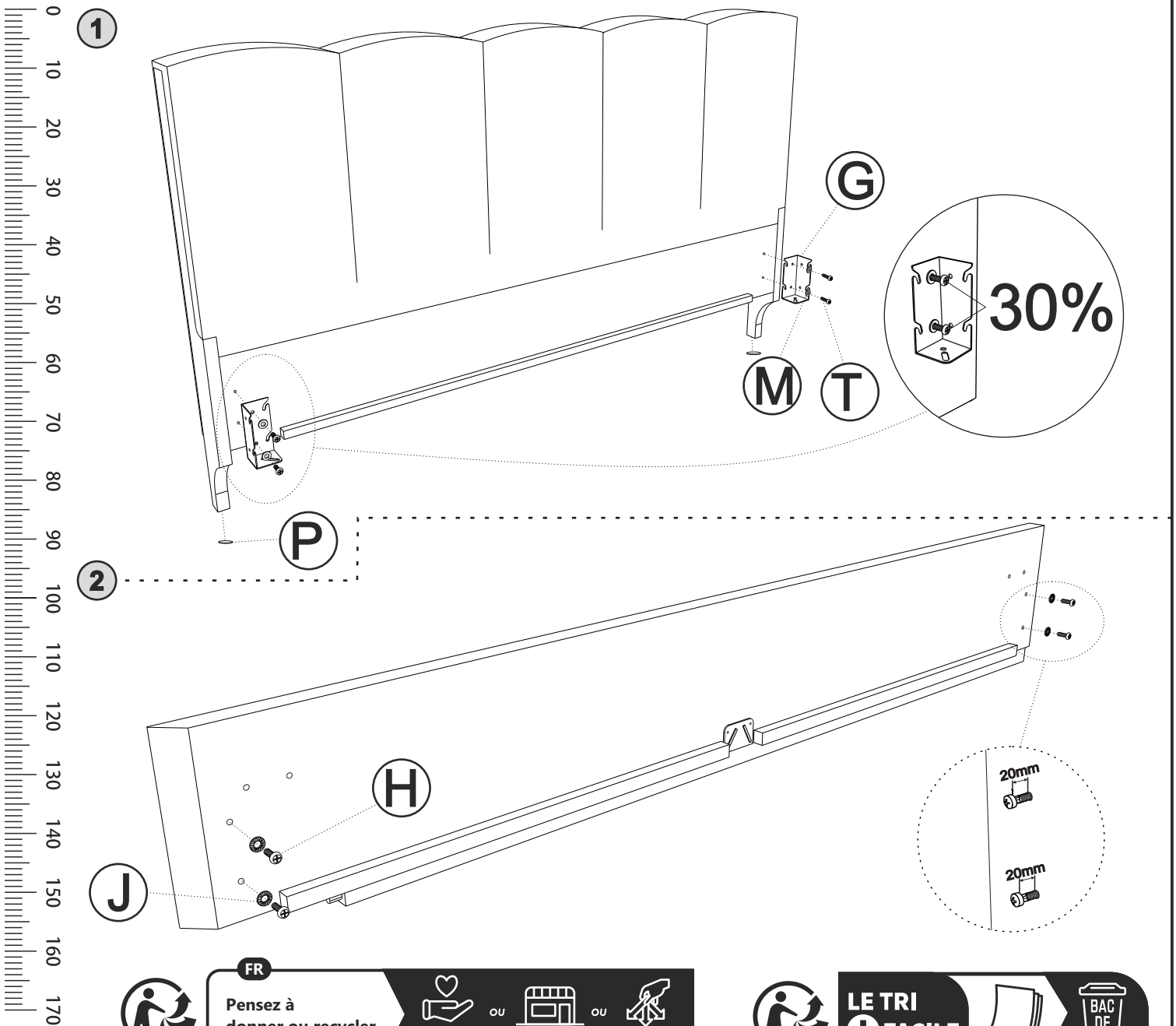

FR
Pensez à donner ou recycler.



ou



ou



<https://quefairedemesdechets.fr>



LE TRI + FACILE



BAC DE TRI

2X

50 MIN

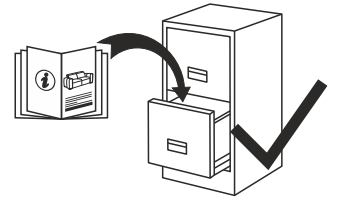
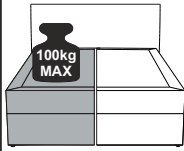

MODEL

“FINCA I PB BK”

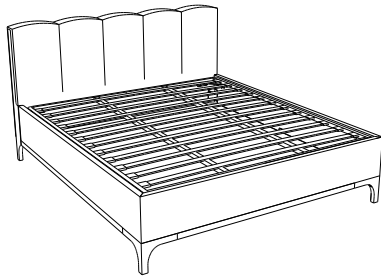

160x200

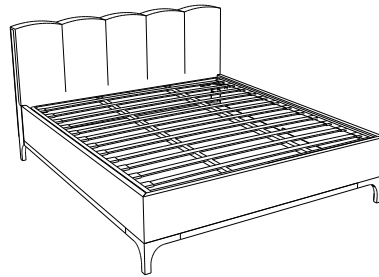

180x200

4/13

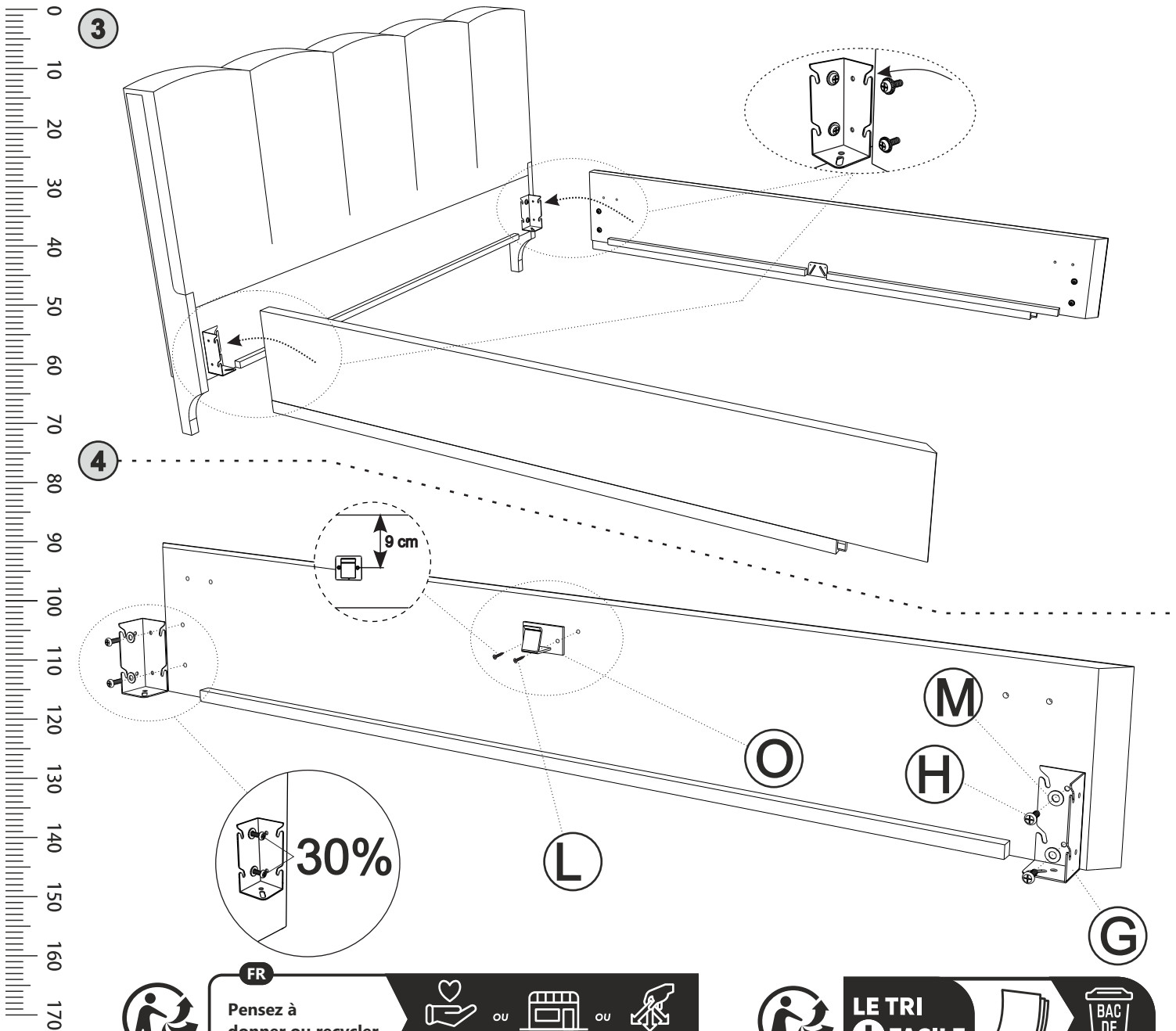
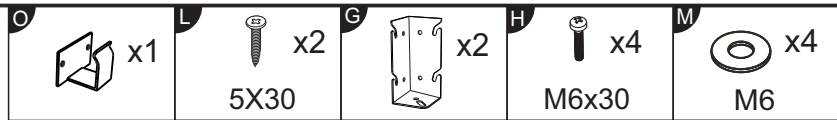

FR

Pensez à donner ou recycler.



ou



ou



Déchèterie



LE TRI + FACILE



BAC DE TRI

2X

50 MIN

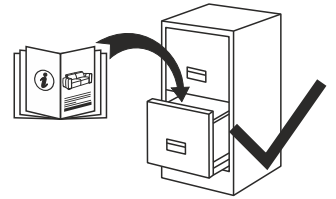
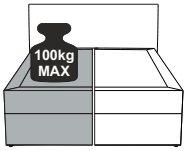

MODEL

“FINCA I PB BK”

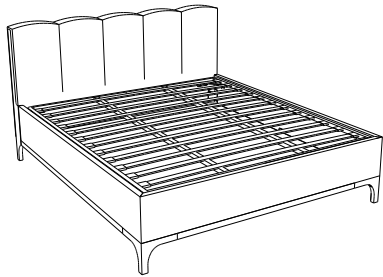

160x200

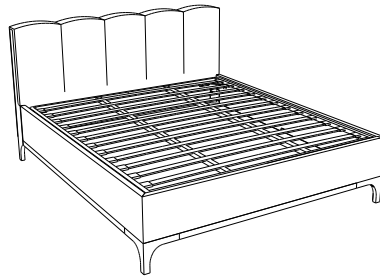

180x200

5/13

5

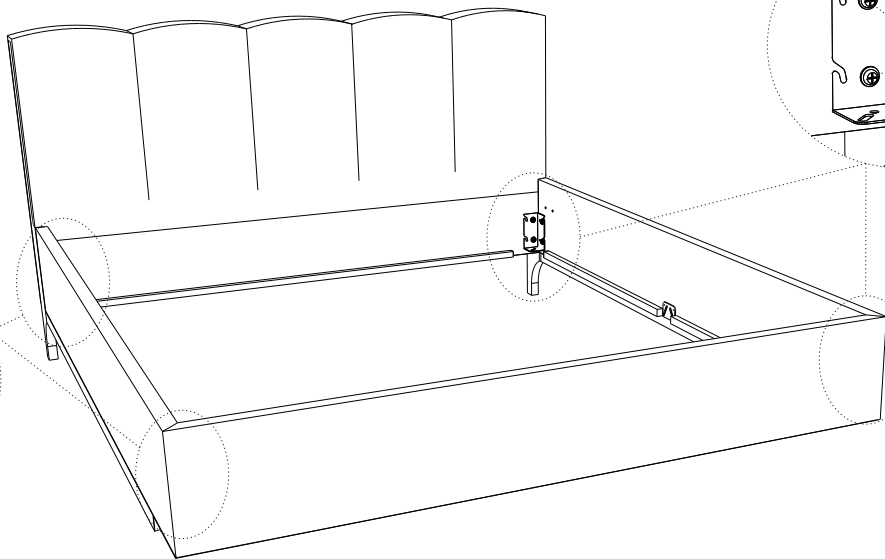
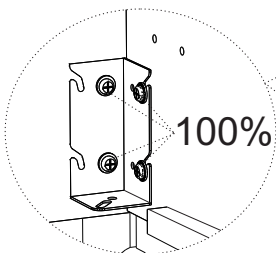
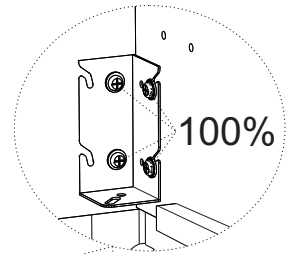
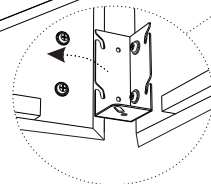
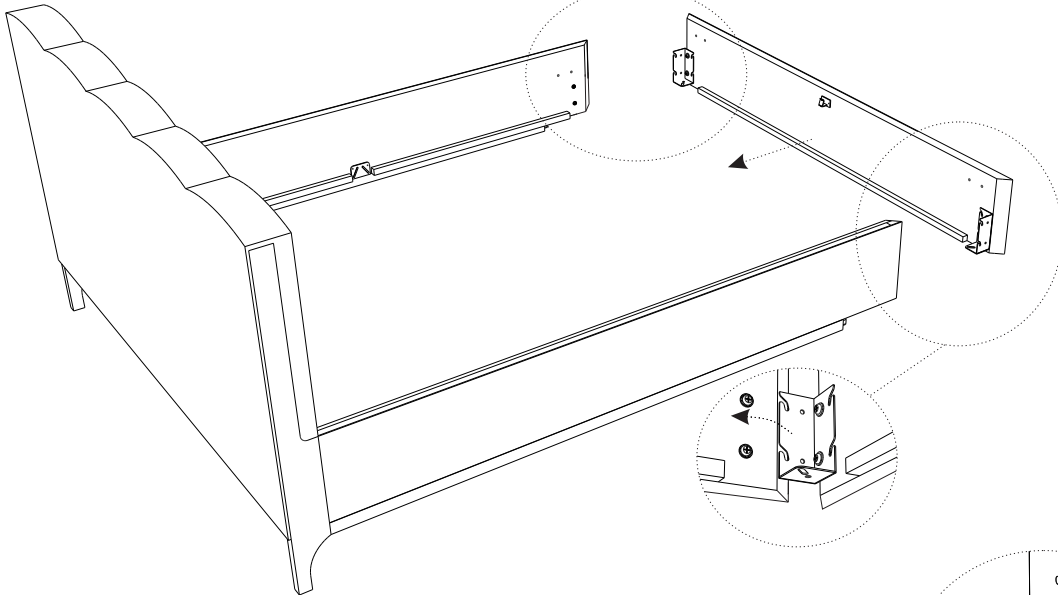

FR

Pensez à donner ou recycler.



ou



ou



Association

Magasin

Déchèterie



LE TRI + FACILE



2X

50 MIN

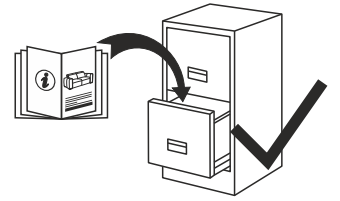
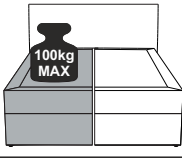

MODEL

“FINCA I PB BK”

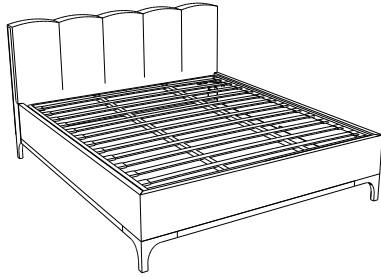

160x200

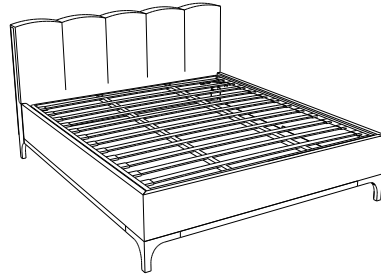

180x200

6/13

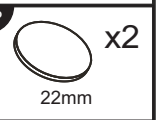
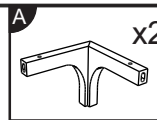

6

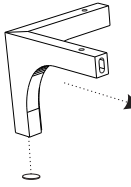

10

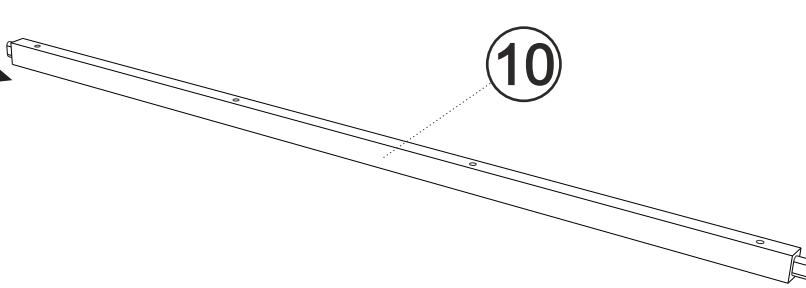

A

E

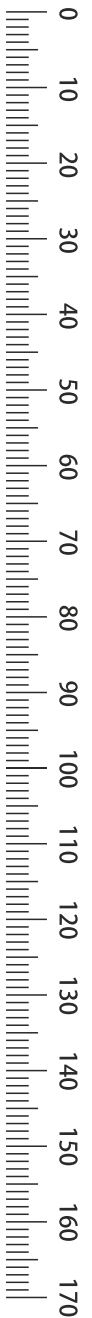
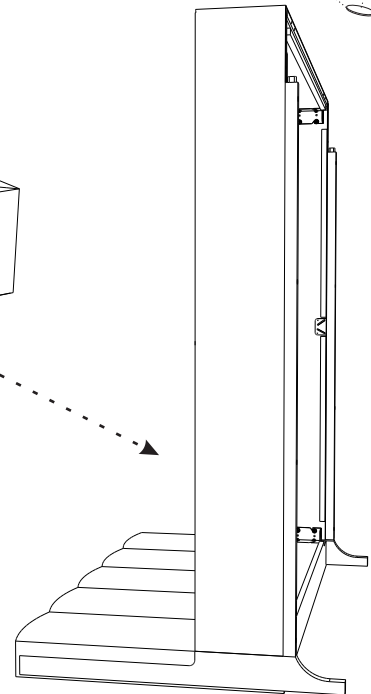
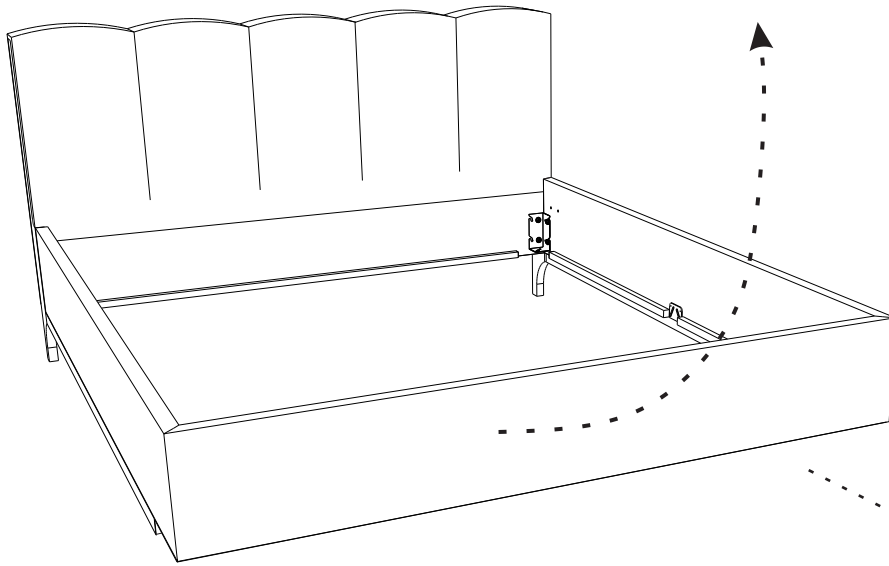
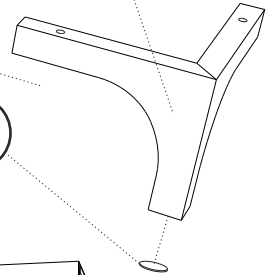

FR

Pensez à donner ou recycler.



ou



ou



Association Magasin Déchèterie



LE TRI + FACILE



2X

50 MIN

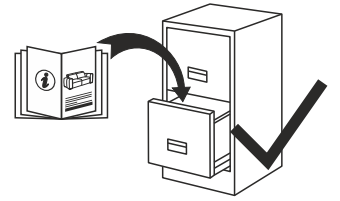
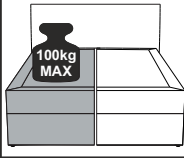

MODEL

“FINCA I PB BK”



160x200

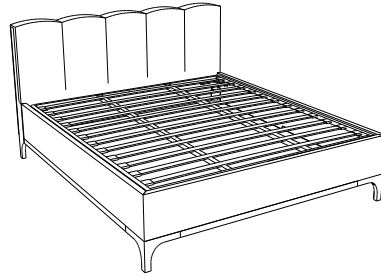

180x200

7/13

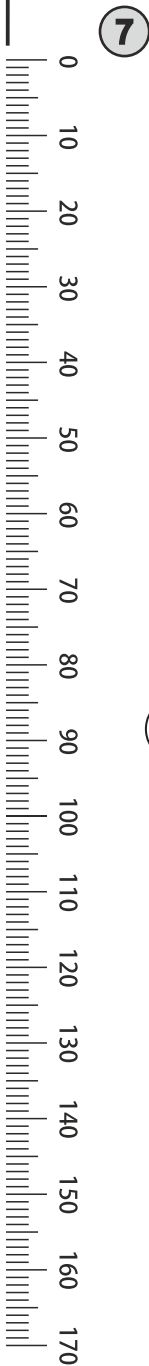
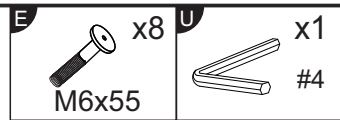

7

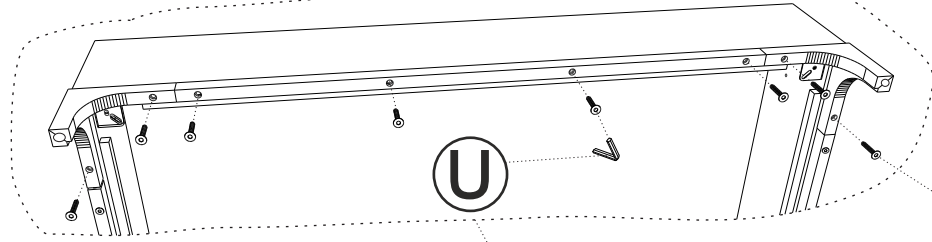

1.

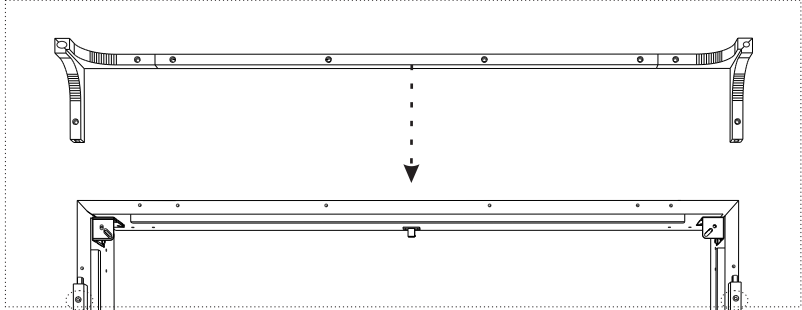

2.

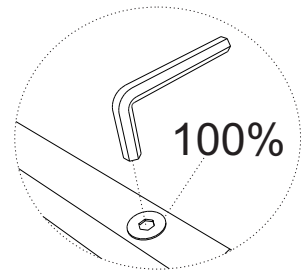
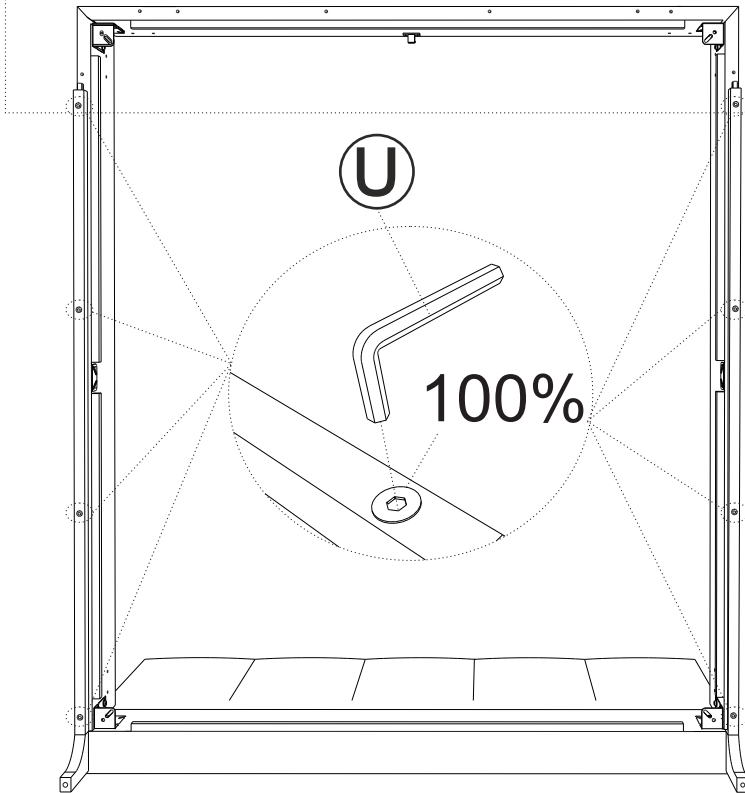

FR
Pensez à donner ou recycler.



ou



ou



Association Magasin Déchèterie



LE TRI + FACILE



2X

50 MIN

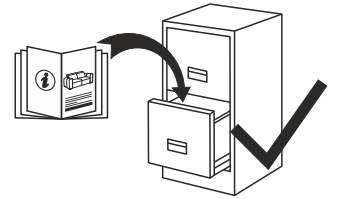
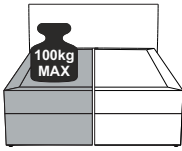

MODEL

“FINCA I PB BK”

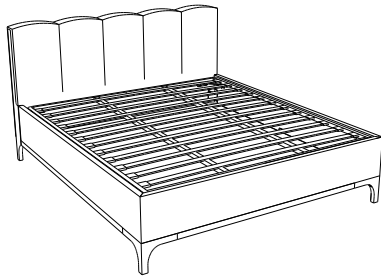

160x200

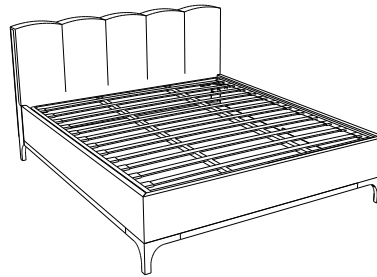

180x200

8/13

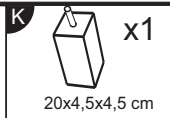
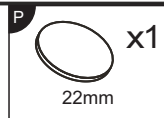

8

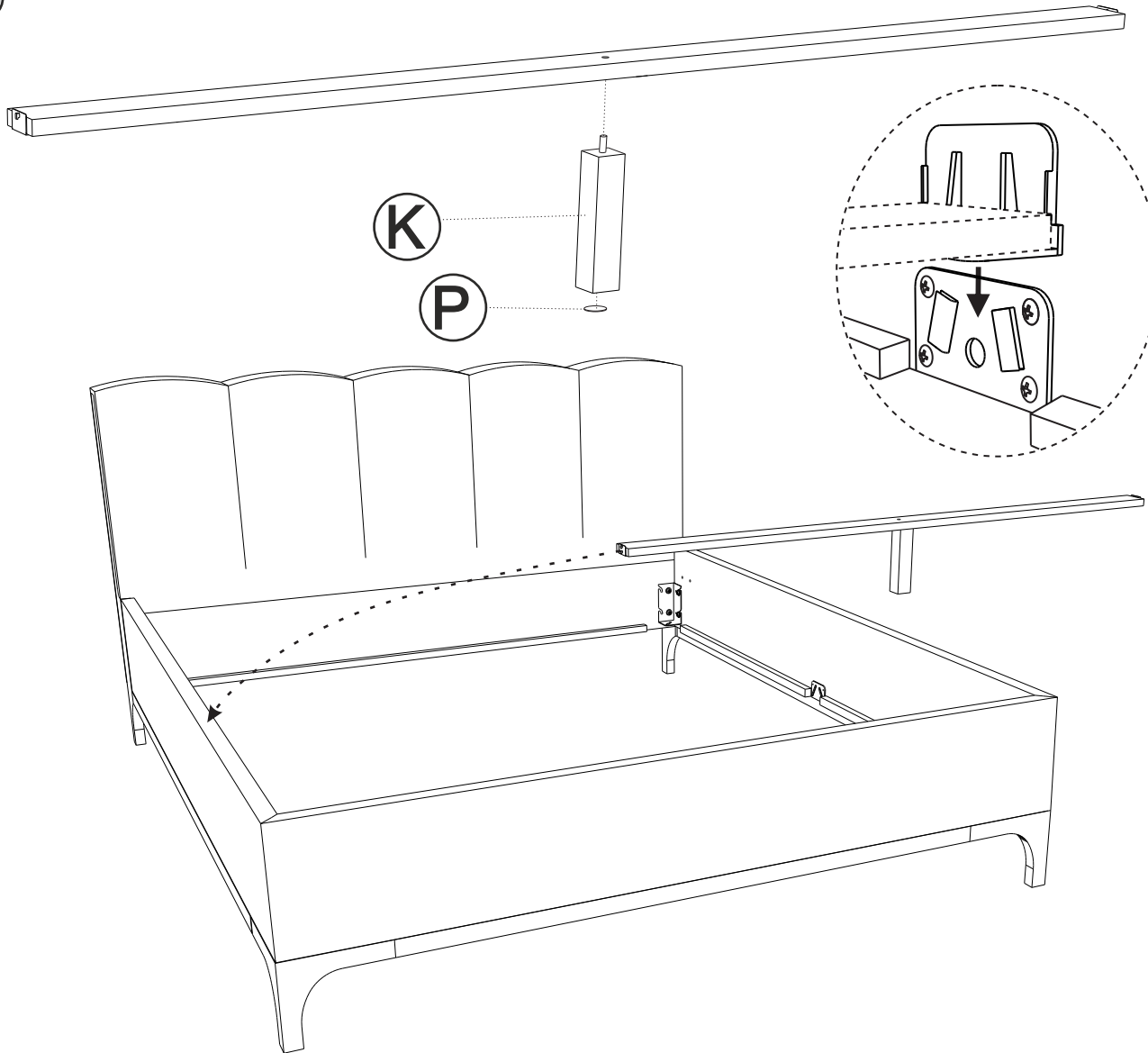

FR

Pensez à donner ou recycler.



ou



ou



Association Magasin Déchèterie



LE TRI + FACILE



2X

50 MIN

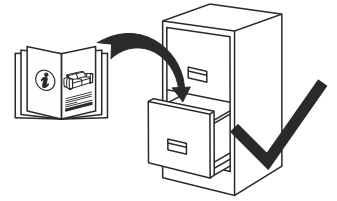
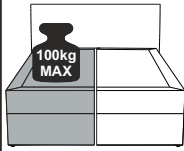

MODEL

“FINCA I PB BK”

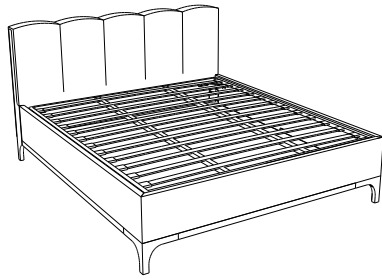

160x200

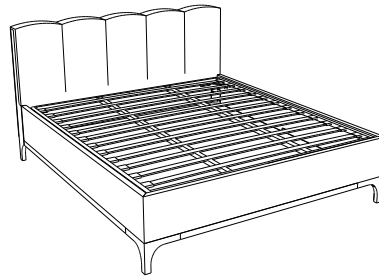

180x200

9/13

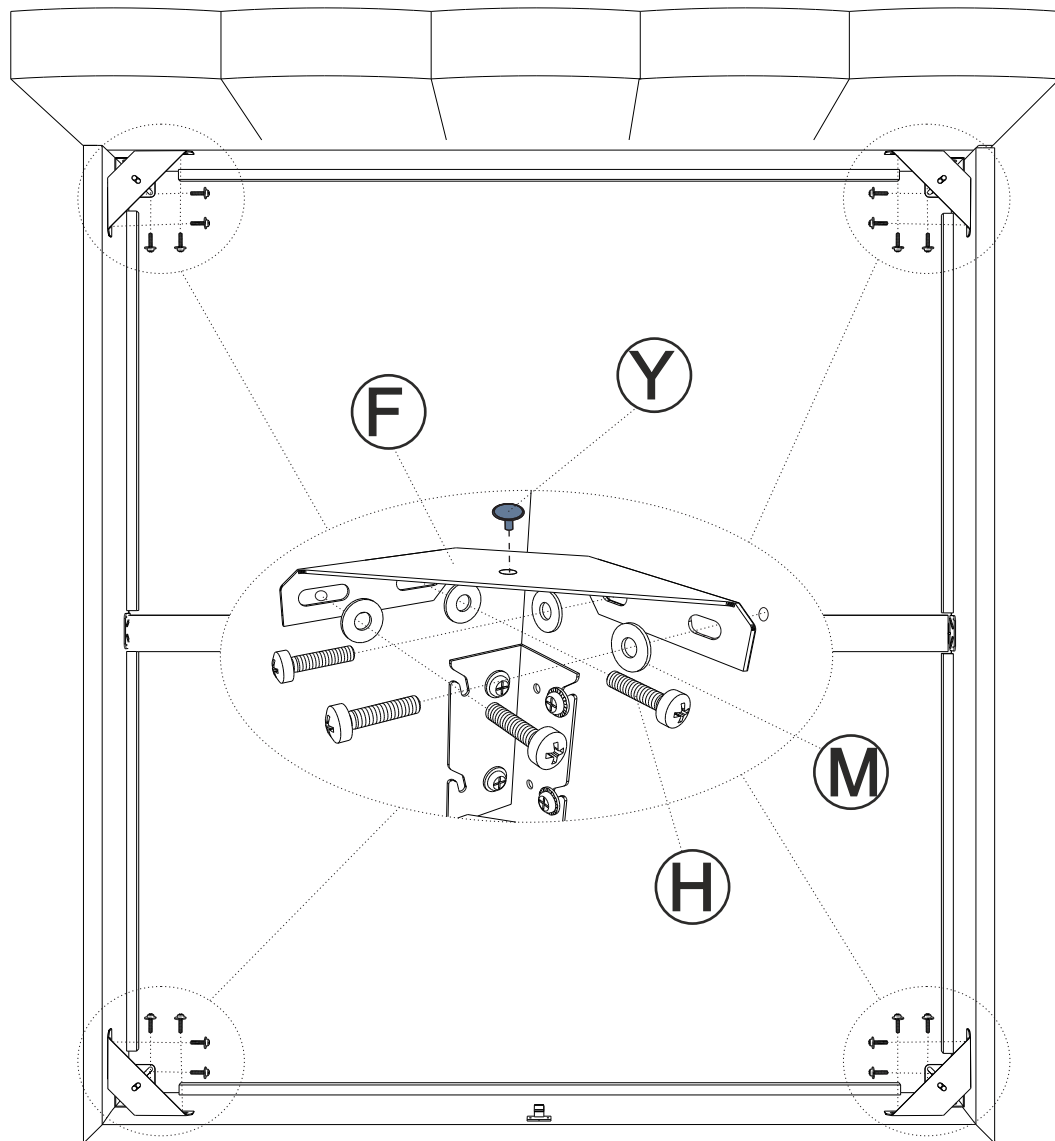
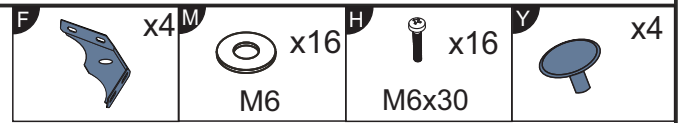

FR

Pensez à donner ou recycler.



ou



ou



Déchèterie



LE TRI + FACILE



2X

50 MIN

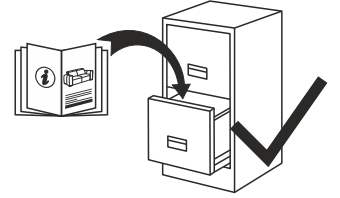
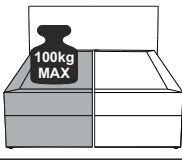

MODEL

“FINCA I PB BK”

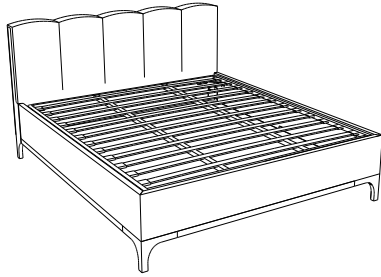

160x200



180x200

10/13

B	x2 22x4,5x4,5 cm	P	x2 22mm	M	x2 M6	H	x2 M6x30
----------	---------------------	----------	------------	----------	----------	----------	-------------

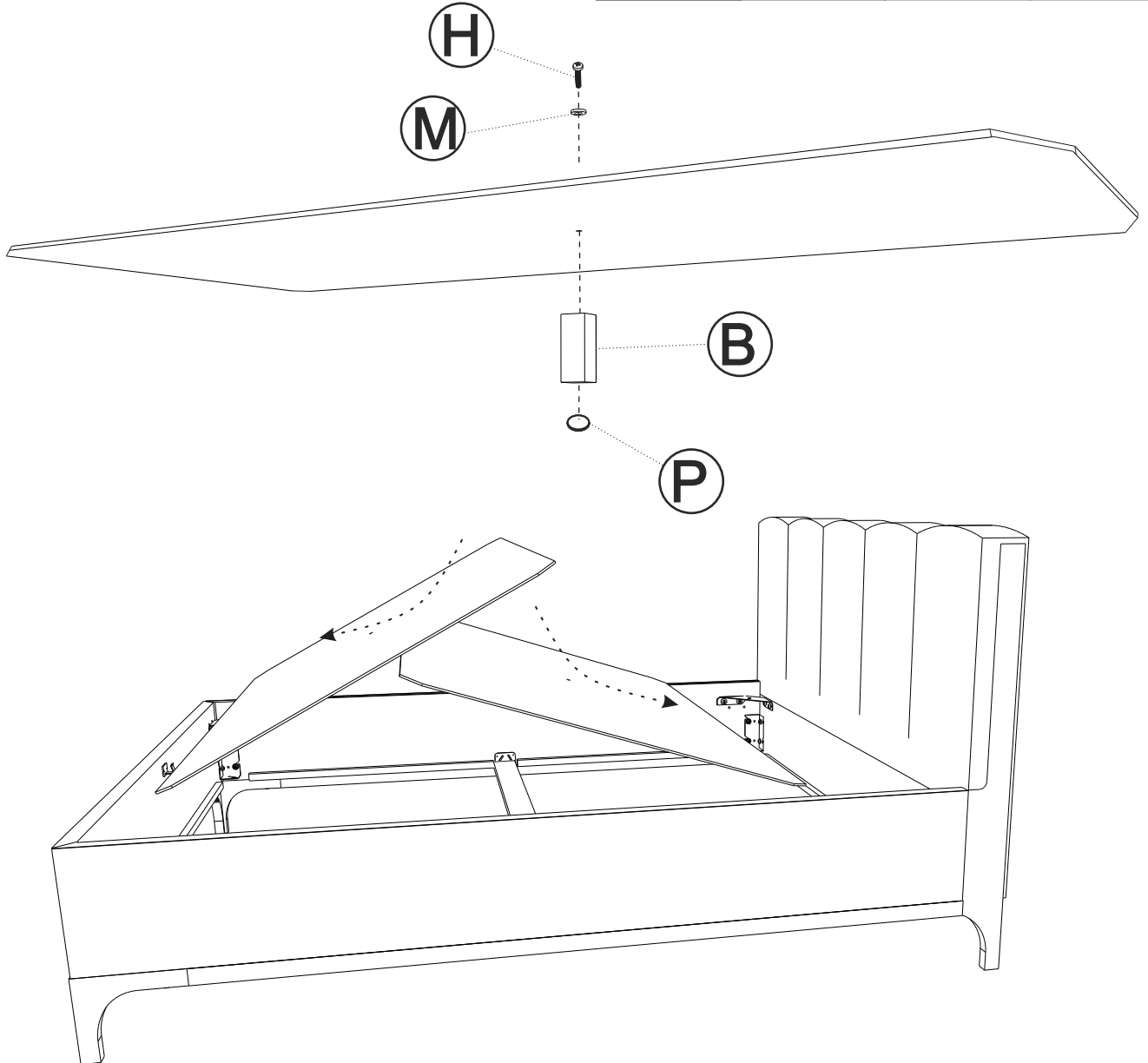

FR

Pensez à donner ou recycler.



ou



ou



Déchèterie



LE TRI + FACILE



2X

50 MIN

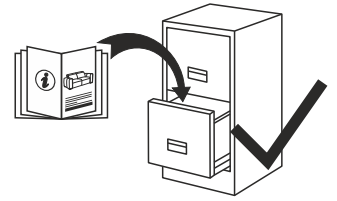
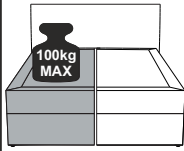
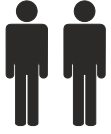

MODEL

“FINCA I PB BK”

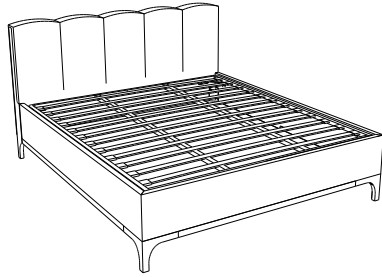

160x200



180x200

11/13

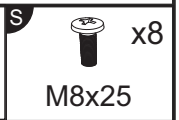
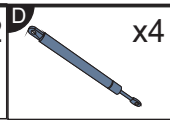
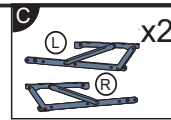

11

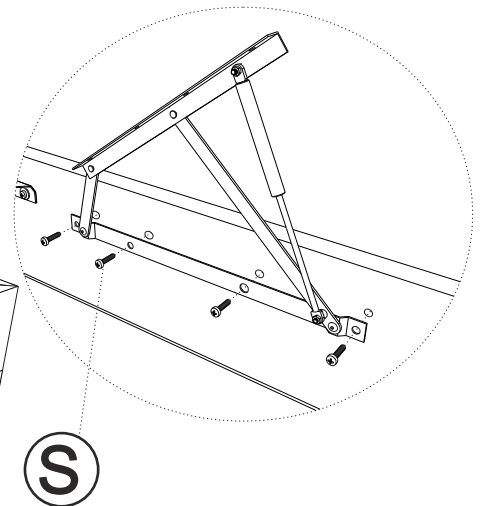
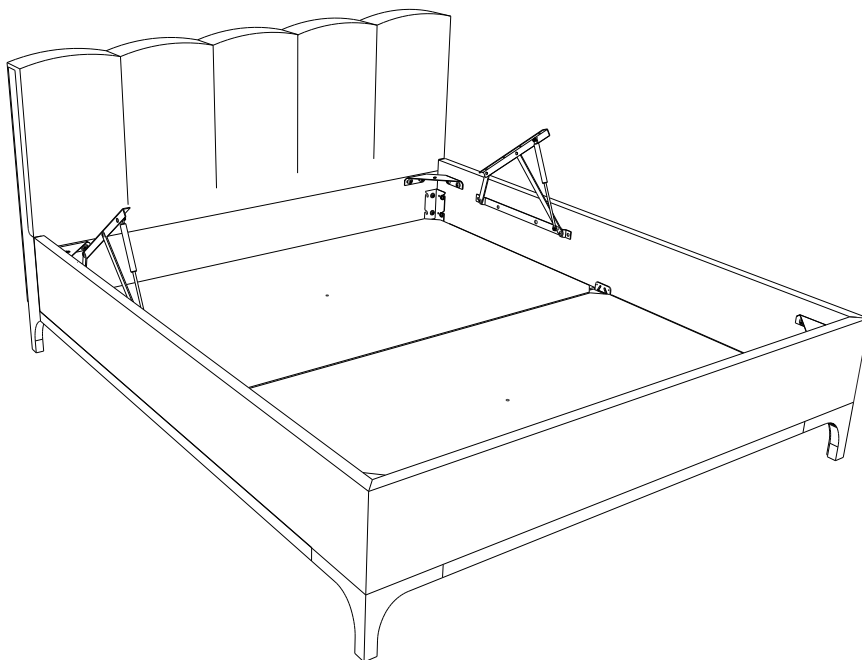
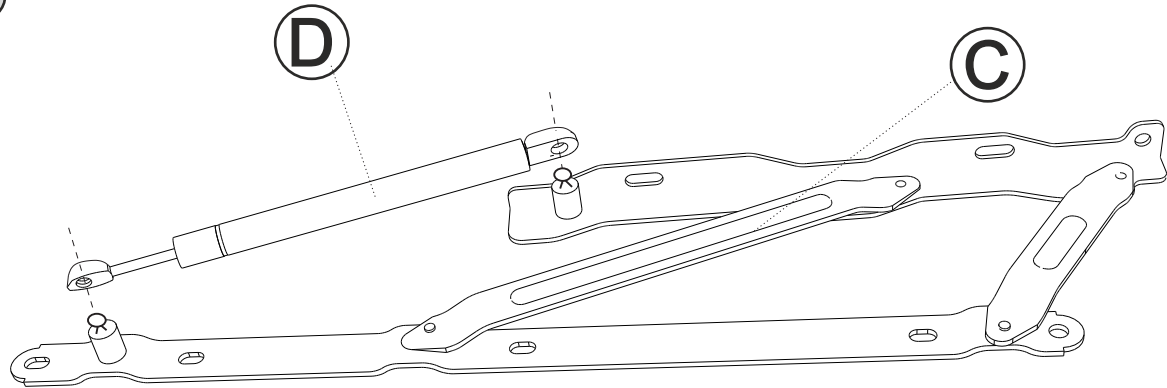

FR

Pensez à donner ou recycler.



ou



ou



Association Magasin Déchèterie



LE TRI + FACILE



2X

50 MIN

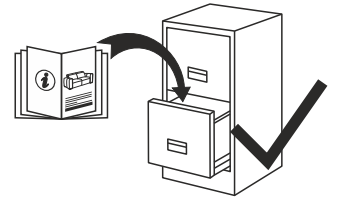
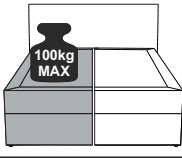
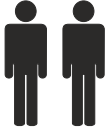

MODEL

“FINCA I PB BK”

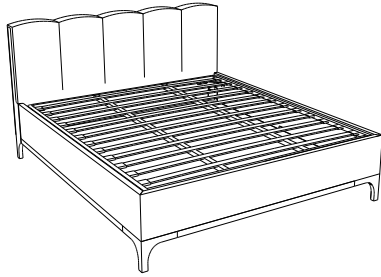

160x200



180x200

12/13

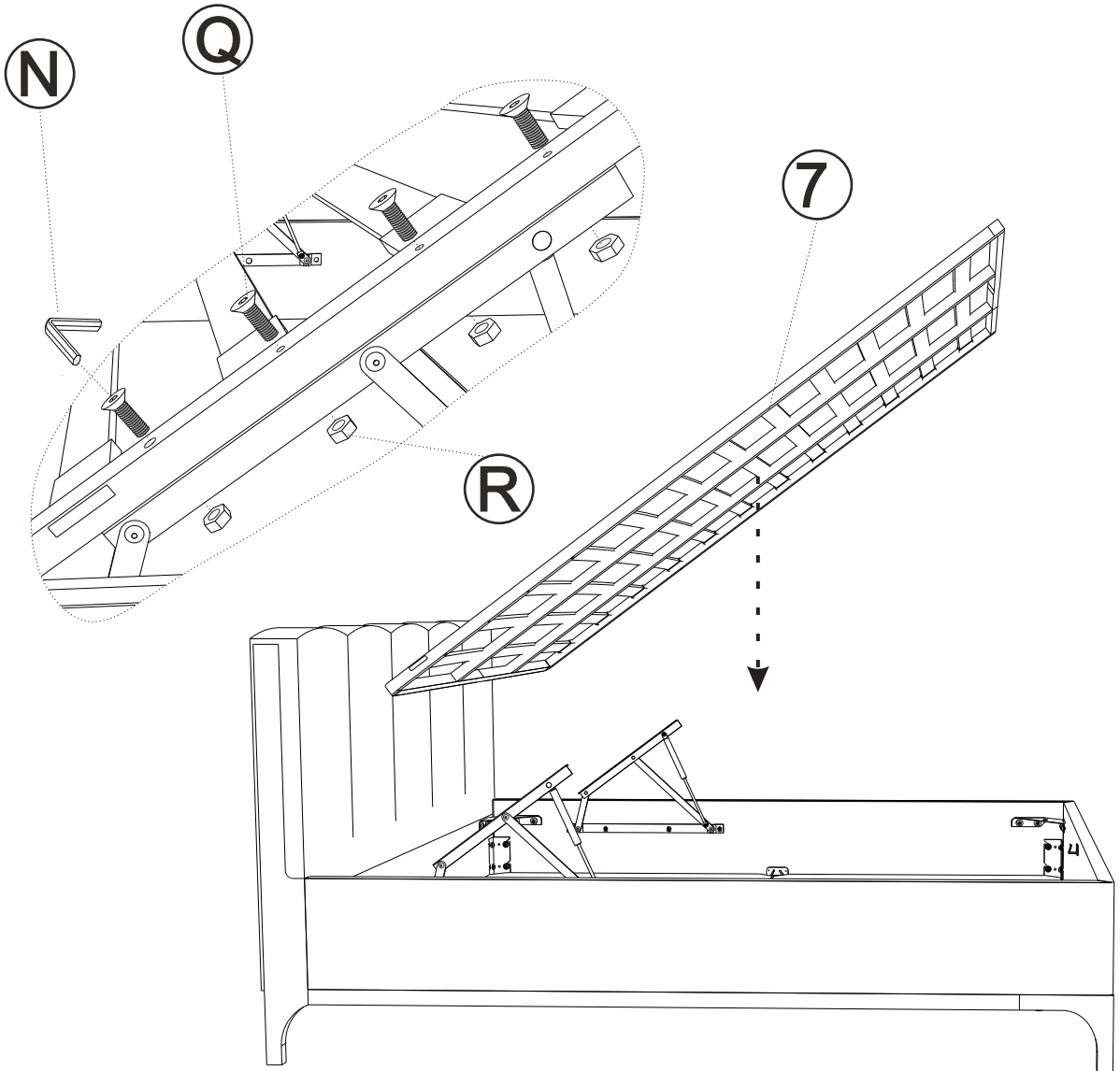
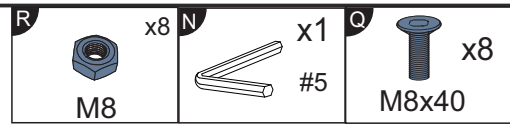

FR

Pensez à donner ou recycler.



ou



ou



Déchèterie



LE TRI + FACILE



BAC DE TRI

2X

50 MIN

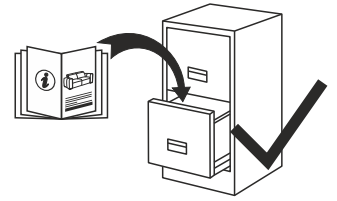
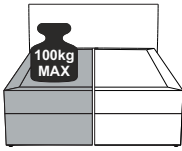
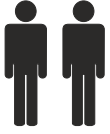

MODEL

“FINCA I PB BK”

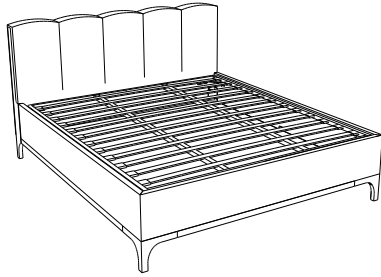

160x200



180x200

13/13

x2



13

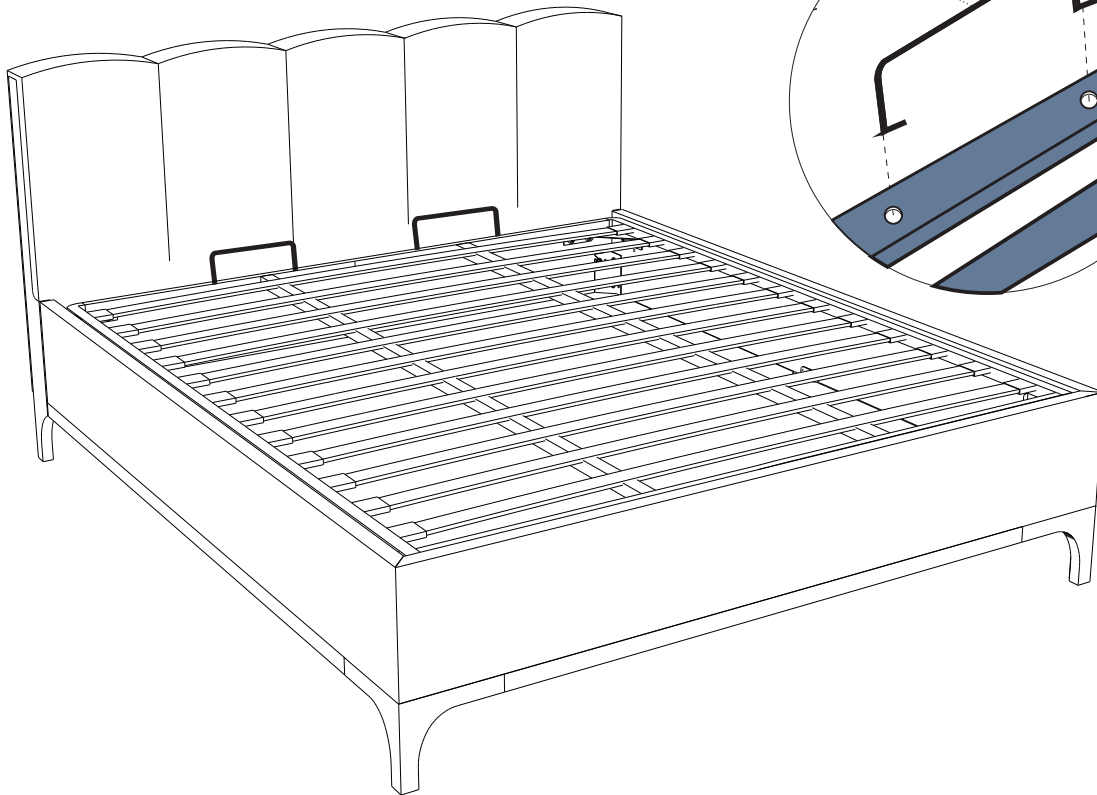

FR

Pensez à donner ou recycler.



ou



ou



Association Magasin Déchèterie



LE TRI + FACILE



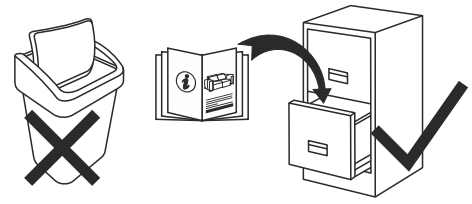

GB IMPORTANT!- Relocate the bed after final assembling solely with uplifted support legs, in order to avoid damages on substructure or flooring. Consider correct height adjustment of support legs afterwards settling the bed in final position. Disassemble the bed prior to move to a new location.

DE WICHTIG!- Bewegen Sie das Bett nach der Endmontage nur mit hochgestellten Stützbeinen um Schäden an der Unterkonstruktion oder dem Fussboden zu vermeiden. Achten Sie auf die richtige Einstellung der Stützbeinhöhe, nachdem das Bett in der endgültigen Position platziert wurde. Zerlegen Sie das Bett, bevor Sie es an einen neuen Standort bringen.

FR IMPORTANT!- Déplacez le lit après l'assemblage final uniquement avec des pieds de support surélevés, afin d'éviter d'endommager la sous-structure ou le sol. Envisagez un réglage correct de la hauteur des pieds de support après avoir installé le lit en position finale. Démontez le lit avant de le déplacer vers un nouvel emplacement.

PL WAŻNE!- Przenieś łóżko po ostatecznym montażu wyłącznie z podniesionymi nogami podporowymi, aby uniknąć uszkodzeń konstrukcji nośnej lub podłogi. Rozważ prawidłową regulację wysokości nóg podporowych, a następnie ustaw łóżko w ostatecznej pozycji. Zdemontuj łóżko przed przeprowadzką w nowe miejsce.

DK VIGTIGT!- Flyt sengen efter den endelige montering udelukkende med løftede støtteben for at undgå skader på underkonstruktion eller gulv. Overvej korrekt højdejustering af støttebenene efter at have sat sengen i den endelige position. Skil sengen ad, inden du flytter til et nyt sted.

NO VIKTIG!- Flytt senga etter sluttmontering utelukkende med løfta støttebein, for å unngå skader på underkonstruksjon eller golv. Vurder riktig høydejustering av støttebeina etter at senga er sett i endelig posisjon. Demonter senga før du flytter til eit nytt stad.

SE VIKTIGT!- Flytta sängen efter slutmontering enbart med upphöjda stödben för att undvika skador på underkonstruktion eller golv. Tänk på korrekt höjdjustering av stödbenen efteråt och sätt sängen i slutläge. Ta isär sängen innan du flyttar till en ny plats.

FI TÄRKEÄÄ!- Siirrä sänky lopullisen kokoonpanon jälkeen yksinomaan kohotetuilla tukijaloilla, jotta vältetään alusrakenteen tai lattian vaurioituminen. Harkitse tukijalkojen oikeaa korkeuden säätöä sen jälkeen, kun sänky asetetaan lopulliseen asentoon. Pura sänky ennen muuttoa uuteen paikkaan.

CZ DŮLEŽITÉ!- Po konečné montáži přemístěte postel pouze se zvednutými podpěrnými nohami, aby nedošlo k poškození spodní konstrukce nebo podlahy. Zvažte správné výškové nastavení opěrných nohou po usazení postele do konečné polohy. Před přemístěním na nové místo postel rozeberte.

HU FONTOS!- A végső összeszerelés után helyezze át az ágyat kizárólag felemelt támasztólábakkal, hogy elkerülje az alépítmény vagy a padlózat károsodását. Fontolja meg a támasztólábak helyes magasságbeállítását, majd az ágy végső helyzetbe állítását. Szerelje szét az ágyat, mielőtt új helyre költözne.

NL BELANGRIJK!- Verplaats het bed na de definitieve montage uitsluitend met opgetilde steunpoten om schade aan de onderconstructie of vloer te voorkomen. Overweeg de juiste hoogteaafstelling van de steunpoten nadat u het bed in de definitieve positie hebt gebracht. Demonteer het bed voordat u het naar een nieuwe locatie verplaatst.

SK DÔLEŽITÉ !- Po konečnej montáži postel' premiestnite výlučne so zdvihnutými opornými nohami, aby ste predišli poškodeniu spodnej konštrukcie alebo podlahy. Zvážte správne výškové nastavenie oporných nôh po usadení postele do konečnej polohy. Pred premiestnením na nové miesto postel' rozoberte.

SI POMEMBNO!- Posteljo po končni montaži premaknite izključno z dvignjenimi podpornimi nogami, da se izognete poškodbam na podkonstrukciji ali tleh. Razmislite o pravilni nastavitvi višine podpornih nog po namestitvi postelje v končni položaj. Razstavite posteljo, preden se preselite na novo lokacijo.

HR VAŽNO!- Premjestite krevet nakon konačnog sastavljanja isključivo s podignutim potpornim nogama, kako biste izbjegli oštećenja na potkonstrukciji ili podu. Razmislite o ispravnom namještanju visine potpornih nogu nakon postavljanja kreveta u konačni položaj. Rastavite krevet prije premještanja na novo mjesto.

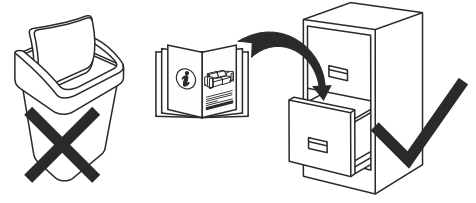

IT IMPORTANTE!- Riposizionare il letto dopo il montaggio finale esclusivamente con le gambe di supporto sollevate, al fine di evitare danni alla sottostruttura o al pavimento. Considerare la corretta regolazione dell'altezza delle gambe di supporto dopo aver sistemato il letto nella posizione finale. Smontare il letto prima di spostarlo in una nuova posizione.

ES IMPORTANTE!- Reubique la cama después del montaje final únicamente con patas de apoyo levantadas, para evitar daños en la subestructura o el piso. Considere el ajuste correcto de la altura de las patas de apoyo y luego coloque la cama en la posición final. Desmonte la cama antes de trasladarla a una nueva ubicación.

BA VAŽNO!- Premjestite krevet nakon konačnog sastavljanja isključivo s podignutim pomoćnim nogama, kako bi se izbjegla oštećenja na potkonstrukciji ili podu. Razmislite o ispravnom podešavanju visine pomoćnih nogu nakon postavljanja kreveta u konačni položaj. Rastavite krevet prije nego što se preselite na novu lokaciju.

RS VAŽNO!- Premjestite krevet nakon konačnog sastavljanja isključivo s podignutim pomoćnim nogama, kako bi se izbjegla oštećenja na potkonstrukciji ili podu. Razmislite o ispravnom podešavanju visine pomoćnih nogu nakon postavljanja kreveta u konačni položaj. Rastavite krevet prije nego što se preselite na novu lokaciju.

UA УВАГА!- Переміщайте ліжко після остаточного складання виключно з піднятими опорними ніжками, щоб уникнути пошкоджень на підконструкції або підлозі. Подумайте про правильне регулювання висоти опорних ніжок після встановлення ліжка в кінцеве положення. Розберіть ліжко перед тим, як переїхати на нове місце.

RO IMPORTANT!- Mutați patul după asamblarea finală numai cu picioare de sprijin ridicate, pentru a evita deteriorarea substructurii sau a pardoselii. Luați în considerare reglarea corectă a înălțimii picioarelor de sprijin după așezarea patului în poziția finală. Dezasamblați patul înainte de a vă muta într-o locație nouă.

BG ВАЖНО!- Преместете леглото след окончателното сглобяване единствено с повдигнати опорни крака, за да избегнете повреди по основата или подовата настилка. Помислете за правилно регулиране на височината на опорните крака, след като поставите леглото в крайна позиция. Разглобете леглото, преди да се преместите на ново място.

GR ΣΗΜΑΝΤΙΚΟ!- Επανατοποθετήστε το κρεβάτι μετά την τελική συναρμολόγηση αποκλειστικά με ανυψωμένα πόδια στήριξης, προκειμένου να αποφευχθούν ζημιές στην υποδομή ή το δάπεδο. Εξετάστε τη σωστή ρύθμιση ύψους των ποδιών στήριξης μετά την τοποθέτηση του κρεβατιού στην τελική θέση. Αποσυναρμολογήστε το κρεβάτι πριν μετακινηθείτε σε νέα θέση.

PT AVISO IMPORTANTE!- Reposicione a cama após a montagem final apenas com as pernas de apoio levantadas, a fim de evitar danos na subestrutura ou no piso. Considere o ajuste correto da altura das pernas de apoio depois de colocar a cama na posição final. Desmonte a cama antes de se mudar para um novo local.

RU ВАЖНО!- Перемещайте кровать после окончательной сборки только с поднятыми опорными ножками, чтобы избежать повреждений на основании или напольном покрытии. Продумайте правильную регулировку высоты опорных ножек после того, как уложите кровать в окончательное положение. Разберите кровать перед переездом на новое место.

TR ÖNEMLİ!- Son montajdan sonra, alt yapıda veya zeminde hasar görmemesi için yatağın yerini yalnızca yükseltilmiş destek ayakları ile değiştirin. Yatağı son konuma yerleştirdikten sonra destek ayaklarının doğru yükseklik ayarını düşünün. Yeni bir yere taşınmadan önce yatağı sökün.

مهم! AR

قم بنقل السرير بعد التجميع النهائي فقط بأرجل الدعم المرفوعة ، لتجنب الأضرار التي تلحق بالهيكل السفلي أو الأرضيات.
ضع في اعتبارك التعديل الصحيح للارتفاع لأرجل الدعم بعد ذلك ، وتسوية السرير في الموضع النهائي.
قم بتفكيك السرير قبل الانتقال إلى مكان جديد.

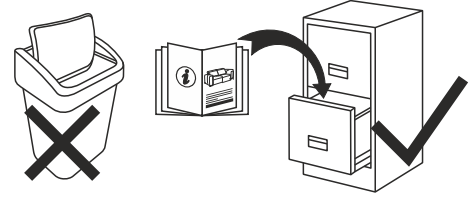

GB IMPORTANT!- Chocking hazard. Small parts present in unassembled state.
Keep away from children and pets.

DE WICHTIG!- Gefahr des Erstickens. Kleinteile liegen in unmontiertem Zustand vor.
Von Kindern und Haustieren fernhalten.

FR IMPORTANT!- Risque de choc. Petites pièces présentes à l'état non assemblé.
Tenir hors de portée des enfants et des animaux domestiques.

PL WAŻNE!- Niebezpieczeństwo zadławienia. Małe części obecne w stanie niezmontowanym.
Przechowywać z dala od dzieci i zwierząt.

DK VIGTIGT!- Fare for at komme i gang. Små dele til stede i usamlet tilstand. Holdes væk fra børn og kæledyr.

NO VIKTIG!- Chocking fare. Små delar til stades i umontert tilstand. Halda unna barn og kjæledyr.

SE VIKTIGT!- Risk för stoppkloss. Små delar som finns i omonterat tillstånd.
Förvaras åtskilt från barn och husdjur.

FI TÄRKEÄÄ!- Tukehtumisvaara. Pienet osat ovat kokoamattomassa tilassa.
Pidä poissa lasten ja lemmikkien ulottuvilta.

CZ DŮLEŽITÉ!- Nebezpečí udušení. Malé díly přítomné v nasmontovaném stavu.
Uchovávejte mimo dosah dětí a domácích zvířat.

HU FONTOS!- Fulladásveszély. Kis alkatrészek összeszereletlen állapotban.
Gyermekektől és háziállatoktól távol tartandó.

NL BELANGRIJK!- Verstikkingsgevaar. Kleine onderdelen aanwezig in niet-gemonteerde staat.
Buiten bereik van kinderen en huisdieren houden.

SK DÔLEŽITÉ!- Nebezpečenstvo udusenja. Malé časti prítomné v nezmontovanom stave.
Uchovávať mimo dosahu detí a domácich zvierat.

SI POMEMBNO!- Nevarnost zadušitve. Majhni deli so prisotni v nesestavljenem stanju.
Hranite stran od otrok in hišnih ljubljencev.

HR VAŽNO!- Opasnost od gušenja. Mali dijelovi prisutni u nesastavljenom stanju.
Držite podalje od djece i kućnih ljubimaca.

IT IMPORTANTE!- Pericolo di soffocamento. Piccole parti presenti allo stato non assemblato.
Tenere lontano dalla portata di bambini e animali domestici.

ES IMPORTANTE!- Peligro de asfixia. Piezas pequeñas presentes en estado desmontado.
Mantener alejado de los niños y las mascotas.

BA VAŽNO!- Opasnost od gušenja. Mali dijelovi prisutni u nesastavljenom stanju.
Držite podalje od djece i kućnih ljubimaca.

RS VAŽNO!- Opasnost od gušenja. Mali dijelovi prisutni u nesastavljenom stanju.
Držite podalje od djece i kućnih ljubimaca.

UA УВАГА!- Небезпека удушення. Дрібні деталі присутні в розібраному стані.
Зберігати в недоступному для дітей та домашніх тварин місці.

RO IMPORTANT!- Pericol de sufocare. Piese mici prezente în stare neasamblată.
A se păstra departe de copii și animale de companie.

BG ВАЖНО!- Опасност от задушаване. Малки части, присъстващи в неразглобено състояние.
Пазете от деца и домашни любимци.

GR ΣΗΜΑΝΤΙΚΟ!- Κίνδυνος πνιγμού. Μικρά μέρη που υπάρχουν σε μη συναρμολογημένη κατάσταση.
Κρατήστε μακριά από παιδιά και κατοικίδια ζώα.

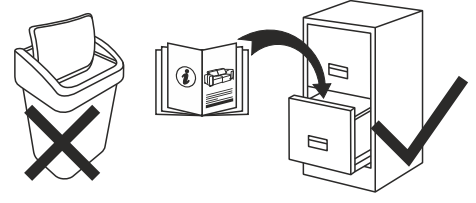

PT AVISO IMPORTANTE!- Perigo de asfixia. Pequenas peças presentes no estado desmontado. Mantenha longe de crianças e animais de estimação.

RU ВАЖНО!- Опасность удушья. Мелкие детали присутствуют в разобранном состоянии. Держите подальше от детей и домашних животных.

TR ÖNEMLİ!- OBoğulma tehlikesi. Monte edilmemiş durumda bulunan küçük parçalar. Çocuklardan ve evcil hayvanlardan uzak tutun.

مهم! AR

. يحفظ بعيدا عن متناول الأطفال الأليفة. الأجزاء الصغيرة موجودة في حالة غير مجمعة. خطر الاختناق

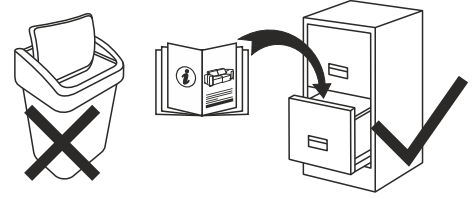

GB IMPORTANT! - The product is intended for domestic use. After assembling this product, it is advisable to ventilate the room regularly for a few days. Risk of being pinched when closing the storage box.

DE WICHTIG! - Das Produkt ist für den Heimgebrauch bestimmt. Nach der Montage des Produkts empfiehlt es sich, den Raum mehrere Tage lang regelmäßig zu lüften. Gefahr, beim Schließen der Aufbewahrungsbox eingeklemmt zu werden.

FR IMPORTANT - Le produit destiné à un usage domestique. Après assemblage de ce produit, il est conseillé d'aérer régulièrement la pièce pendant. Risque de pincement lors de la fermeture du coffre de rangement.

PL WAŻNE! - Produkt przeznaczony do użytku domowego. Po złożeniu produktu wskazane jest regularne wentrowanie pomieszczenia przez kilka dni. Ryzyko uszczyplnienia przy zamykaniu pojemnika na pościel.

DK VIGTIGT! - Produktet er beregnet til husholdningsbrug. Efter montering af dette produkt anbefales det at ventilere rummet regelmæssigt i et par dage. Risiko for at blive klemt, når opbevaringsboksen lukkes.

NO VIKTIG! - Produktet er beregnet for husholdningsbruk. Etter å ha satt sammen dette produktet, er det tilrådelig å ventilere rommet regelmessig i noen dager. Risiko for å bli klemt ved lukking av oppbevaringsboksen.

SE VIKTIGT! - Produktet er beregnet for husholdningsbruk. Etter å ha satt sammen dette produktet, er det tilrådelig å ventilere rommet regelmessig i noen dager. Risk att klämmas vid stängning av förvaringsboxen.

FI TÄRKEÄÄ! - Produktet er beregnet for husholdningsbruk. Etter å ha satt sammen dette produktet, er det tilrådelig å ventilere rommet regelmessig i noen dager. Riski puristaa säilytyslaatikkoa suljettaessa.

CZ DŮLEŽITÉ! - Výrobek je určen pro domácí použití. Po sestavení tohoto produktu je vhodné místnost pravidelně větrat po dobu několika dní. Riziko sevření při zavírání úložného boxu.

HU FONTOS! - A terméket háztartási használatra szánják. A termék összeszerelése után célszerű néhány napig rendszeresen szellőztetni a helyiséget. A tárolódoboz bezárásakor becsípődés veszélye.

NL BELANGRIJK! - Het product is bedoeld voor huishoudelijk gebruik. Na het monteren van dit product is het raadzaam om de kamer een paar dagen regelmatig te ventileren. Risico om geknepen te worden bij het sluiten van de opbergdoos.

SK DÔLEŽITÉ! - Výrobok je určený na domáce použitie. Po zostavení tohto produktu je vhodné miestnosť pravidelne vetrať niekoľko dní. Riziko zovretia pri zatváraní úložného boxu.

SI POMEMBNO! - Izdelek je namenjen domači uporabi. Po sestavljanju tega izdelka je priporočljivo redno prezračevati prostor za nekaj dni. Tveganje, da vas stisnejo pri zapiranju škatle za shranjevanje.

HR VAŽNO! - Proizvod je namijenjen za kućnu upotrebu. Nakon sastavljanja ovog proizvoda, preporučljivo je redovito prozračiti sobu nekoliko dana. Rizik od ukleštenja prilikom zatvaranja kutije za pohranu.

IT IMPORTANTE! - Prodotto destinato all'uso domestico. Dopo aver assemblato il prodotto, è consigliabile aerare regolarmente la stanza per diversi giorni. Rischio di essere pizzicato quando si chiude la scatola di stoccaggio.

ES IMPORTANTE - El producto está destinado a uso doméstico. Después de montar este producto, es recomendable ventilar la habitación periódicamente durante unos días. Riesgo de quedar atrapado al cerrar la caja de almacenamiento.

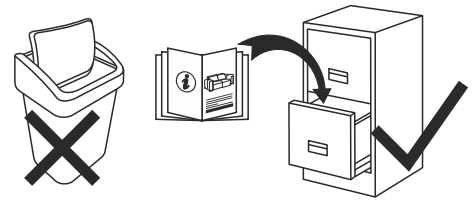

BA VAŽNO! - Proizvod je namijenjen za domaću upotrebu. Nakon sklapanja ovog proizvoda, preporučljivo je redovno ventilirati prostoriju na nekoliko dana. Rizik da budete uklješteni prilikom zatvaranja kutije za skladištenje.

RS VAŽNO! - Proizvod je namijenjen za kućnu upotrebu. Nakon sastavljanja ovog proizvoda, preporučljivo je redovno prozračiti sobu nekoliko dana. Rizik od stezaња prilikom zatvaranja kutije za skladištenje.

UA УВАГА. - Продукт призначений для побутового використання. Після складання цього виробу бажано регулярно провітрювати приміщення протягом декількох днів. Ризик бути затиснутим при закритті ящика для зберігання.

RO IMPORTANT! - Produsul este destinat uzului casnic. După asamblarea acestui produs, este recomandabil să ventilați camera în mod regulat timp de câteva zile. Risc de a fi ciupit la închiderea cutiei de depozitare.

BG ВАЖНО! - Продуктът е предназначен за домашна употреба. След сглобяването на този продукт е препоръчително стаята да се проветрява редовно в продължение на няколко дни. Риск от прищипване при затваряне на кутията за съхранение.

GR ΣΗΜΑΝΤΙΚΟ! - Το προϊόν προορίζεται για οικιακή χρήση. Μετά τη συναρμολόγηση αυτού του προϊόντος, συνιστάται να αερίζετε τακτικά το δωμάτιο για μερικές ημέρες. Κίνδυνος τσιμπήματος κατά το κλείσιμο του κουτιού αποθήκευσης.

PT AVISO IMPORTANTE! - O produto destina-se a uso doméstico. Após a montagem deste produto, é aconselhável ventilar a sala regularmente por alguns dias. Risco de ser beliscado ao fechar a caixa de armazenamento.

RU ВАЖНО! - Средство предназначено для бытового использования. После сборки этого изделия желательно в течение нескольких дней регулярно проветривать помещение. Риск быть зажатым при закрытии ящика для хранения.

TR ÖNEMLİ! - Ürün evde kullanım için tasarlanmıştır. Bu ürünü monte ettikten sonra, odayı birkaç gün boyunca düzenli olarak havalandırmanız tavsiye edilir. Saklama kutusunu kapatırken sıkıştırılma riski.

مهم! AR

المنتج مخصص للاستخدام المنزلي. بعد تجميع هذا المنتج، يُنصح بتهوية الغرفة بانتظام لبضعة أيام. خطر التعرض للقرص عند إغلاق المخزن

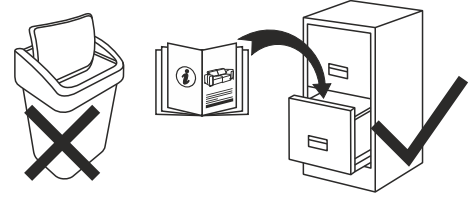

GB IMPORTANT! - It is important that any product which is assembled using any kind of screw is re-tightened 2 weeks after assembly, and once every 3 months - in order to assure stability through-out the lifespan of the product.

DE WICHTIG! - Es ist wichtig, bei jedem mit Schrauben montierten Produkt diese 2 Wochen nach dem Zusammenbau sowie einmal alle 3 Monate wieder anzuziehen, um die Stabilität des Produkts über die gesamte Lebensdauer hinweg zu gewährleisten.

FR IMPORTANT - Il est important que tout produit monté à l'aide de vis soit resserré 2 semaines après son montage, puis tous les 3 mois, afin de garantir sa stabilité durant tout son cycle de vie.

PL WAŻNE! - Ważne jest, żeby każdy ze skręcanych produktów został ponownie dokręcony w ciągu 2 tygodni od montażu, a następnie sprawdzać co 3 miesiące czy śruby są dokręcone — w celu zapewnienia stabilności przez czas użytkowania produktu.

DK VIGTIGT! - Det er vigtigt, at alle produkter, der samles med alle former for skruer, efterspændes to uger efter samling samt hver tredje måned for at sikre, at produktet er stabilt i hele dets levetid.

NO VIKTIG! - Det er viktig at alle produkter som monteres med skruer blir etterstrammet 2 uker etter montering, og hver 3. måned for å sikre stabiliteten gjennom hele produktets levetid

SE VIKTIGT! - För alla produkter som monteras med skruv är det viktigt att dessa efterdras två veckor efter monteringen och därefter en gång var tredje månad. Detta för att säkerställa att produkten håller sig stabil under hela sin livslängd.

FI TÄRKEÄÄ! - On tärkeää, että kaikki ruuvien avulla koottavat tuotteet kiristetään uudelleen 2 viikkoa kokoamisen jälkeen ja aina 3 kuukauden välein, jotta tuote pysyy vakaana koko käyttöikänsä ajan.

CZ DŮLEŽITÉ! - U každého výrobku, který se sestavuje pomocí jakýchkoli šroubků, je důležité dotáhnout šroubky 2 týdny po sestavení a potom každé 3 měsíce, aby byla zajištěna stabilita po celou dobu životnosti výrobku.

HU FONTOS! - Minden terméknél fontos, hogy bármilyen fajta csavarral is történi az összeszerelése, utána 2 héttel, majd 3 havi rendszerességgel szükséges a csavarok utánhúzása. Ezzel a termék teljes élettartamán keresztül biztosítható a stabilitása.

NL BELANGRIJK! - Het is belangrijk om elk product dat met om het even welk soort schroef wordt gemonteerd, twee weken na montage en om de drie maanden, opnieuw wordt vastgeschroefd, om de stabiliteit van het product tijdens de hele levensduur te verzekeren.

SK DÔLEŽITÉ! - Je dôležité, aby sa na akomkoľvek produkte, montovanom pomocou akýchkoľvek skrutiek, skrutky dotiahli po dvoch týždňoch od montáže, a jedenkrát v priebehu každých 3 mesiacov – tak sa zaručí stabilita počas celej životnosti produktu.

SI POMEMBNO! - Vsak izdelek, ki ga sestavite z uporabo kakršnihkoli vijakov morate 2 tedna po sestavitvi ponovno pregledati in vijake po potrebi priviti. To ponovite vsake 3 mesece, da bi zagotovili stabilnost izdelka skozi njegovo celotno življenjsko dobo.

HR VAŽNO! - Važno je da se svi tipovi vijaka na bilo kojoj vrsti proizvoda koji se s pomoću njih sastavlja ponovno pritegnu 2 tjedna nakon sastavljanja te jednom svaka 3 mjeseca - kako bi se zajamčila stabilnost tijekom životnog vijeka proizvoda.

IT IMPORTANTE! - È importante in ogni prodotto montato con viti serrare ben strette le viti 2 settimane dopo il montaggio e poi ogni 3 mesi per garantire la sua stabilità durante tutta la durata del prodotto.

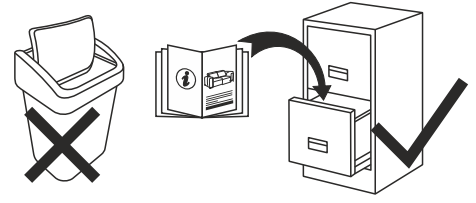

ES IMPORTANTE - En el caso de los productos ensamblados, es importante volver a apretar los tornillos 2 semanas después del montaje y después cada 3 meses, para así preservar la estabilidad durante toda la vida útil del producto.

BA VAŽNO! - Za sve proizvode sa vijčanim vezama, potrebno je izvršiti pritezanje 2 sedmice nakon sklapanja i svaka 3 mjeseca nakon toga, kako bi se osigurala stabilnost tokom cijelog životnog vijeka proizvoda.

RS VAŽNO! - Važno je da svaki proizvod koji je sklopljen korišćenjem bilo kakvih šrafova bude ponovo pričvršćen 2 nedelje nakon sklapanja i jednom svaka 3 meseca - kako bi se obezbedila stabilnost tokom celog veka trajanja proizvoda.

UA УВАГА. - Майте на увазі, якщо у процесі монтажу продукту використовуються гвинти будь-якого типу, їх треба повторно затягнути через 2 тижні після монтажу, а потім кожні 3 місяці. Це необхідно для того, щоб забезпечити надійне використання продукту протягом терміну його служби.

RO IMPORTANT! - Este important ca șuruburile de orice tip, cu ajutorul cărora au fost montate produsele, să fie strânse din nou la 2 săptămâni după montare și, apoi, o dată la 3 luni, pentru a se asigura stabilitatea de-a lungul duratei de viață a produsului

BG ВАЖНО! - Важно е всеки продукт, който е сглобен с помощта на винтове, да бъде затегнат 2 седмици след сглобяването, и веднъж на всеки 3 месеца, за да се гарантира стабилност през цялото време на използване на продукта.

GR ΣΗΜΑΝΤΙΚΟ! - Για κάθε προϊόν που συναρμολογείται με βίδες είναι σημαντικό αυτές να ξανασφίγγονται 2 εβδομάδες μετά τη συναρμολόγηση και μία φορά κάθε 3 μήνες, για τη διασφάλιση της σταθερότητας σε όλη τη διάρκεια ζωής του προϊόντος.

PT AVISO IMPORTANTE! - É importante, em cada produto montado com parafusos, reapertar os mesmos 2 semanas após a montagem e uma vez a cada 3 meses para garantir a estabilidade do produto ao longo de toda a sua vida útil.

RU ВАЖНО! - В любом изделии, собранном с использованием винтов любого типа, необходимо через 2 недели после сборки и в дальнейшем каждые 3 месяца подтягивать винты, чтобы обеспечить прочность изделия в течение срока эксплуатации.

TR ÖNEMLİ! - Vida kullanılarak yapılan her türlü ürün montajı için montajdan 2 hafta sonra vidaların yeniden sıkıştırılması ve kullanım süresi boyunca ürün istikrarının sağlanması için de her 3 ayda bir vidaların sıkıştırılması önem arz eder.

مهم! AR

من المهم أن يتم إعادة ربط أي منتج يتم تجميعه باستخدام أي نوع من البراغي بعد أسبوعين من التجميع، ومرة واحدة كل 3 أشهر - من أجل ضمان الاستقرار طوال عمر المنتج.

